

HEATCRAFT

STEAM COIL

INSTALLATION OPERATION AND MAINTENANCE



Commercial Products

PO Box 1457 / 1000 Heatcraft Drive, Grenada, MS 38902-1457

Tel: 800-225-4328 / 662-229-4000 Fax: 662-229-4212

Email: coils@heatcraft.com

Web Site: www.heatcraft.com

Guidelines for the installation, operation and maintenance of Heatcraft’s steam heating coils have been provided to help insure the proper performance of the coils and their longevity. These are general guidelines, which may have to be tailored to meet the specific requirements of any one job. As always, a qualified party or individual should perform the installation and maintenance of any coil. Protective equipment such as safety glasses, steel toe boots and gloves are recommended during the installation and routine maintenance of the coil. **Caution! Steam, even at low pressure, can cause serious bodily injury that may result in death. Be sure the system is off or the components are isolated before beginning work.**

Receiving Instructions

1. All Heatcraft coils are factory tested, inspected and carefully packaged.
2. Damage to the coils can occur after they have left the factory. Therefore, the coils should be inspected for shipping damage upon receipt. The freight bill should also be checked against items received for complete delivery.
3. Damaged and/or missing items should be noted on the carrier’s freight bill and signed by the driver.
4. For additional assistance, contact your local Heatcraft representative.

Nomenclature

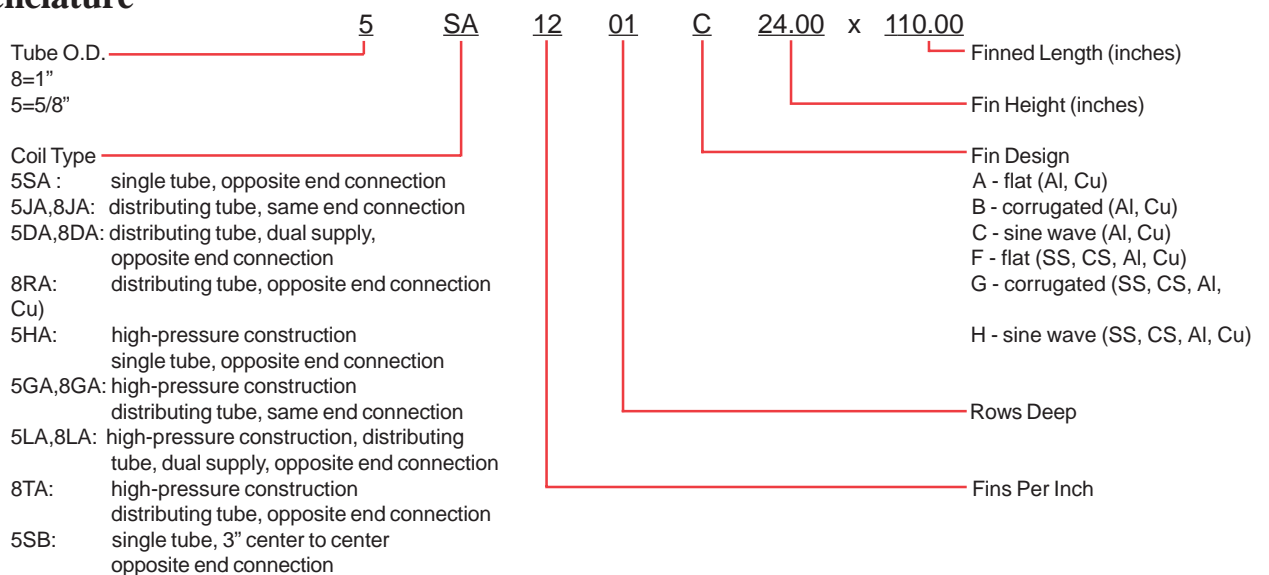

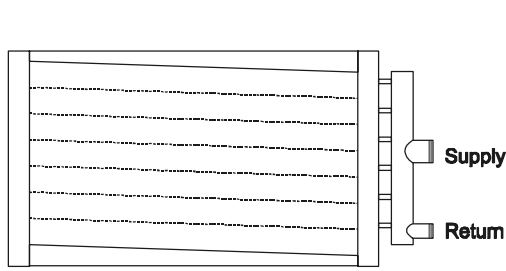

Figure1a - Case Pitched

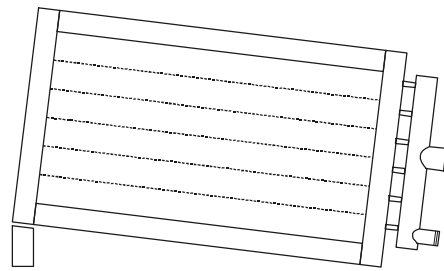

Figure1b - Case Unpitched

Mounting

Steam coils must be properly mounted for condensate removal. This will aid in preventing destructive water-hammer, keeping coils from freezing and preventing corrosive elements from collecting in the tubes. Case-pitched coils should be installed level as shown in Figure 1a. Heatcraft models SA, SB, HA, JA, GA, DA, LA, RA and TA come standard pitched in the casing. Heatcraft models SS and SH utilize return bend construction and are not pitched in the casing, but need to be installed level as in Figure 1a - Case Pitched. Coils that are unpitched, must be installed with the tubes pitched towards the return connection as shown in Figure 1b (with the exception of Heatcraft models SS and SH). A minimum pitch of 1/8" per foot of coil length is required (pitch has been exaggerated in Figure 1b - Case Unpitched).

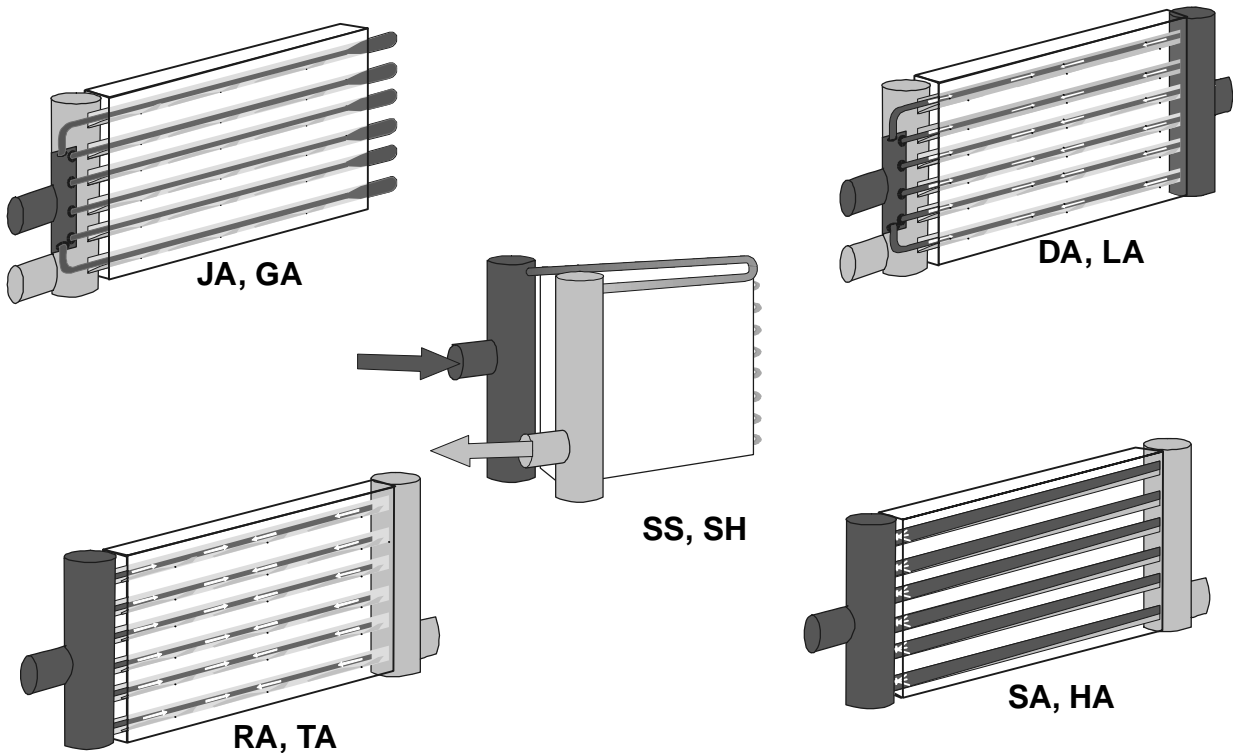

Figure 2 - Coil Types

Coil Types

Distributing

Heatcraft’s JA, RA and DA jet-tube steam distributing coils are excellent for any general purpose heating application. With the superior freeze resistance provided by the tube-within-a-tube construction, it is ideal for low temperature preheating and special process applications. The construction features inner tubes with directional orifices to aid in steam distribution and condensate removal. Model JA offers same-end supply and return connections. Model RA offers opposite-end supply and return connections. Model DA offers dual-supply opposite-end connections for long coils that see sub-freezing air temperatures. Models GA, TA and LA utilize cupro-nickle, carbon steel and stainless steel tubing for high-pressure construction.

Single Tube

Heatcraft’s SA steam coil is designed for general purpose heating. The construction features a single tube design with opposite-end supply and return connections. A perforated baffle located directly behind the supply connection insures proper steam distribution. Model HA utilizes cupro-nickle, carbon steel and stainless steel tubing for high-pressure construction.

Standard Steam

Heatcraft’s SS steam coil features return-bend construction and same-end connections. Model SH utilizes cupro-nickle, carbon steel and stainless steel tubing for high-pressure construction.

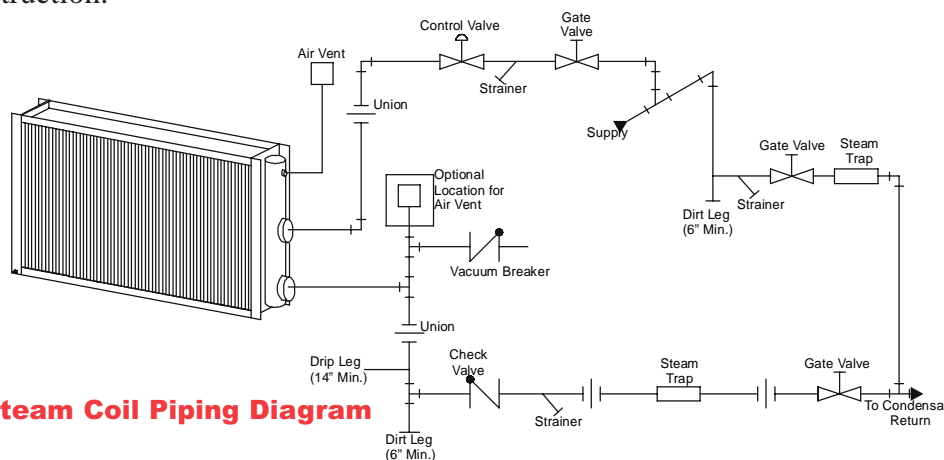

Figure 3 - Steam Coil Piping Diagram

Note 1: Vacuum breakers and air vents should be piped to a drain or other suitable location where discharged steam cannot lead to personal injury.

Installation

1. Carefully remove the coil from the shipping package to avoid damage to the finned surface area. Damaged fins can be straightened using an appropriate fin comb.
2. Heatcraft recommends cleaning the coil with a commercially available coil cleaner prior to installation. Refer to **Maintenance** on Page 5 for cleaning recommendations.

3. Mount coil properly to insure positive condensate drainage. Refer to *Mounting* instructions Page 2.
4. Proper clearance should be maintained between the coil and other structures such as the fan, filter racks, transition areas, etc.
5. Utilize vacuum breakers on each coil. Steam traps require a positive pressure differential to force the condensate through the valve seat. If the coil's pressure drops below atmospheric, the pressure differential across the valve will be negative and the condensate will not drain. This condition can lead to serious damage or failure of the coil due to freezing, water hammer and corrosion. Refer to piping diagram for recommended placement. See Note 1 in Figure 3 - Steam Coil Piping Diagram on Page 3.
6. Trap each coil separately. Differences in pressure from coil to coil can result in the backing-up of condensate which will result in poor coil performance and possible damage.
7. Provide an air vent for each coil at its highest location. Heatcraft provides a ½" threaded vent connection on the return manifold as a standard on all steam coils. Non-condensable gasses present in the steam will collect in a coil and reduce its capacity. Therefore, it is necessary to provide a means for the removal of these gasses. Also, these gasses can diffuse into the condensate forming byproducts, which can lead to severe corrosion. See Note 1 in Figure 3 - Steam Coil Piping Diagram on Page 3.
8. Steam supply lines need to be drained of condensate. This can be accomplished by the use of drip legs. This ensures that high quality steam enters the coil.
9. Condensate return piping should be the same size as the coil's return connection from the coil outlet to the steam trap.
10. Once installed, the coil should be pressurized to 100 psig with dry nitrogen or other suitable gas. The coil should be left pressurized for a minimum of 10 minutes. If the coil holds the pressure, the hook-up can be considered leak free. If the pressure drops by 5 psig or less, re-pressurize the coil and wait another 10 minutes. If the pressure drops again, there are more than likely one or more small leaks, which should be located and repaired. Pressure losses greater than 5 psig would indicate a larger leak, which should be isolated and repaired. Be sure to check valves and fittings as potential sites for leakage or bleed. If the coil itself is found to be leaking, contact your local Heatcraft representative. Unauthorized repair to the coil may void the coil's warranty (see Heatcraft's warranty policy on back cover).
11. All field brazing and welding should be performed using high quality materials and an inert gas purge (such as nitrogen) to reduce oxidation of the internal surface of the coil.
12. All field piping must be self supporting. System piping should be flexible enough to allow for thermal expansion and contraction of the coil. The use of flexible connections and/or swing joints is recommended.

13. The coil along with the control valve and trap should be isolated by manual valves to allow for servicing.
14. Refer to Figure 3 - Steam Coil Piping Diagram on Page 3 for general piping.
15. If you are unsure about any portion of the installation, contact your local steam specialist for assistance. Failure to properly install the coil can result in irreparable damage to the coil as well as other components in the system.

Operation

1. Proper air distribution is vital to coil performance. Air-flow anywhere on the coil face should not vary by more than 20%.
2. Air velocities should be maintained between 200 and 1500 feet per minute.
3. Operating pressures must be at or below the maximum operating pressure for that coil at the steam temperature. Pressure and temperature limitations can be determined through Heatcraft's *Pressure and Temperature* program. Contact your local Heatcraft representative for assistance.

Maintenance

1. Scheduled plant maintenance should include the draining and flushing of the condensate drip legs and sediment traps as well as inspection of condensate traps, vacuum breakers, air vents and valves. Boiler water analysis should also be performed on a regular basis.
2. To continually deliver full heating capacity, both the external and internal heat transfer surfaces must be maintained as clean and corrosion free as possible. The finned surface can be maintained by the use and constant inspection of pre-filters. The filters should be replaced as needed.
3. Should the finned surface become fouled, the coil can be cleaned utilizing commercially available coil cleaning fluids. Caution should be exercised in selecting the cleaning solution as well as the cleaning equipment. Improper selection can result in damage to the coil and/or health hazards. Be sure to carefully read and follow the manufacturer's recommendations before using any cleaning fluid. Clean the coil from the leaving air-side so that foreign material will be washed out of the coil rather than pushed further in.
4. Internal coil maintenance consists primarily of preventing scale and corrosion. This is accomplished through aggressive boiler water treatment, removal of dissolved oxygen and the removal of non-condensable gasses such as carbon dioxide.

Note: Boiler water treatment is beyond the scope of this manual. Contact your local water treatment specialist for assistance in establishing a proper boiler-water treatment program.

HEATCRAFT

Commercial Products

WARRANTY

The Heat Transfer Division of Heatcraft Inc., hereinafter referred to as the "Company", warrants that it will provide free suitable repair or replacement of coils in the event any coil of its manufacture used in the United States proves defective in material or workmanship within twelve (12) months from the date shipped by the Company.

THIS WARRANTY CONSTITUTES THE BUYER'S SOLE REMEDY. IT IS GIVEN IN LIEU OF ALL OTHER WARRANTIES. THERE IS NO IMPLIED WARRANTY OF MERCHANT ABILITY OR FITNESS FOR A PARTICULAR PURPOSE. IN NO EVENT AND UNDER NO CIRCUMSTANCE SHALL THE COMPANY BE LIABLE FOR INCIDENTAL OR CONSEQUENTIAL DAMAGES, WHETHER THE THEORY BE BREACH OF THIS OR ANY OTHER WARRANTY, NEGLIGENCE, OR STRICT TORT.

This warranty extends only to the original purchaser. Of course, abuse, misuse, or alteration of the product in any manner voids the Company's warranty obligation.

This warranty does not obligate the Company to pay any labor or service costs for removing or replacing parts, or any shipping charges.

No person (including any agent or salesman) has authority to expand the Company's obligation beyond the terms of this express warranty, or to state that the performance of the coil is other than that published by the Heat Transfer Division of Heatcraft Inc.

December 1999

PO Box 1457 / 1000 Heatcraft Drive, Grenada, MS 38902-1457

Tel: 800-225-4328 / 662-229-4000 Fax: 662-229-4212

Email: coils@heatcraft.com

Web Site: www.heatcraft.com

Printed in U.S.A.