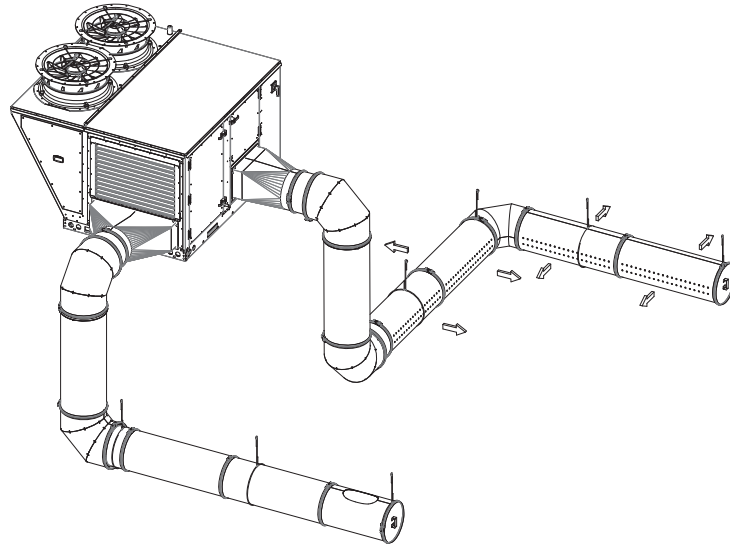


Supply Duct Systems

# Installation, Operation, and Maintenance Manual

---



### FOR YOUR SAFETY

**SUPPLY DUCT SYSTEMS MUST BE INSTALLED PER THIS INSTALLATION GUIDE. FAILURE TO DO SO COULD CAUSE CATASTROPHIC FAILURE. WHEN INSTALLING HVAC SYSTEMS THERE ARE MULTIPLE ASPECTS TO CONSIDER: ENVIRONMENTAL AND LOAD CONSIDERATIONS, HANGING CONFIGURATIONS, SIZE SELECTION, AND ATTACHMENT METHODS.**

### RECEIVING AND INSPECTION

**Examine All Components for Possible Shipping Damage before Installation. Different Manufacturers have Different Joint Systems and Adhesives. DO NOT Mix Pipe, Fittings, or Joining Methods from Different Manufacturers.**

### INSTALLATION

- Perforated supply duct sections should be installed entirely in exposed locations.
- Single wall supply duct blanks and double wall supply duct may be installed in enclosed locations.
- Supply duct systems should NOT pass through or penetrate fire-resistant rated construction unless protected by a listed firestop.

**Save these instructions. This document is the property of the owner of this equipment and is required for future maintenance. Leave this document with the owner when installation or service is complete.**



WARRANTY .....	4
APPLICATION .....	5
Selection Parameters .....	6
Selection Parameter Details .....	7
Supply Duct S0/High Capacity S0-HC - Corner Installation .....	8
Supply Duct S0/High Capacity S0-HC - Open Space Installation .....	10
Supply Duct S90/High Capacity S90-HC - Open Space Installation .....	12
Supply Duct S180/High Capacity S180-HC - Open Space Installation .....	14
INSTALLATION .....	16
Joint Gasket .....	16
Supply Duct Joint Assembly .....	17
Double Wall Supply Duct Joint Assembly .....	18
Single Wall Collar and Adjustable Duct Connections .....	19
Single Wall Collar and Adjustable Supply Duct Installation .....	20
Double Wall Adjustable Duct Connections .....	21
Double Wall Adjustable Duct Standard Installation .....	22
Single Wall Offset Distance .....	23
Double Wall Offset Distance .....	26
Single Wall Supply Duct Access Door Assembly .....	29
Double Wall Supply Duct Access Door Assembly .....	30
Supply Duct Noise Reducers .....	31
Main Benefits of Supply Duct Noise Reducers: .....	31
Single Wall Vertical Support Spacing and Wall Guide Support .....	33
Single Wall Vertical Wall Support (Wood, Concrete, Steel) .....	34
Single Wall Floor Support .....	37
Vertical Support & Vertical Support Spacing .....	39
Double Wall Support and Guide Plate .....	40
Double Wall Vertical Thimble Curb Assembly Installation .....	41
Horizontal Hanging Configurations .....	43
Horizontal Support and Support Spacing .....	44
Return Duct .....	46
DI-PSP, DI-Fuse, DI-Return and Connections .....	47
Perforated Plenums for Supply and Return Air .....	47
Connecting Drop-In Plenums .....	47
Installation Examples .....	48
Painting Ductwork .....	49
Curb and Adapter .....	50
Supply Duct Pad Mount Clearances .....	51
Supply Duct Assemblies .....	52
Pressure Testing per SMACNA's HVAC Air Duct Leakage .....	57
Test and Balance .....	57
Supply Duct Weights .....	58
Single Wall Supply Duct .....	58
24-Gauge Duct Weight (Diameters 5" – 24") .....	58
20-Gauge Duct Weight (Diameters 26" – 36") .....	58
Double Wall Supply Duct .....	58
DW-1S Duct Weight: .....	58
DW-2S Duct Weight: .....	58
DW-3S Duct Weight: .....	58
Double Wall Supply Duct Example Weight Calculations: .....	58
Cleaning & Maintenance Record .....	60

## **WARRANTY**

This ductwork system is warranted to be free from defects in material and workmanship, under normal use and service, for a period of 20-years from the date of shipment. This warranty shall not apply if:

1. The equipment is not installed by a qualified installer per this installation guide; this guide should be kept with the equipment once installation is complete.
2. The equipment is not installed in accordance with Federal, State, Local codes and regulations.
3. The equipment design or sizing is not approved per MANUFACTURER'S specifications.
4. The equipment is misused, neglected, or not maintained per the MANUFACTURER'S maintenance instructions.
5. The equipment is exposed to elevated temperatures due to a fire originating in the building, fan, or duct.
6. The equipment is not operated within its published capacity.
7. The equipment is operated, tested, or stored in the presence of chlorines, solvents, refrigerant vapors, caustic substances, halogenated compounds, or other conditions that could cause condensation of corrosive materials within or on the system.
8. The equipment is substituted or connected with parts not manufactured per Original Equipment Manufacturer.
9. The invoice is not paid within the terms of the sales agreement.

The MANUFACTURER shall not be liable for incidental and consequential losses and damages potentially attributable to malfunctioning equipment. Should any part of the equipment prove to be defective in material or workmanship within the 20-year warranty period, upon examination by the MANUFACTURER, such parts will be repaired or replaced by the MANUFACTURER at no charge. The BUYER shall pay all labor costs incurred in connection with such repair or replacement. Equipment shall not be returned without MANUFACTURER'S prior authorization, and all returned equipment shall be shipped by the BUYER, freight prepaid to a destination determined by the MANUFACTURER.

## APPLICATION

Air diffusion supply duct is designed to replace traditional HVAC supply duct systems using air vents, registers, and conventional diffusers. Compared to a majority of the diffusers offered on the market, air diffusion supply ducts are characterized as a high induction system. High induction systems are designed for superior mixing of air, resulting in high levels of thermal comfort in the space.

Each laser cut supply duct section has a specific hole pattern that has been designed for specific installation heights and applications. Unlike traditional vents, registers, and conventional diffusers, the input air is dispersed through a series of holes that allow precise control of air dispersement and throw. Air diffusion supply duct systems maximize performance when compared to traditional supply duct systems that can cause drafts in the space when not sized correctly. Air diffusion supply duct systems can be used in multiple applications such as warehouses, offices, theaters, and arenas or be used to retrofit older supply duct systems. Single wall supply duct should only be used in conditioned spaces within the building envelope.

Double wall supply duct is required for installations where the supply duct passes through unconditioned spaces. The International Conservation Code (IECC) provides a climate zone map that must be referenced when determining the recommended "R" value per zone. Refer to **Table 1** for manufacturer duct types and insulation R-value recommendations based on space types. Failure to select the correct double wall supply duct may result in water damage to the ceiling and wall surfaces. Extreme cases, mold may build up in the area or space.

**Table 1 - R-Value Recommendations**

<b>Supply Duct Type</b>	<b>Minimum R-Value</b>	<b>Space Type</b>
Single Wall - S & - HC	N/A	Conditioned Space Only
Double Wall - 1S	R-4	Unconditioned Interior Space Only
Double Wall - 2S	R-8	Unconditioned Space Climate Zone 1-4
Double Wall - 3S	R-12	Unconditioned Space Climate Zone 5-8

### Main benefits of supply duct:

- High induction mixing in rooms to quickly disperse supply air, and mix thoroughly in the conditioned space.
- Standard and high capacity supply duct systems can cover all applications.
- Drafts are avoided due to air diffusion along the entire length of the supply duct, so no additional vents and diffusers are required.
- Static pressure and airflow rates are highly defined, 3D-generated for exact performance.
- Stainless steel construction for installation aesthetics. It can be used in exposed installations for a modern look and feel.
- No field fabrication of individual duct pieces. All longitudinal seams are fully welded and leak tested.
- Quick on-site assembly with a bolt-together design. V-bands provide for secure sealed design.
- Easy installation of double wall sections, no field wrapping required.
- Double wall R-values are defined per **Table 1 on page 5**.
- Double wall insulation is protected by a stainless steel outer shell.
- Single and double wall supply duct uses the same joint connection, no additional tools required for double wall.
- Installation is made simple with a cable lock hanging system, see “**Horizontal Support and Support Spacing**” on page 44. This system can hang from most ceiling substrates.
- For return duct details, refer to “**Return Duct**” on page 46.

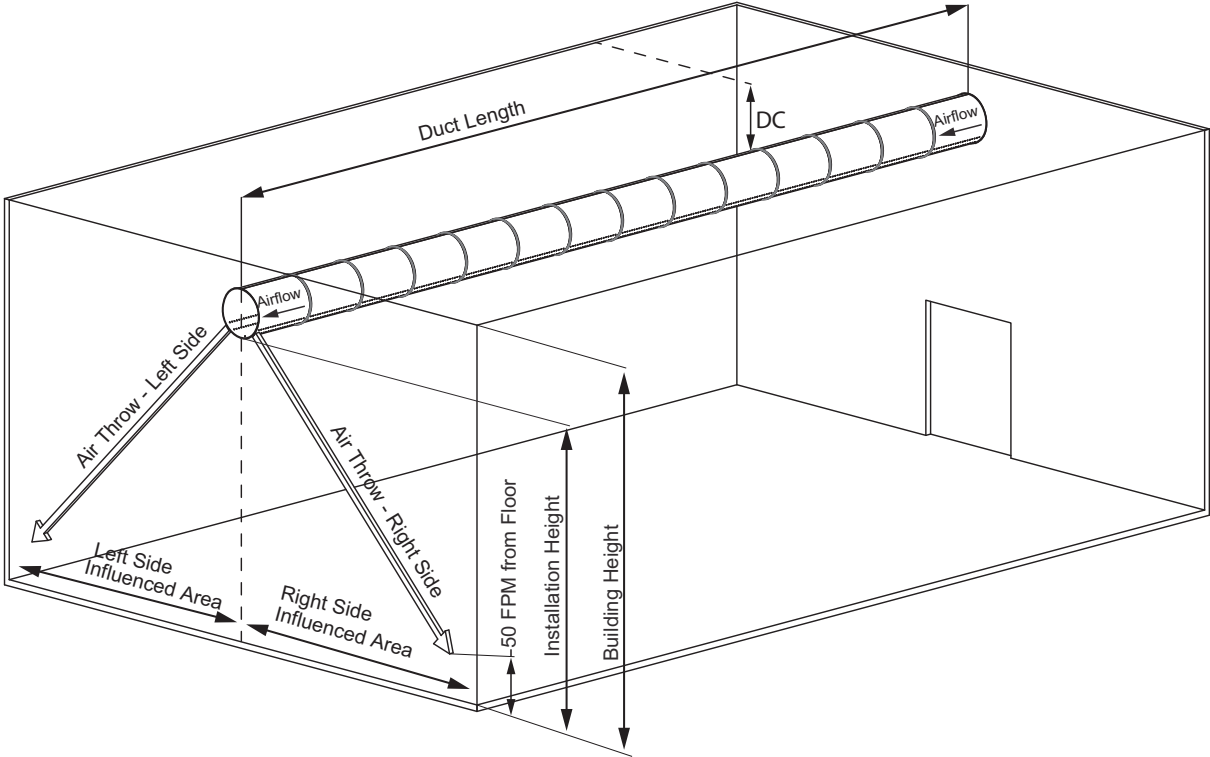
### Selection Parameters

Different than traditional HVAC supply duct systems that use vents and diffusers, air diffusion supply duct systems are engineered and manufactured for each project. Designs can be simple, straight systems, or very intricate layouts that incorporate fittings and transitions. Review the following list of guidelines before selecting the type of air diffusion supply duct needed for your specific application. **Figure 1 on page 7** provides basic visual installation details.

- **Air:** CFM requirements for your specific application, it is recommended to not exceed 1100 Feet Per Minute (FPM) at any point in the system.
- **Supply Type:** Standard supply duct is recommended for all applications. If the conditioned space is too small to fit the required number of standard supply duct sections, high capacity supply duct should be used. High capacity supply duct is available for applications that require larger amounts of CFM per foot.
- **Run Length & Layout:** Make sure the area of installation is free from anything that may block the path of the supply duct, such as piping, existing duct systems, sprinkler heads, and electrical conduits.
- **Duct Diameter (D):** Duct diameters should be sized as to not exceed the recommended maximum duct velocities at any point in the system.
- **Installation Height (H):** Installation height is taken from the bottom edge of the supply duct to the floor directly below.
- **Distance Between Duct & Ceiling (DC):** Distance between duct and ceiling is the distance between the top edge of the supply duct and the ceiling above. To prevent stratification, the maximum suggested distance from the ceiling to the top of the supply duct is  $DC = (H + D) * 0.15$ .
- **Influence Area:** Distance between the supply duct axis and the limit for the active influence of the air being diffused from the supply duct perforations.
- **Diffusion Angle (DA):** Diffusion angle inclination (DA) compared to the orthogonal supply duct axis. Generally, it is resulting from the relation between the influence area and the installation height and control area situated at which the throw velocity reaches 50 FPM from the floor. The customer can vary this parameter as needed by changing the angle of diffusion and the installation height of the supply duct.

**Selection Parameter Details**

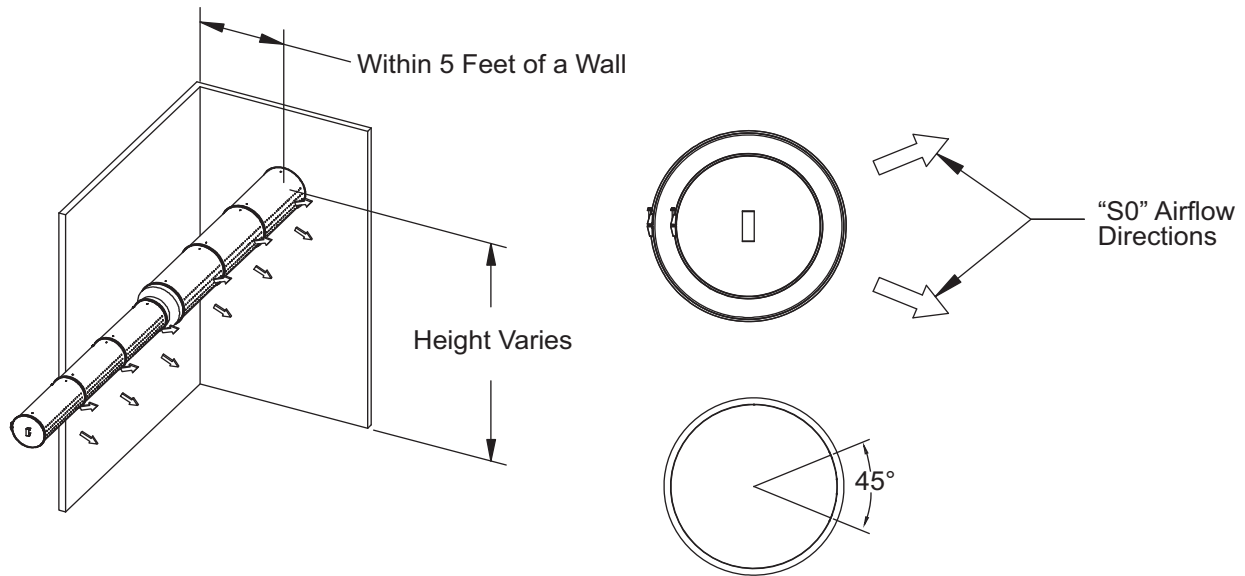
**Figure 1 - Parameter Details**



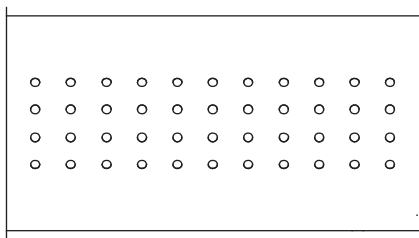
## Supply Duct S0/High Capacity S0-HC - Corner Installation

0 degree: For applications requiring corner installation, duct orientation can be changed as needed to direct air in specific directions. There are no height restrictions as the supply duct can be orientated to avoid drafts. Air will be diffused from one side of the supply duct into the space to avoid interference with adjacent walls. **Figure 2** shows Type S0 and S0-HC supply duct installed in a corner, such as an office space.

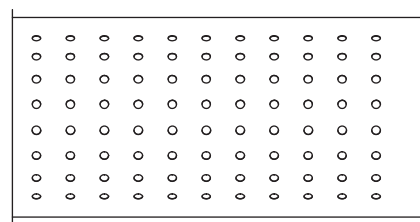
**Figure 2 - Type S0 & S0-HC Supply Duct Corner Installation**



**S0 Standard Supply Duct**



**S0-HC High Capacity Supply Duct**

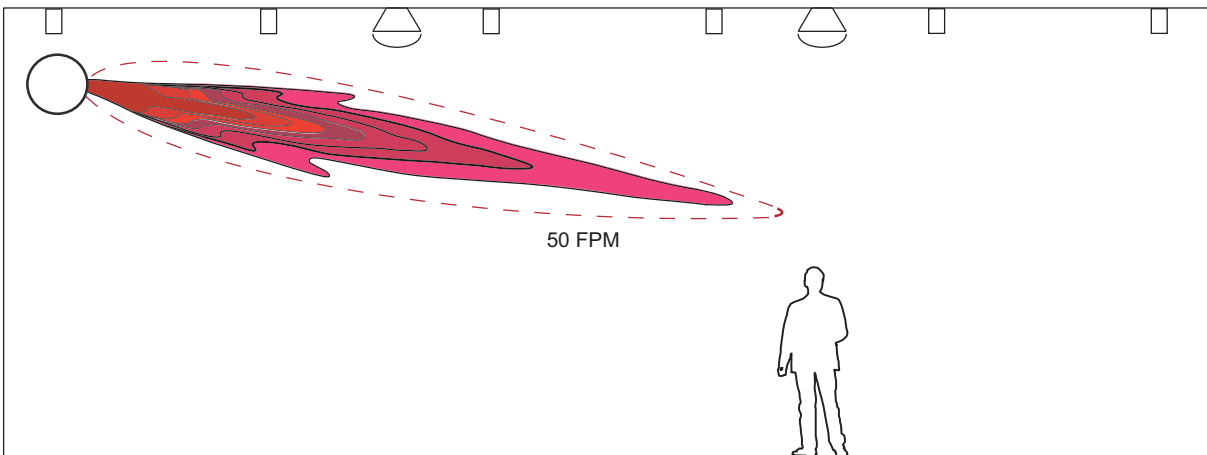




### Type S0 and S0-HC Corner Heating Situations

- Heating Computational Fluid Dynamics (CFD) Analysis (**Figure 3**) for S0 and S0-HC supply duct located in a corner. The CFD analysis is used to determine the diffusion of air leaving the supply duct and the distance of the throw velocity to 50 ft/min. Duct air temperature 80°F, room air temperature 70°F.
- No thermal stratification on heating applications, the heated air is quickly dispersed and mixed thoroughly in the conditioned space.

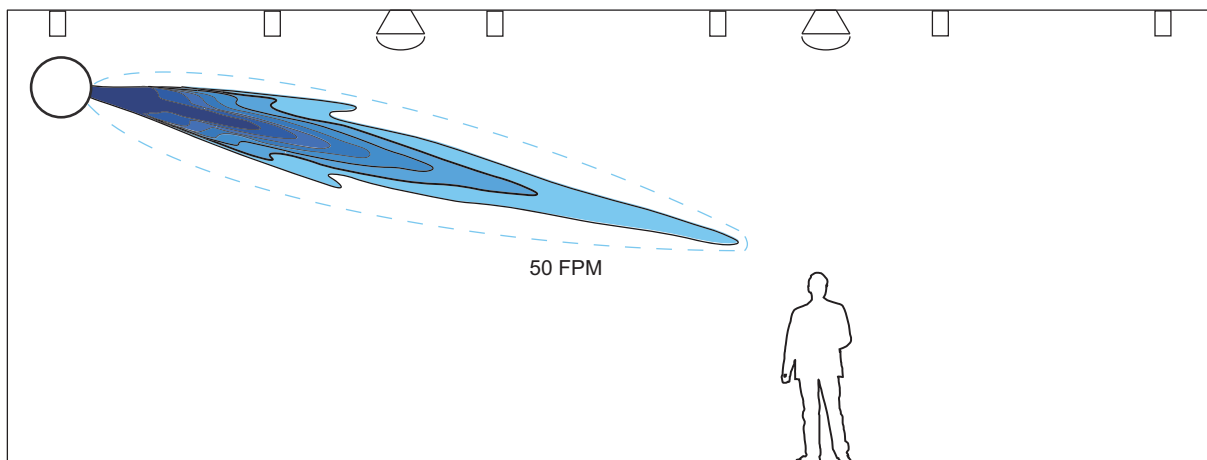
**Figure 3 - Corner Installation Type S0 & S0-HC CFD Heating Analysis**



### Type S0 and S0-HC Corner Cooling Situations

- Cooling CFD Analysis (**Figure 4**) for S0 and S0-HC supply duct located in a corner. The CFD analysis is used to determine the diffusion of air leaving the supply duct and the distance of the throw velocity to 50 ft/min. Duct air temperature 55°F, room air temperature 72°F.
- The cooled air is pushed away from the supply duct rather than dropping directly to the influenced area. This design allows the cooled air to quickly disperse and mix thoroughly in the conditioned space.

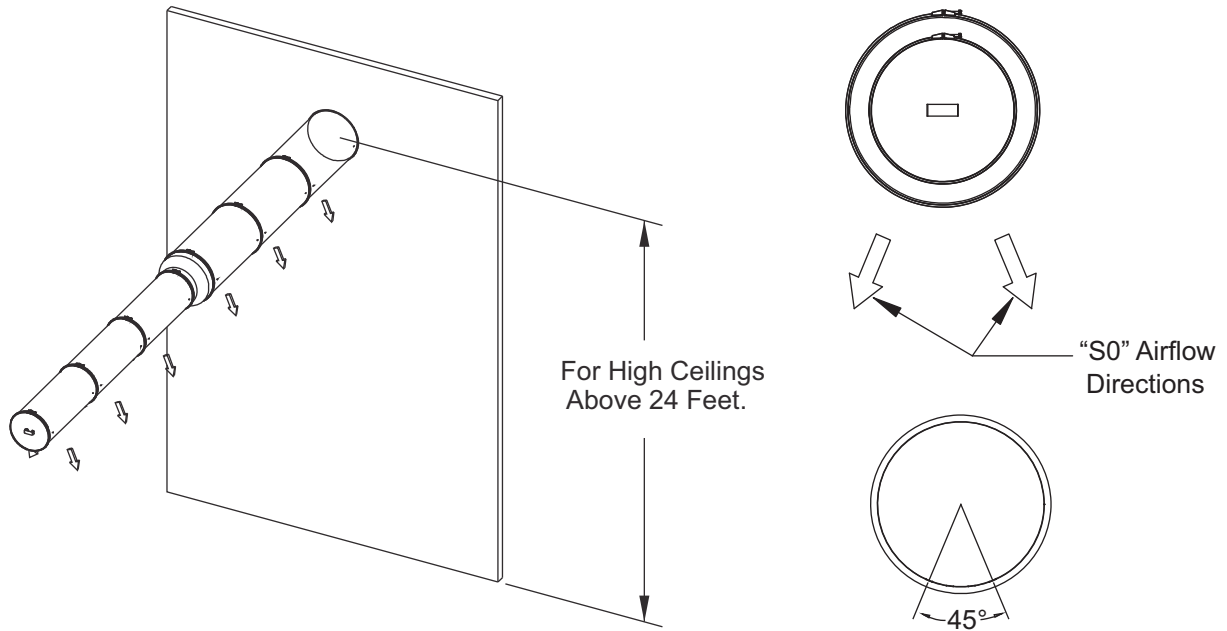
**Figure 4 - Corner Installation Type S0 & S0-HC CFD Cooling Analysis**



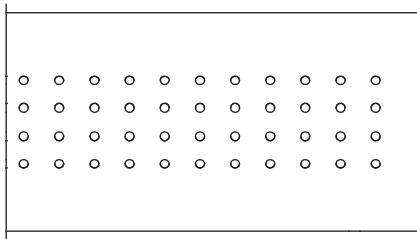
## Supply Duct S0/High Capacity S0-HC - Open Space Installation

0 degree: For high ceilings (above 24 feet), installed in open space to drive air directly downward. The airflow will diffuse from one set of holes into the space, while still avoiding drafts. The air will be diffused from holes located on one side of the duct. The air is directed to the influenced area below. **Figure 5** shows Type S0 and S0-HC supply duct installed in an open space, and the two types of supply duct available. Recommended for rooms with high ceilings above 24 feet.

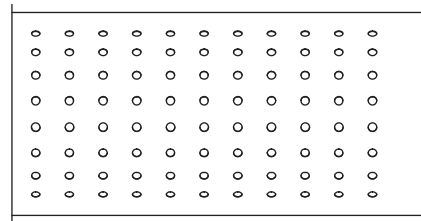
**Figure 5 - S0 & S0-HC Supply Duct Open Space Installation**



**S0 Standard Supply Duct**



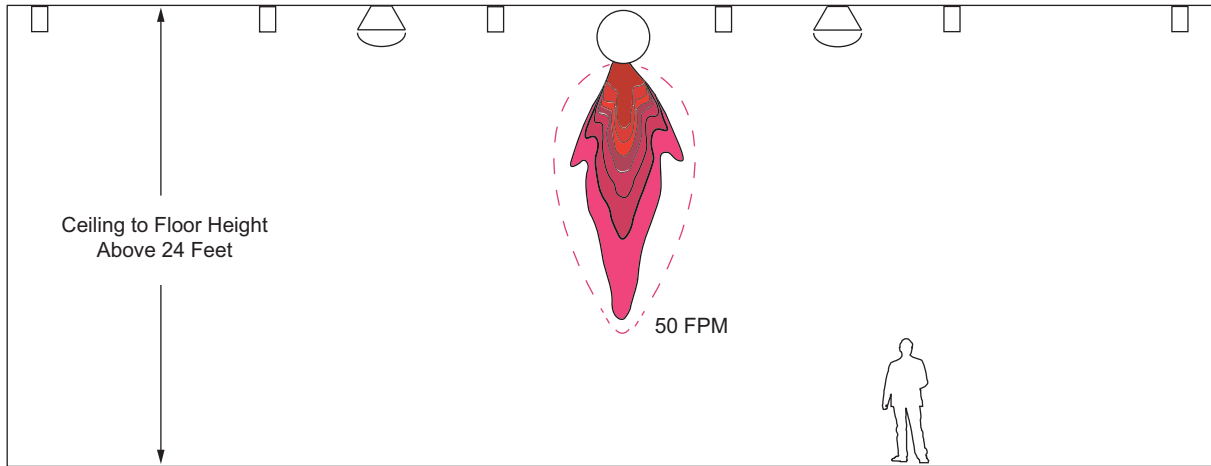
**S0-HC High Capacity Supply Duct**



### Type S0 and S0-HC Open Space Heating Situations

- Heating Computational Fluid Dynamics (CFD) Analysis (**Figure 6**) for S0 and S0-HC supply duct located in an open space. The CFD analysis is used to determine the diffusion of air leaving the supply duct and the distance of the throw velocity to 50 ft/min. Duct air temperature 80°F, room air temperature 70°F.
- No thermal stratification on heating applications, the heated air is quickly dispersed and mixed thoroughly in the conditioned space.

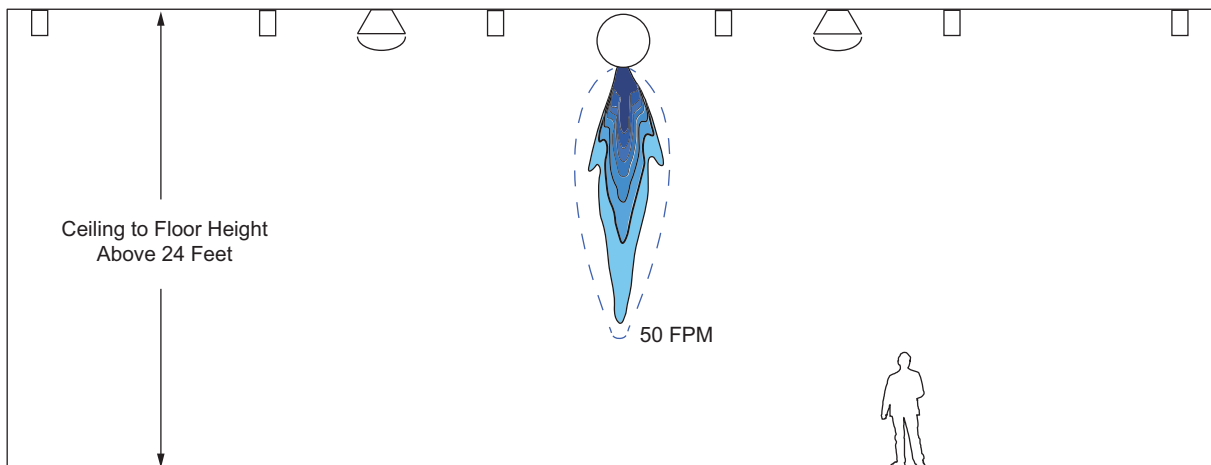
**Figure 6 - Open Space Type S0 & S0-HC CFD Heating Analysis**



### Type S0 and S0-HC Open Space Cooling Situations

- Cooling CFD Analysis (**Figure 7**) for S0 and S0-HC supply duct located in an open space. The CFD analysis is used to determine the diffusion of air leaving the supply duct and the distance of the throw velocity to 50 ft/min. Duct air temperature 55°F, room air temperature 72°F.
- The cooled air is dispersed downward and out, moving directly to the influenced area. This design allows the cooled air to quickly disperse and mix thoroughly in the conditioned space.

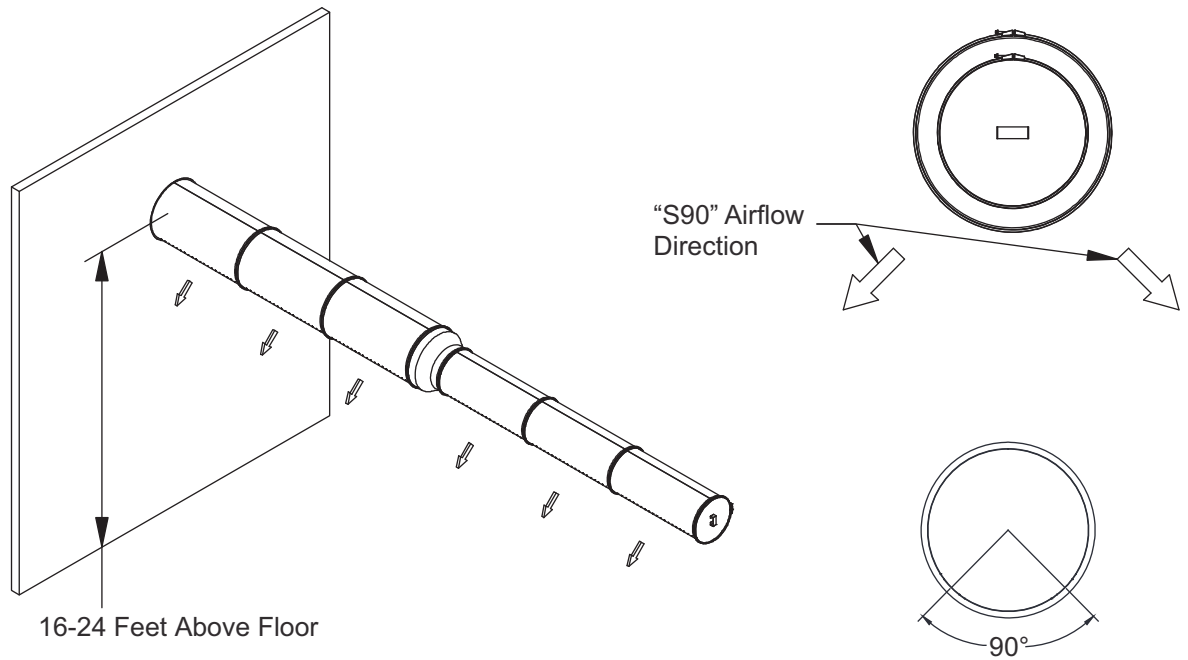
**Figure 7 - Open Space Type S0 & S0-HC CFD Cooling Analysis**



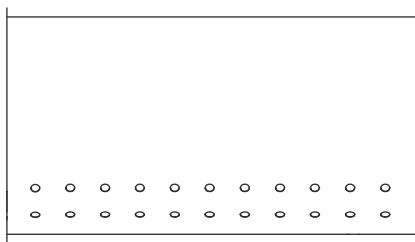
## Supply Duct S90/High Capacity S90-HC - Open Space Installation

90 degree: For mid-height ceilings (16 to 24 feet), installed in open space to drive air downwards, while still avoiding drafts. The air will be diffused from holes on both sides of the supply duct located 90 degrees apart from each other. The air is directed to the influenced area below. **Figure 8** shows Type S90 and S90-HC supply duct installed in an open space with a mid to high ceiling height, and the two types of supply duct available. Recommended for applications such as gyms, multi-use areas, and warehouse spaces with ceiling heights between 16-24 feet.

**Figure 8 - S90 & S90-HC Supply Duct Installation Overview**



**S90 Standard Supply Duct**



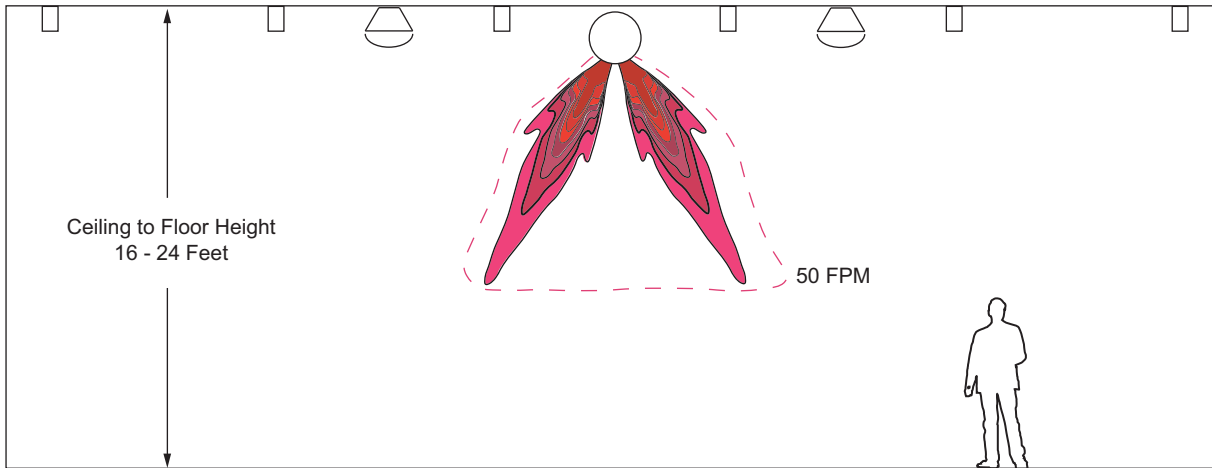
**S90-HC High Capacity Supply Duct**



### Type S90 and S90-HC Center Room Heating Situations

- Heating Computational Fluid Dynamics (CFD) Analysis (**Figure 9**) for S90 and S90-HC supply duct located in an open space. The CFD analysis is used to determine the diffusion of air leaving the supply duct and the distance of the throw velocity to 50 ft/min. Duct air temperature 80°F, room air temperature 70°F.
- No thermal stratification on heating applications, the heated air is quickly dispersed and mixed thoroughly in the conditioned space.

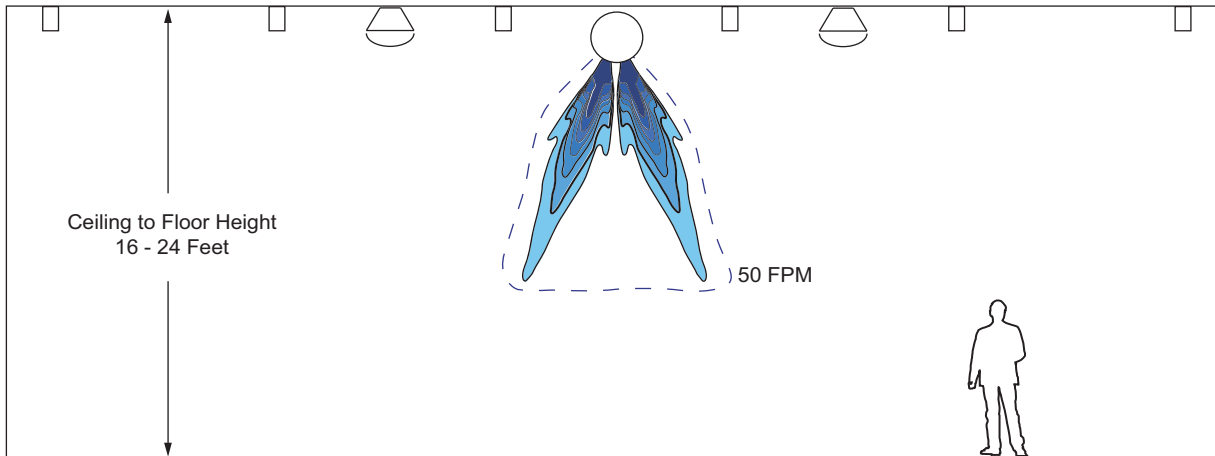
**Figure 9 - Center of Room Type S90 & S90-HC CFD Heating Analysis**



### Type S90 and S90-HC Center Room Cooling Situations

- Cooling CFD Analysis (**Figure 10**) for S90 and S90-HC supply duct located in an open space. The CFD analysis is used to determine the diffusion of air leaving the supply duct and the distance of the throw velocity to 50 ft/min. Duct air temperature 55°F, room air temperature 72°F.
- The cooled air is dispersed through two outlets, downward and out, moving directly to the influenced area. This design allows the cooled air to quickly disperse and mix thoroughly in the conditioned space.

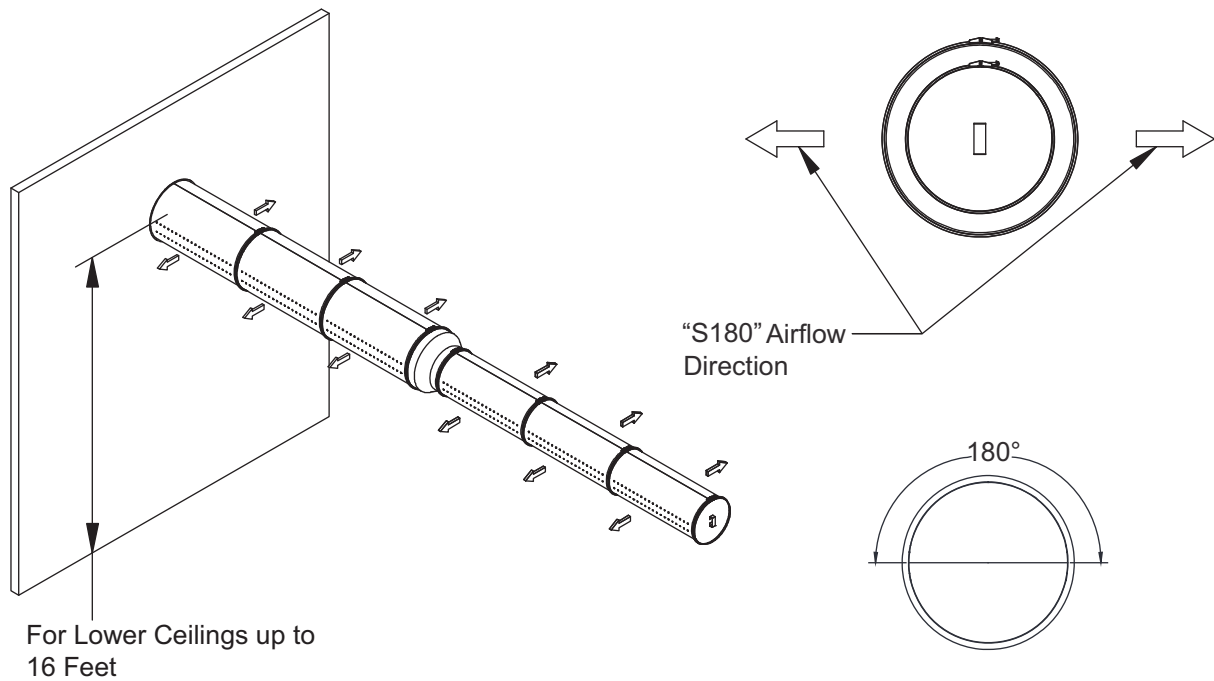
**Figure 10 - Center of Room Type S90 & S90-HC CFD Cooling Analysis**



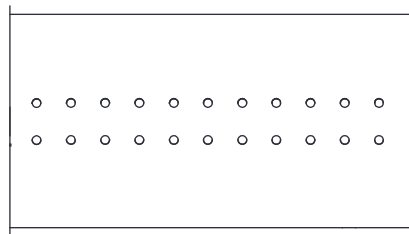
## Supply Duct S180/High Capacity S180-HC - Open Space Installation

For lower ceilings (up to 16 feet), installed in open space to avoid drafts caused by being close to walls. The air will be diffused from holes on both sides of the supply duct located 180 degrees apart from each other. The air is directed from the sides, down to the influenced area. **Figure 11** shows Type S180 and S180-HC supply duct installed in an open space with low ceiling heights, and the two types of supply duct available. Recommended for applications such as office spaces, restaurants, and general commercial space with ceilings up to 16 feet.

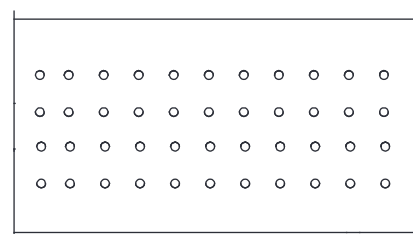
**Figure 11 - S180 & S180-HC Supply Duct Installation Overview**



**S180 Standard Supply Duct**



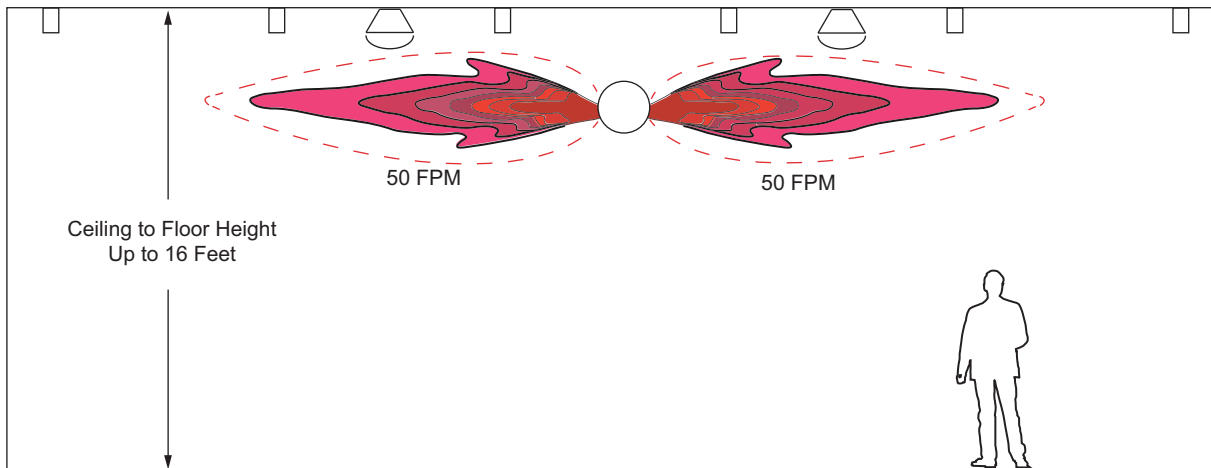
**S180-HC High Capacity Supply Duct**



### S180 and S180-HC Open Space Heating Situations

- Heated Computational Fluid Dynamics (CFD) Analysis (**Figure 12**) for S180 and S180-HC supply duct located in an open space. The CFD analysis is used to determine the diffusion of air leaving the supply duct and the distance of the throw velocity to 50 ft/min. Duct air temperature 80°F, room air temperature 70°F.
- No thermal stratification on heating applications, the heated air is quickly dispersed and mixed thoroughly in the conditioned space.

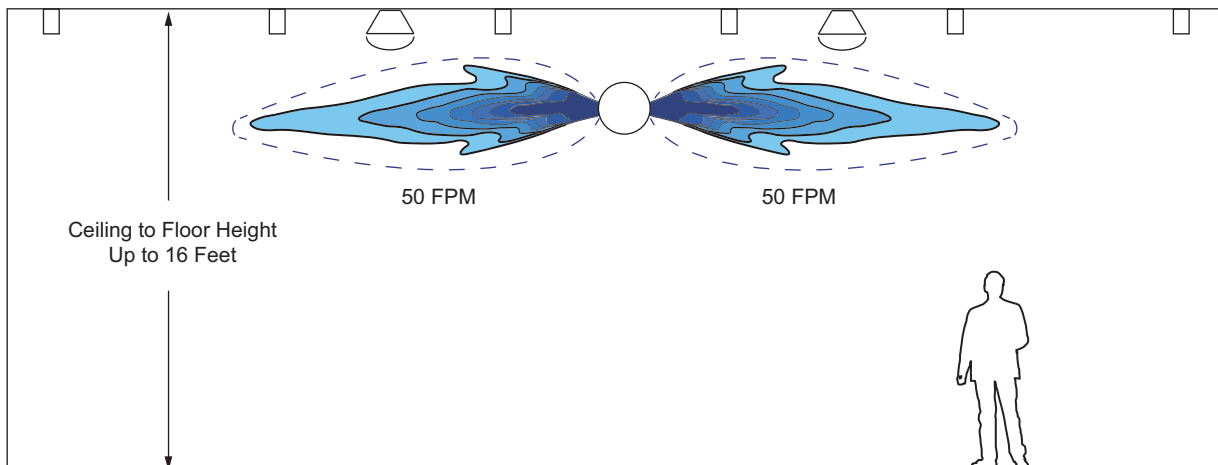
**Figure 12 - Center of Room Type S180 & S180-HC CFD Heating Analysis**



### S180 and S180-HC Open Space Cooling Situations

- Cooling CFD Analysis (**Figure 13**) for S180 and S180-HC supply duct located in an open space. The CFD analysis is used to determine the diffusion of air leaving the supply duct and the distance of the throw velocity to 50 ft/min. Duct air temperature 55°F, room air temperature 72°F.
- The cooled air is pushed away from the supply duct rather than dropping directly to the influenced area, this allows the cooled air to quickly disperse and mix thoroughly in the conditioned space.

**Figure 13 - Center of Room Type S180 & S180-HC CFD Cooling Analysis**



# INSTALLATION

## Joint Gasket

**Proper joint assembly is essential for safe installation. Follow these instructions exactly as written. Verify all joint connections are secure upon completion of assembly.**

The EPDM (Ethylene Propylene Diene Monomer) foam gasket is used to seal duct sections. EPDM is blended with neoprene and SBR (Styrene-Butadiene Rubber) to create a general-purpose foam that offers good resistance to water and wear. This foam has closed-cell construction, which restricts water, air, and gases from being absorbed. Single wall supply duct is sealed using EPDM foam strips. Double wall supply duct uses a one piece die cut gasket. **NO GASKET SUBSTITUTES MAY BE USED.**

Replace gasketing if it becomes loose, damaged, or is not properly sealing.

## Gasket Features

- Superior adhesion, gaskets have a 9485PC PSA (Pressure Sensitive Adhesive) self-stick backing.
- ASTM D1056 2C2 & UL 94HF1 listed.
- Closed-cell construction.
- UV and water-resistant.
- Average feet per roll = 50'.

**Table 2 - Gasket Usage**

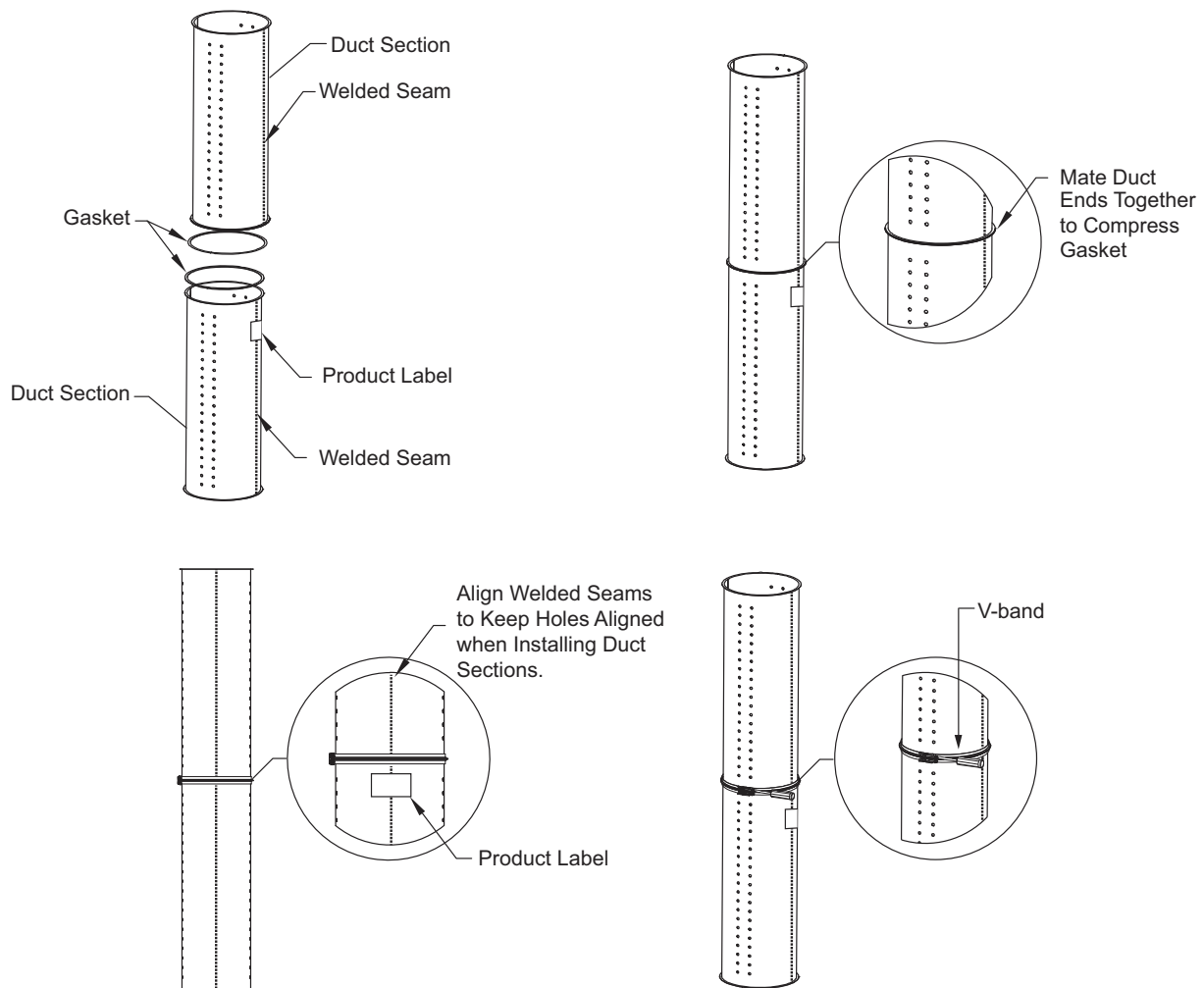
EPDM Foam Strip			
Diameter	Duct Perimeter (Feet)	Gasket Length (Feet)	Joints Per Roll
5"	1.43	2	32
6"	1.70	2	27
7"	1.96	2	24
8"	2.16	2	21
10"	2.68	3	17
12"	3.21	3	15
14"	3.73	4	13
16"	4.25	4	11
18"	4.78	5	10
20"	5.30	5	9
22"	5.83	6	8
24"	6.35	7	8
26"	6.93	7	7
28"	7.46	8	7
30"	7.98	8	6
32"	8.39	9	6
34"	8.91	9	5
36"	9.55	10	5



## Supply Duct Joint Assembly

1. Verify EPDM gasket is installed around the perimeter of the duct. Refer to “**Joint Gasket**” on page 16 for gasketing details.
2. Place the two duct sections together. Make sure the gasket side, with the product label, is connected to the non-gasket side of the other duct section.
3. Align weld seams of the supply duct before installing V-bands, this will help align the supply duct holes.
4. Install the V-band around the duct sections. Both duct flanges should be inside the “V”.
5. For horizontal duct runs, the V-band hardware should be located on the top side of the duct and orientated between the 3 and 9 o’clock position on the duct.
6. NEVER install the V-band with the hardware orientated on the bottom side of the duct on horizontal runs.
7. Secure the V-band around the duct by tightening the 1/4”-20 hardware between **40 - 60 in-lbs**. See **Figure 14** for details.

**Figure 14 - Joint Assembly**

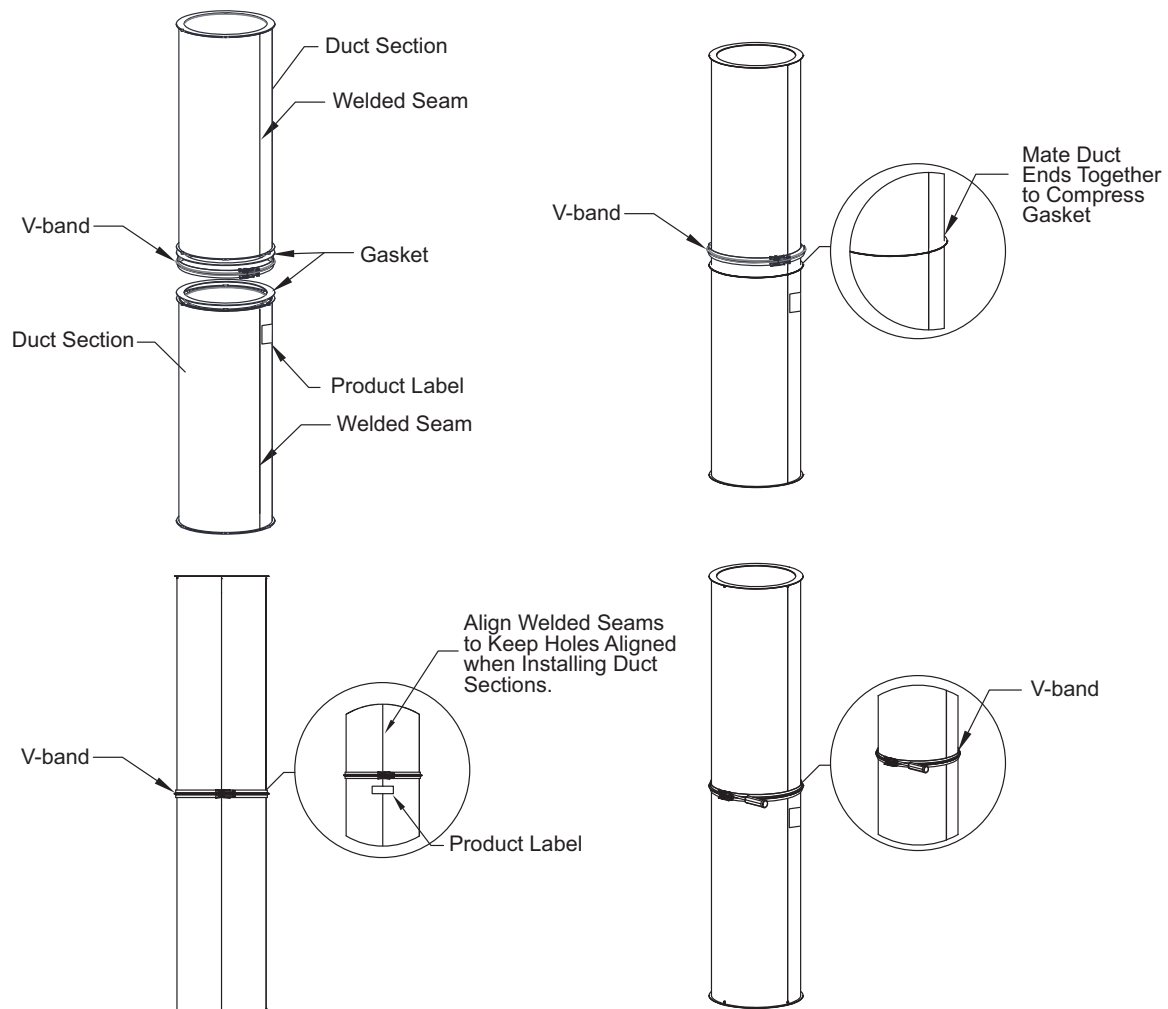


**IMPORTANT: THE HARDWARE USED TO ASSEMBLE THIS DUCTWORK IS SPECIFICALLY DESIGNED FOR THIS APPLICATION. NO SUBSTITUTE HARDWARE IS ALLOWED. ALL REPLACEMENT HARDWARE MUST BE PURCHASED FROM THE FACTORY.**

## Double Wall Supply Duct Joint Assembly

1. Verify EPDM gasket is installed around the perimeter of the duct. Refer to “**Joint Gasket**” on page 16 for gasketing details.
2. Place the two duct sections together. Make sure the gaskets are installed on both sides.
3. Align weld seams of the duct supply before installing V-bands.
4. Install the V-band around the duct sections. Both duct flanges should be inside the “V”.
5. For horizontal duct runs, the V-band hardware should be located on the top side of the duct and orientated between the 3 and 9 o’clock position on the duct.
6. NEVER install the V-band with the hardware orientated on the bottom side of the duct on horizontal runs.
7. Secure the V-band around the duct by tightening the 1/4”-20 hardware between **40 - 60 in-lbs**. See **Figure 15** for details. The V-band can be sealed using 3M Fire Barrier 2000+ Silicone when being installed outside.
8. Supply duct transitions are available when connecting double wall supply duct to single wall supply duct. Joint connections for supply duct transitions are the same as steps 1-7.

**Figure 15 - Double Wall Joint Assembly**



**IMPORTANT: THE HARDWARE USED TO ASSEMBLE THIS DUCTWORK IS SPECIFICALLY DESIGNED FOR THIS APPLICATION. NO SUBSTITUTE HARDWARE IS ALLOWED. ALL REPLACEMENT HARDWARE MUST BE PURCHASED FROM THE FACTORY.**

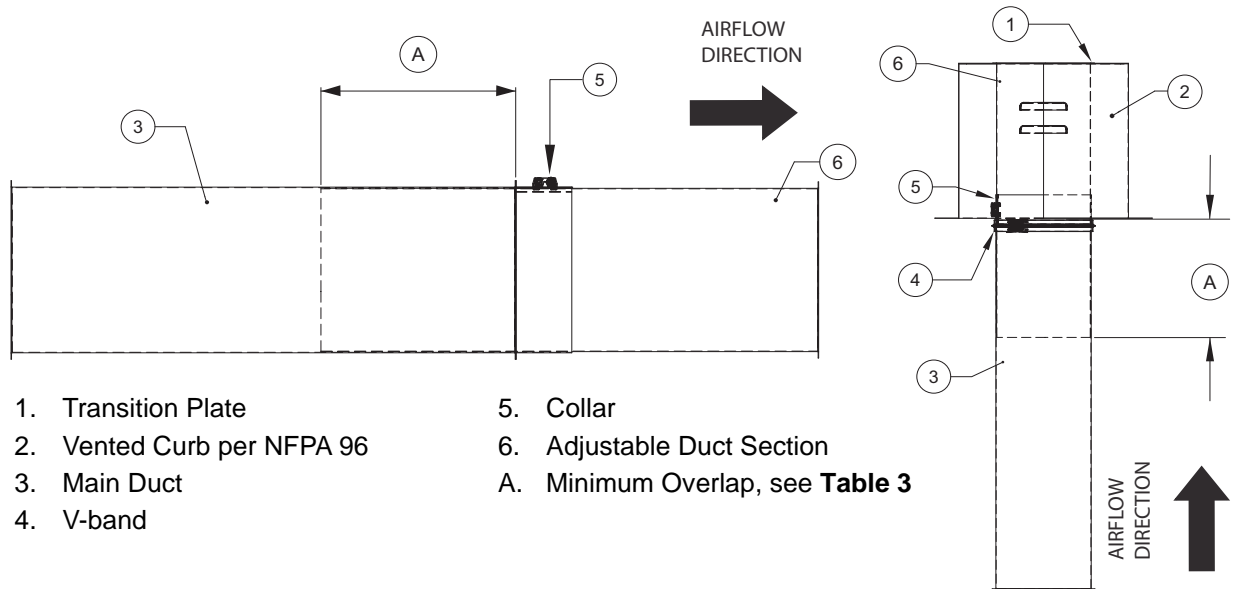
## Single Wall Collar and Adjustable Duct Connections

The collar and adjustable duct length help to make up odd lengths of duct as needed in short runs. Refer to **Figure 16** for adjustable duct assembly details.

The adjustable duct is flanged at one end only. The collar is constructed of the same material as the duct, and is designed with a 1/2" flange that is connected to the standard duct section. Collars are also sealed using EPDM gasketing that compresses around the adjustable duct when the collar hardware is tightened.

If the protruding section interferes with mating parts in the duct run, you will need to field cut the adjustable section. Verify the minimum overlap is set correctly, refer to **Table 3**.

**Figure 16 - Single Wall Adjustable Duct Overlap**



- 1. Transition Plate
- 2. Vented Curb per NFPA 96
- 3. Main Duct
- 4. V-band
- 5. Collar
- 6. Adjustable Duct Section
- A. Minimum Overlap, see **Table 3**

**Table 3 - Minimum Overlap**

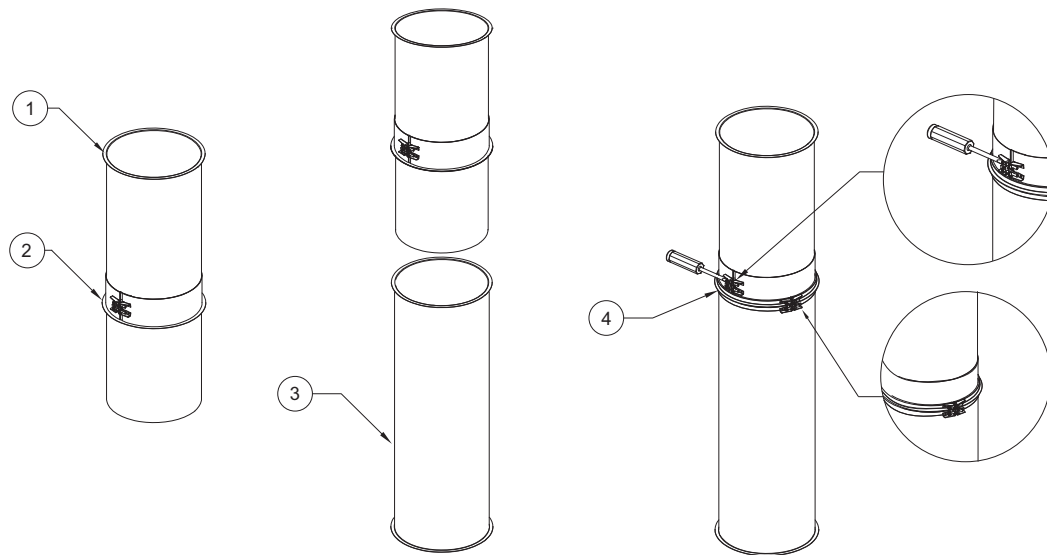
Diameter	Minimum Overlap for Adjustable Duct
5", 6", 7", 8"	4"
10"	5"
12", 14", 16", 18", 20", 22", 24", 26", 28", 30", 32", 34", 36"	6"

## Single Wall Collar and Adjustable Supply Duct Installation

When the adjustable length duct and collar are installed between two fixed points, such as the beginning support and the ending support, it should be installed just below the higher support. To ensure proper axial alignment, wall guide support assemblies must be installed below the duct joint immediately below the adjustable duct. This combination of parts will force the sliding inner and outer parts of the adjustable duct to overcome collar friction, allowing movement along the axis of the duct. This relieves expansion stresses, which would otherwise develop between the fixed points of the heated vertical duct. Refer to **Figure 17** for assembly details.

1. Slide the adjustable collar over the adjustable duct. Flanges should be opposite of each other.
2. Slide the adjustable duct into the standard duct to the point that the collar flange and the standard duct/ chimney flange meet.
3. The adjustable collar and standard duct are joined and sealed using the “**Supply Duct Joint Assembly**” on page 17 method.
4. Slide the adjustable duct into the standard duct to the desired length. If the protruding section interferes with mating parts in the duct run, you will need to cut the adjustable duct section that is interfering with mating parts. Minimum overlap dimensions are specific to the duct diameter. Refer to **Table 3 on page 19** for proper overlap specifications.
5. Install V-clamp. Tighten the 1/4”-20 hardware on the V-clamp and the outside of the adjustable collar between **40 - 60 in-lbs**.
6. Inspect the connection for gaps.

**Figure 17 - Single Wall Collar and Adjustable Duct Installation**



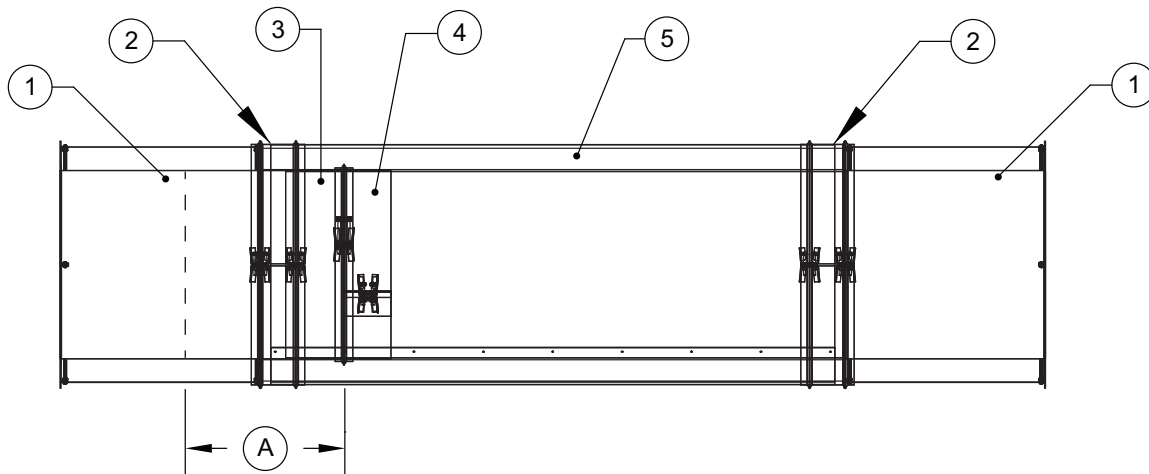
1. Adjustable Duct/Chimney
2. Adjustable Collar

3. Standard Duct
4. "V" Clamp

## Double Wall Adjustable Duct Connections

Adjustable duct lengths are used to make up variable lengths in the duct system(s). Adjustable sections should always be installed with the overlap to the inside of the standard duct section. If the inner adjustable section is too long to fit into the adjacent section of duct without interfering with the flow path, it should be trimmed to the desired flange to flange length. Flange to flange length of adjustment can range from 5" to 26".

Figure 18 - Double Wall Adjustable Duct Overlap



1. Duct
2. Double V-band
3. SW to DW Transition Connection

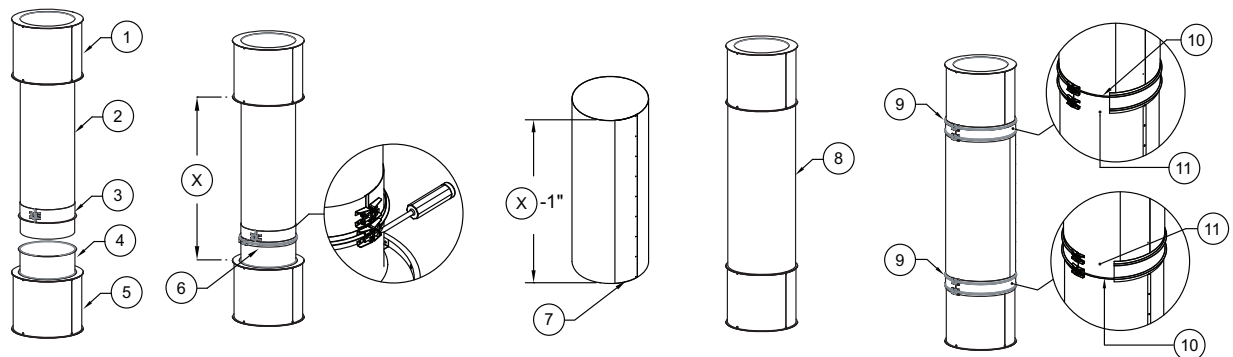
4. Adjustable Collar Secured with Single V-band
5. Outer Shell Cover
- A. Minimum Overlap, see **Table 3 on page 19**

## Double Wall Adjustable Duct Standard Installation

1. The adjustable collar is slipped onto the adjustable duct section. Make sure the adjustable collar flanges are opposite the adjustable duct section flange.
2. The adjustable section is pushed inside the mating duct section. Verify the minimum overlap is set correctly, refer to **Table 3 on page 19**.
3. If the protruding section interferes with mating parts in the duct run, you will need to cut the adjustable section that is interfering with mating parts, refer to **Figure 18 on page 21**.
4. Install single V-band around adjustable collar flange and standard duct flange. Tighten the single V-band hardware to **40-60 in-lbs**.
5. Once the single V-band has been installed, tighten the adjustable collar hardware to **40-60 in-lbs**.
6. Measure the distance between mating duct flanges before installing insulation and outer shell cover.
7. Subtract 1" from the measured distance and cut the pre-rolled shell to this dimension.
8. After the adjustable section has been installed, wrap the assembly using insulation provided. Make sure all voids are adequately filled.
9. Wrap the pre-rolled outer shell cover around the insulation. Ratchet strap(s) may be used around outer shell to aid in compressing insulation.
10. Install the double wall V-band on either end of the assembly. Make sure the double wall V-band is secured onto the mating duct flange and overlapping onto the shell before tightening hardware.
11. The double wall V-band will close the pre-rolled shell as they are tightened. Once closed, secure the outer shell cover along the seam using the 1" sheet metal screws that have been provided.

**NOTE: Outer Shell Must Extend Behind the Double Wall V-band.**

**Figure 19 - Double Wall Collar and Adjustable Duct Installation**



- |                                   |                        |
|-----------------------------------|------------------------|
| 1. Duct Section 1                 | 7. Outer Shell Cover   |
| 2. Adjustable Section             | 8. Insulation          |
| 3. Adjustable Collar              | 9. Double V-band       |
| 4. SW to DW Transition Connection | 10. Mating Duct Flange |
| 5. Duct Section 2                 | 11. Shell Overlap      |
| 6. Single V-band                  | X. Measured Distance   |

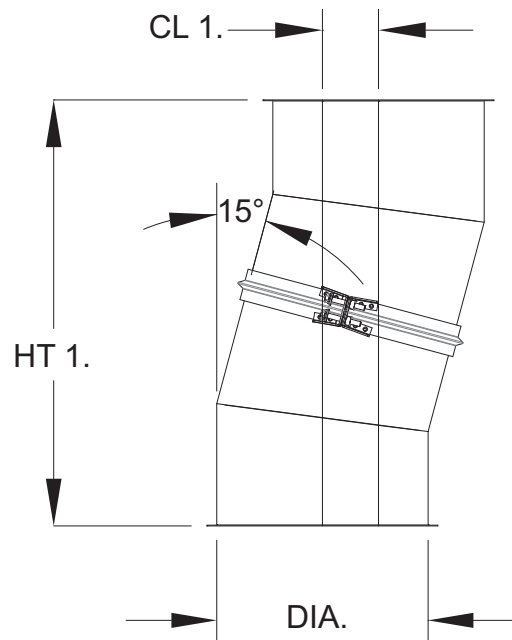
## Single Wall Offset Distance

Refer to **page 23** through **page 25** for single wall offset details.

**Table 4 - Offset Center Line Distance 15 Degree Elbows**

Diameter	Flange Diameter	Part Number	HT 1	CL 1
5"	6"	DW0515ASY	19"	2-1/2"
6"	7"	DW0615ASY	19-1/4"	2-1/2"
7"	8"	DW0715ASY	19-1/2"	2-1/2"
8"	9"	DW0815ASY	19-3/4"	2-1/2"
10"	11"	DW1015ASY	20-3/8"	2-5/8"
12"	13"	DW1215ASY	20-7/8"	2-3/4"
14"	15"	DW1415ASY	21-3/8"	2-7/8"
16"	17"	DW1615ASY	21-7/8"	2-7/8"
18"	19"	DW1815ASY	22-3/8"	3"
20"	21"	DW2015ASY	22-7/8"	3"
22"	23"	DW2215ASY	23-3/8"	3-1/8"
24"	25"	DW2415ASY	23-7/8"	3-1/8"
26"	27"	DW2615ASY	24-1/2"	3-1/4"
28"	29"	DW2815ASY	25"	3-1/4"
30"	31"	DW3015ASY	25-1/2"	3-3/8"
32"	33"	DW3215ASY	26"	3-1/2"
34"	35"	DW3415ASY	26-1/2"	3-1/2"
36"	37"	DW3615ASY	27-1/8"	3-1/2"

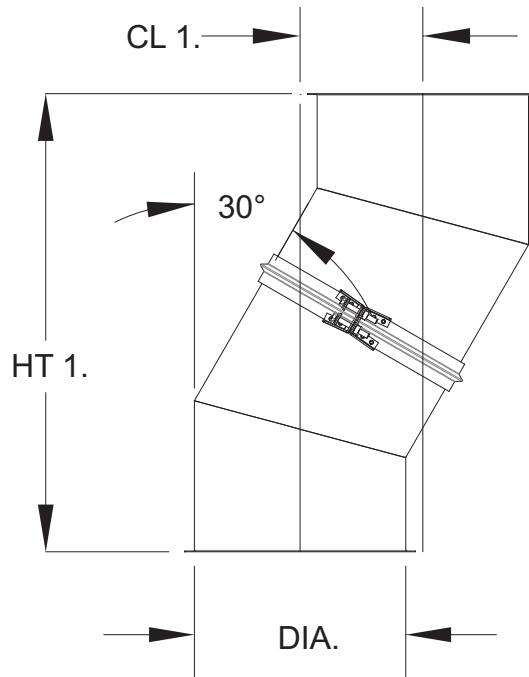
**Figure 20 - 15 Degree Offset Details**



**Table 5 - Offset Center Line Distance 30 Degree Elbows**

Diameter	Flange Diameter	Part Number	HT 1	CL 1
5"	6"	DW0530ASY	19-3/8"	5-1/8"
6"	7"	DW0630ASY	19-7/8"	5-3/8"
7"	8"	DW0730ASY	20-3/8"	5-1/2"
8"	9"	DW0830ASY	20-7/8"	5-1/2"
10"	11"	DW1030ASY	21-7/8"	5-7/8"
12"	13"	DW1230ASY	22-7/8"	6-1/8"
14"	15"	DW1430ASY	23-7/8"	6-3/8"
16"	17"	DW1630ASY	24-7/8"	6-5/8"
18"	19"	DW1830ASY	25-7/8"	7"
20"	21"	DW2030ASY	26-7/8"	7-1/8"
22"	23"	DW2230ASY	27-3/8"	7-3/8"
24"	25"	DW2430ASY	28-7/8"	7-3/4"
26"	27"	DW2630ASY	29-7/8"	8"
28"	29"	DW2830ASY	30-7/8"	8-1/4"
30"	31"	DW3030ASY	31-7/8"	8-1/2"
32"	33"	DW3230ASY	32-7/8"	8-3/4"
34"	35"	DW3430ASY	33-7/8"	9"
36"	37"	DW3630ASY	34-7/8"	9-3/8"

**Figure 21 - 30 Degree Offset Details**

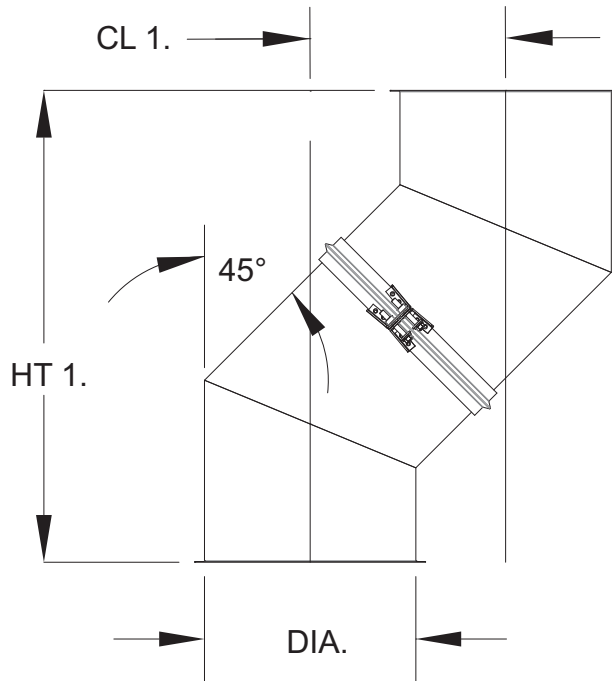




**Table 6 - Offset Center Line Distance 45 Degree Elbows**

Diameter	Flange Diameter	Part Number	HT 1	CL 1
5"	6"	DW0545ASY	18-7/8"	7-7/8"
6"	7"	DW0645ASY	19-5/8"	8-1/8"
7"	8"	DW0745ASY	20-3/8"	8-1/2"
8"	9"	DW0845ASY	21"	8-3/4"
10"	11"	DW1045ASY	22-1/2"	9-3/8"
12"	13"	DW1245ASY	23-7/8"	9-7/8"
14"	15"	DW1445ASY	25-3/8"	10-1/2"
16"	17"	DW1645ASY	26-3/4"	11"
18"	19"	DW1845ASY	28-1/8"	11-5/8"
20"	21"	DW2045ASY	29-1/2"	12-1/4"
22"	23"	DW2245ASY	30"	12-7/8"
24"	25"	DW2445ASY	32-3/8"	13-3/8"
26"	27"	DW2645ASY	33-7/8"	14"
28"	29"	DW2845ASY	35-1/4"	14-1/4"
30"	31"	DW3045ASY	36-5/8"	15-1/4"
32"	33"	DW3245ASY	38"	15-3/4"
34"	35"	DW3445ASY	39-1/2"	16-3/8"
36"	37"	DW3645ASY	40-7/8"	17"

**Figure 22 - 45 Degree Offset Details**



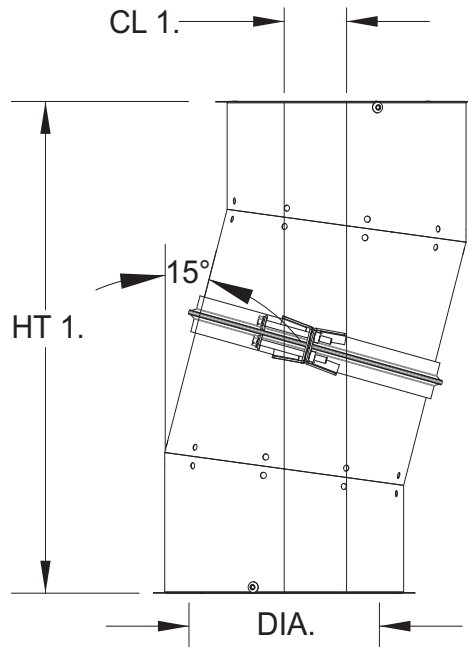
## Double Wall Offset Distance

Refer to **page 26** through **page 28** for double wall offset details.

**Table 7 - Offset Center Line Distance 15 Degree Elbows**

Diameter	Flange Diameter	Part Number	HT 1	CL 1
5"	6"	DW0515DWASY	19"	2-1/2"
6"	7"	DW0615DWASY	19-1/4"	2-1/2"
7"	8"	DW0715DWASY	19-1/2"	2-1/2"
8"	9"	DW0815DWASY	19-3/4"	2-1/2"
10"	11"	DW1015DWASY	20-3/8"	2-5/8"
12"	13"	DW1215DWASY	20-7/8"	2-3/4"
14"	15"	DW1415DWASY	21-3/8"	2-7/8"
16"	17"	DW1615DWASY	21-7/8"	2-7/8"
18"	19"	DW1815DWASY	22-3/8"	3"
20"	21"	DW2015DWASY	22-7/8"	3"
22"	23"	DW2215DWASY	23-3/8"	3-1/8"
24"	25"	DW2415DWASY	23-7/8"	3-1/8"
26"	27"	DW2615DWASY	28-1/4"	3-1/4"
28"	29"	DW2815DWASY	28-7/8"	3-1/4"
30"	31"	DW3015DWASY	25-1/2"	3-3/8"
32"	33"	DW3215DWASY	26"	3-1/2"
34"	35"	DW3415DWASY	26-1/2"	3-1/2"
36"	37"	DW3615DWASY	27-1/8"	3-1/2"

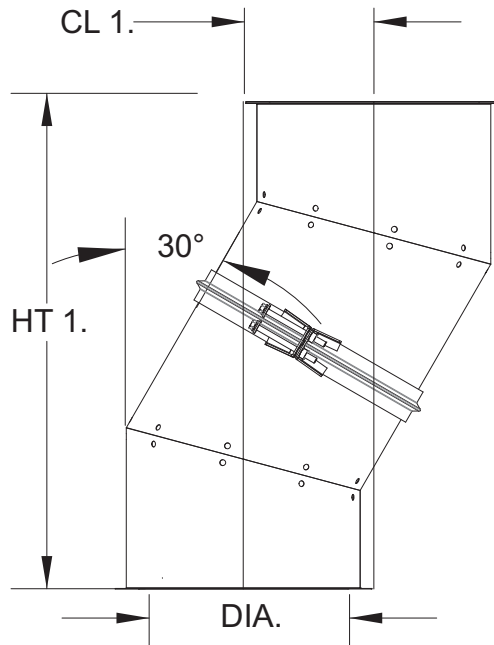
**Figure 23 - 15 Degree Offset Details**



**Table 8 - Offset Center Line Distance 30 Degree Elbows**

Diameter	Flange Diameter	Part Number	HT 1	CL 1
5"	6"	DW0530DWASY	19-3/8"	5-1/8"
6"	7"	DW0630DWASY	19-7/8"	5-3/8"
7"	8"	DW0730DWASY	20-3/8"	5-1/2"
8"	9"	DW0830DWASY	20-7/8"	5-1/2"
10"	11"	DW1030DWASY	21-7/8"	5-7/8"
12"	13"	DW1230DWASY	22-7/8"	6-1/8"
14"	15"	DW1430DWASY	23-7/8"	6-3/8"
16"	17"	DW1630DWASY	24-7/8"	6-5/8"
18"	19"	DW1830DWASY	25-7/8"	7"
20"	21"	DW2030DWASY	26-7/8"	7-1/8"
22"	23"	DW2230DWASY	27-3/8"	7-3/8"
24"	25"	DW2430DWASY	28-7/8"	7-3/4"
26"	27"	DW2630DWASY	29-7/8"	8"
28"	29"	DW2830DWASY	30-7/8"	8-1/4"
30"	31"	DW3030DWASY	31-7/8"	8-1/2"
32"	33"	DW3230DWASY	32-7/8"	8-3/4"
34"	35"	DW3430DWASY	33-7/8"	9"
36"	37"	DW3630DWASY	34-7/8"	9-3/8"

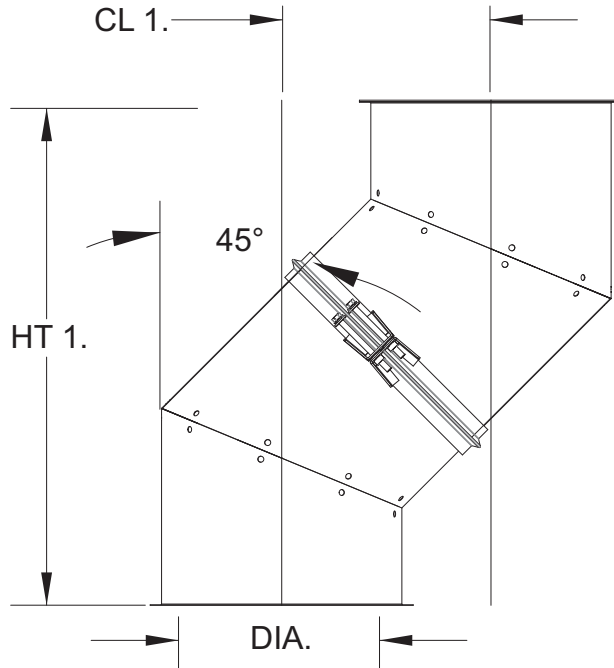
**Figure 24 - 30 Degree Offset Details**



**Table 9 - Offset Center Line Distance 45 Degree Elbows**

Diameter	Flange Diameter	Part Number	HT 1	CL 1
5"	6"	DW0545DWASY	18-7/8"	7-7/8"
6"	7"	DW0645DWASY	19-5/8"	8-1/8"
7"	8"	DW0745DWASY	20-3/8"	8-1/2"
8"	9"	DW0845DWASY	21"	8-3/4"
10"	11"	DW1045DWASY	22-1/2"	9-3/8"
12"	13"	DW1245DWASY	23-7/8"	9-7/8"
14"	15"	DW1445DWASY	25-3/8"	10-1/2"
16"	17"	DW1645DWASY	26-3/4"	11"
18"	19"	DW1845DWASY	28-1/8"	11-5/8"
20"	21"	DW2045DWASY	29-1/2"	12-1/4"
22"	23"	DW2245DWASY	30"	12-7/8"
24"	25"	DW2445DWASY	32-3/8"	13-3/8"
26"	27"	DW2645DWASY	33-7/8"	14"
28"	39"	DW2845DWASY	35-1/4"	14-1/4"
30"	31"	DW3045DWASY	36-5/8"	15-1/4"
32"	33"	DW3245DWASY	38"	15-3/4"
34"	35"	DW3445DWASY	39-1/2"	16-3/8"
36"	37"	DW3645DWASY	40-7/8"	17"

**Figure 25 - 45 Degree Offset Details**



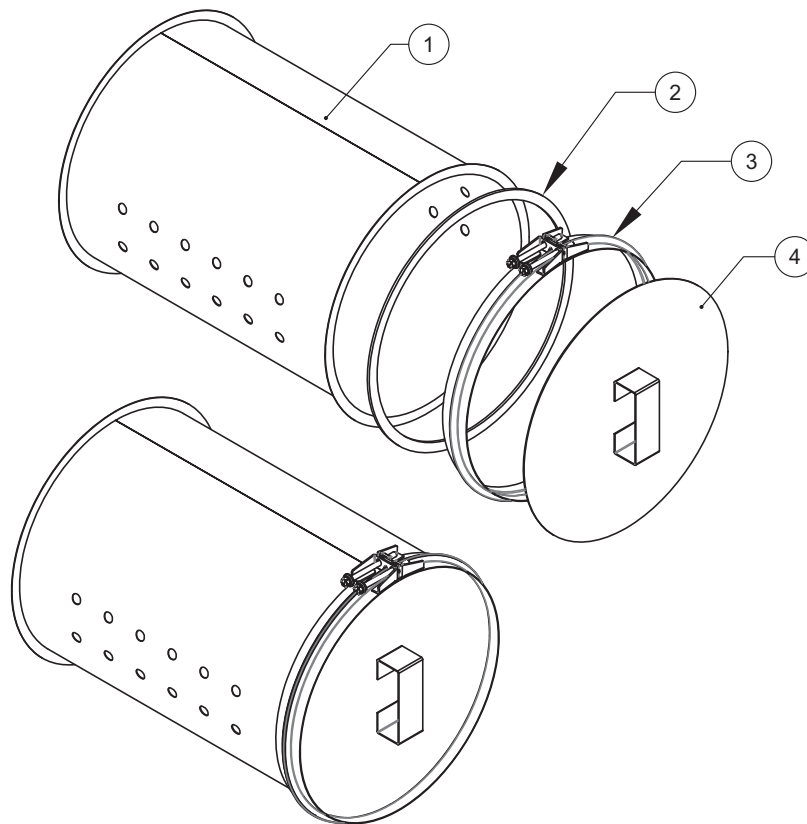
## Single Wall Supply Duct Access Door Assembly

Access doors are available in sizes 5" to 36" (Figure 26). The connection is the same as the joint assembly method shown in "Single Wall Collar and Adjustable Supply Duct Installation" on page 20; however, the installation of the access door is slightly different. Read the following instructions very carefully.

1. The access door will always be installed at the end of a duct run. The duct run will always end with a supply duct section, do not end a duct run with a blank section.
2. The final duct run joint will be connected, as shown in "Single Wall Collar and Adjustable Supply Duct Installation" on page 20, except for the access door.
3. Apply the proper gasket to the flange of the duct that will be used for an access door.
4. Center the supplied EPDM gasket over the duct end. Push the gasket down to secure the gasket to the duct flange.
5. Once the gasket is secured, attach the access door using a V-band. Verify flanges are in the "V" before tightening 1/4"-20 hardware. Tighten between 40 - 60 in-lbs.

Figure 26 - Single Wall Access Door Assembly

1. Supply Duct
2. EPDM Gasket
3. V-band
4. Access Door



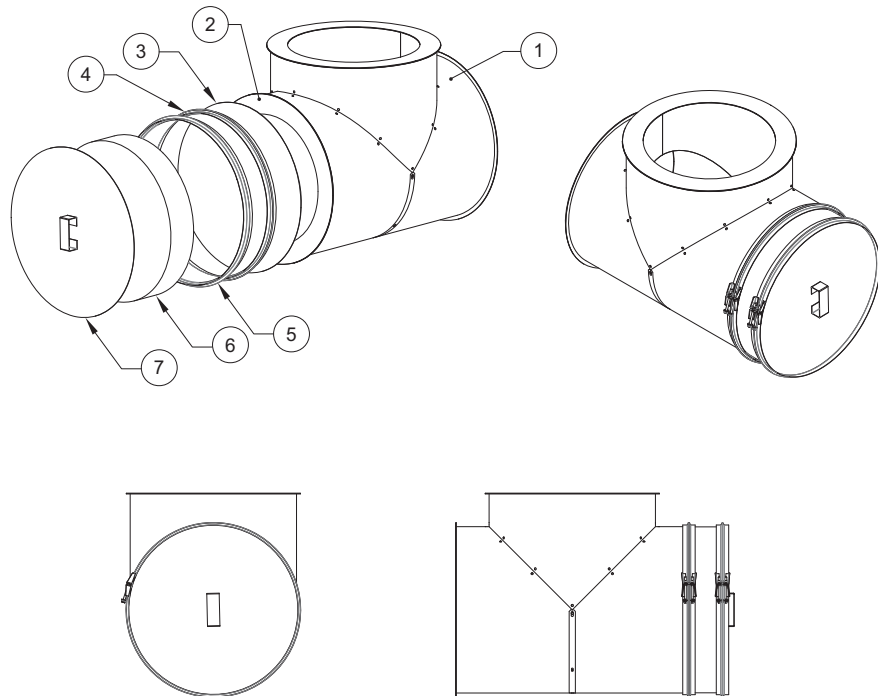
## Double Wall Supply Duct Access Door Assembly

Access doors are available in sizes 5" to 36" (**Figure 27**). The connection is the same as the joint assembly method shown in "**Double Wall Supply Duct Joint Assembly**" on **page 18**; however, the installation of the access door is slightly different. Read the following instructions very carefully.

1. The access door is installed at the end of the duct tee for access into central locations of duct.
2. The final duct run joint will be connected, as shown in "**Double Wall Supply Duct Joint Assembly**" on **page 18**, except for the access door.
3. Center inner access door. Press inner access door onto EPDM gasket to secure in place and press outer duct shell onto inner access door.
4. Attach the access door and outer duct shell using a V-band. Verify flanges are in the "V" before tightening 1/4"-20 hardware. Tighten between **40 - 60 in-lbs**.
5. Apply gasket to open flange of outer duct shell.
6. Center outer access door. Press outer access door onto gasket to secure in place.
7. Attach the access door using a V-band. Verify flanges are in the "V" before tightening 1/4"-20 hardware. Tighten between **40 - 60 in-lbs**.

**Figure 27 - Access Door Assembly**

1. Tee
2. Gasket
3. Inner Access Door
4. Inner V-band
5. Outer V-band
6. Insulation
7. Outer Access Door



## Supply Duct Noise Reducers

Supply Duct Noise Reducers, also referred to as a sound attenuator, sound trap, or muffler, are for use in supply duct applications where noise suppression is required. Silencers are designed to reduce transmission of noise through ductwork, either from equipment into occupied spaces located in buildings, or between occupied spaces. Duct silencers with acoustic insulation are considered dissipative silencers. Dissipative silencers attenuate sound by transferring sound energy to heat.

This is a common application in locations such as hotels, offices, libraries, schools, and museums where low levels of sound are required. System design should be done without silencers in mind, selecting the quietest possible equipment for the job. Silencers should only be added/ designed into the system if desired sound levels cannot be maintained via the mechanical equipment. Duct silencers are typically installed close to/near ducted mechanical equipment, to prevent noise propagation down-stream. Duct silencers can also be used outdoors. Large equipment may require an array of duct silencers, also known as an attenuator bank. **Table 10 on page 32** provides guidance on equivalent sound levels for space/room types.

### Main Benefits of Supply Duct Noise Reducers:

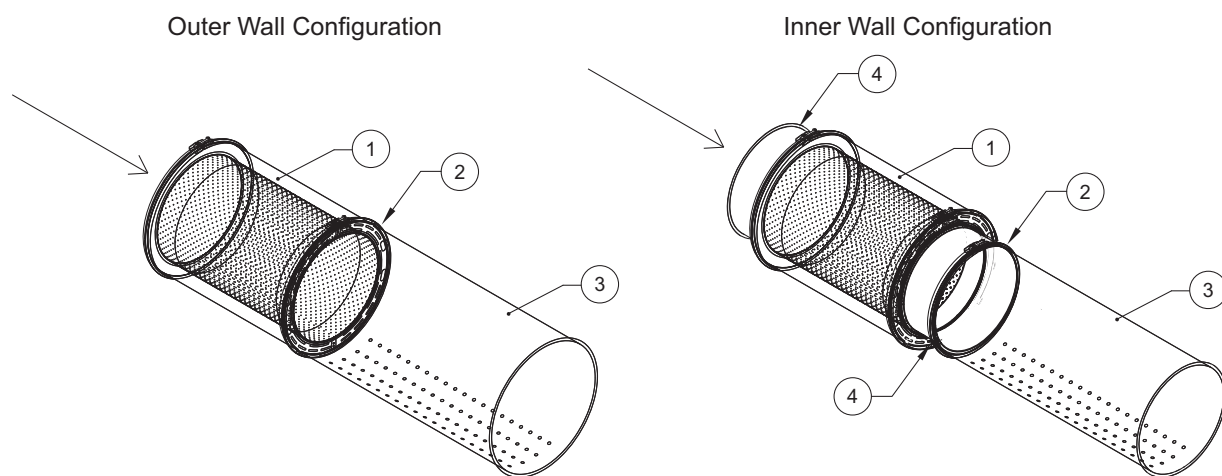
- Reduced space sound levels - Minimized mechanical sound penetration into space.
- Minimal pressure/velocity drop through the silencer compared to other designs.
- Simple drop-in replacements for current/previously installed duct.
- Adaptable to all sizes of ductwork.

### Selection Parameters

Supply Duct Noise Reducers should only be added/ designed into the system if desired sound levels cannot be maintained via the mechanical equipment.

- **Space Available:** Determine the amount of space available around the duct. Refer to **Figure 28** and select Inline or Adapter connection depending on space around the duct.
- **Location:** Supply Duct Noise Reducers should be located no closer than 3x the diameter from the unit location. If possible, insert reducers after T's or bends in the duct work that cause turbulence and propagation of noise.
- **Silencer Array:** Determine if it is possible/necessary to install two or more silencers in series, allowing for maximum sound attenuation. Desired length of silencer is 3x the diameter of the duct (ie. 12" diameter duct = >36" silencer length).

**Figure 28 - Inline or Adapter Connections**



1. Noise Reducer
2. V-Band
3. Supply Duct

4. End Cap.

**Table 10 - Recommended dB(A) values for various types of spaces**

Space Type	Room Type	Equivalent Sound Level
Large Gathering Areas	Apartments	35-45
	Assembly Halls	35-40
	Churches	40-45
	Courtrooms	40-50
	Factories	50-75
Hotels/Motels	Individual Rooms/Suites	35-45
	Meeting/Banquet Rooms	35-45
	Service/Support Areas	45-50
	Halls, Corridors, Lobbies	50-55
Offices	Conference Rooms	35-40
	Private	40-45
	Open-plan Areas	45-50
	Business Machines/Computers	50-55
Hospitals/Clinics	Private Rooms	35-40
	Operating Rooms	35-40
	Wards	40-45
	Laboratories	45-50
	Corridors	40-45
	Public Areas	45-50
Schools	Lecture/Classrooms	35-40
	Open-plan Classrooms	45-50
Other	Movie Theaters	40-45
	Libraries	40-50
	Theater/Playhouse	30-65
	Private Residences	35-45
	Restaurants	50-55
	TV Studios	25-35
	Recording Studio	25-30
	Concert/Recital Hall	25-30
Sports Complex	55-65	



## Single Wall Vertical Support Spacing and Wall Guide Support

**IMPORTANT:** Vertical supports shown in this manual (page 34 through page 38) are recommended. Supports by others must be approved by the Manufacturer and AHJ. Support spacing must be as stated in this manual.

The wall guide is constructed of 12-gauge steel and is comprised of a full ring, brackets, angle struts, wall support plates, and hardware for assembly (includes mounting hardware to secure supports to gypsum walls constructed using 25-gauge steel studs), see **Figure 29**. The ring, which is split into two halves for ease of assembly, is constructed of 12-gauge steel. With the addition of a spacer between the two halves, the diameter is 1/8" larger than the outside diameter of the duct.

The wall support should be installed at the joint of the duct and below the V-band so that the V-band moves away from the support ring. The side struts may be placed either up or down, as is convenient. This assembly is intended to resist lateral or side loads only, and is not for carrying the weight of the vertical duct. The horizontal struts allow for attachment to the wall after the duct has been positioned. The angle of attachment may vary as needed for the duct to wall clearance. Wall supports shall be used at the proper spacing shown in **Table 11** for vertical duct support.

**Table 11 - Single Wall Vertical Support Spacing**

Model	Diameter (Inches)	Vertical Wall Support Spacing (Feet)	Vertical Curb/Floor Support Spacing (Feet)
S, S0 (HC), S90 (HC), S180 (HC)	5", 6", 7", 8", 10", 12", 14", 16", 18", 20", 22", 24", 26", 28", 30", 32", 34", 36"	10'	20'

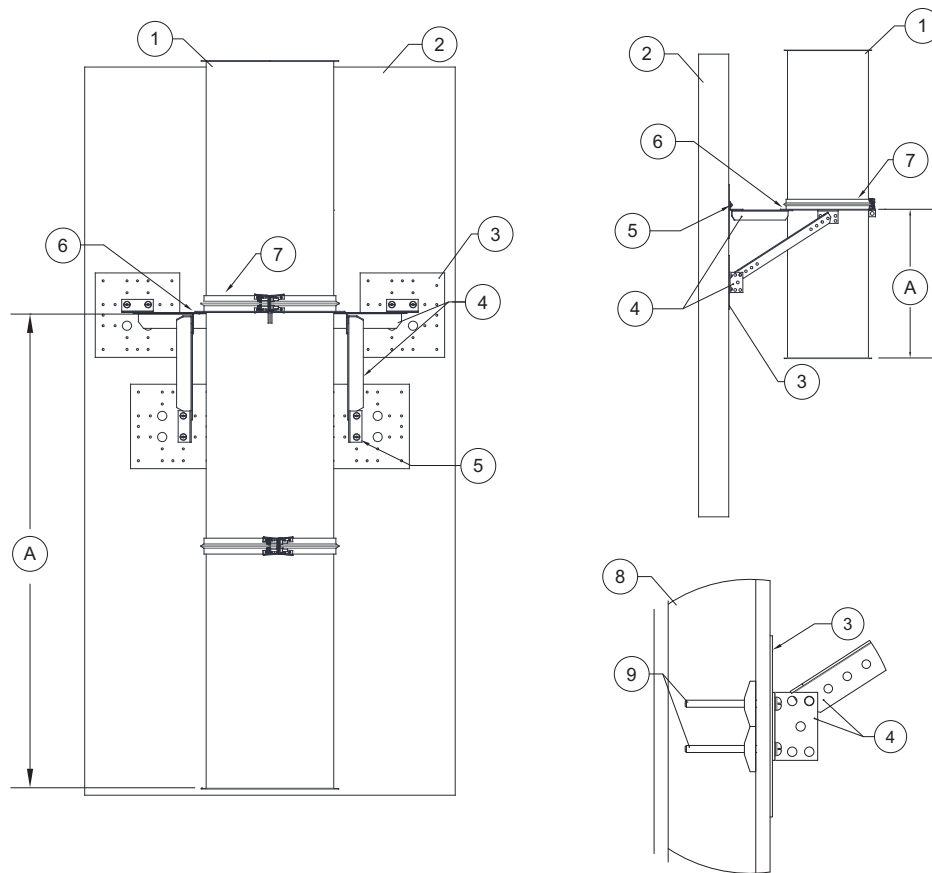
**Vertical support systems must be attached only to the building structure or supported with rigid structural members. Refer to Table 11 for maximum support spacing. It is recommended that vertical support systems are attached to block, concrete, or steel with clearance that is adequate for installation and access.**

## Single Wall Vertical Wall Support (Wood, Concrete, Steel)

**IMPORTANT:** Vertical supports shown in this manual (Figure 29 through Figure 33) are recommended. Supports by others must be approved by the Manufacturer and AHJ. Support spacing must be as stated in this manual.

1. Determine the wall material that the duct will be attached to. This may be gypsum, wood, or concrete.
2. Wall support plates are used to distribute weight when installed on gypsum. Support struts are used to support the duct assembly and to connect the wall support plates and brackets.
3. Locate the support bracket assembly.
4. Mark the location and drill clearance holes. Use supplied hardware to assemble supports.
5. To install supports to wall, use the appropriate hardware kit:
  - Use kit DWVESU-HARDWARE-CM for concrete or masonry wall construction
  - Use kit DWVESU-HARDWARE-S for steel gauge wall construction
  - Use kit DWVESU-HARDWARE-W for wooden wall construction
6. Make sure the duct V-band is installed above the support ring.

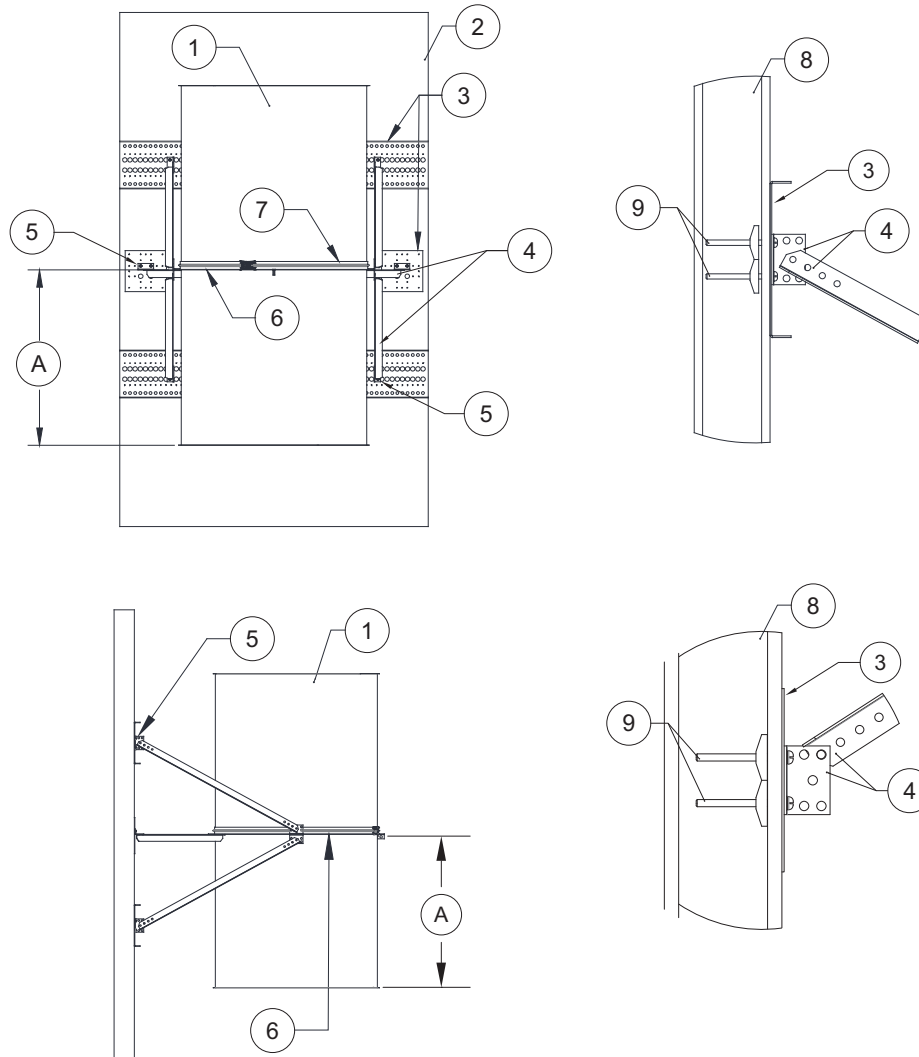
**Figure 29 - Vertical Wall Support (5"-24")**



1. Duct.
2. Wall Material (Gypsum, Wood, Concrete).
3. Wall Support Mounts.
4. Support Struts.
5. 5/16"-18 Hardware by Others.
6. Support Ring.
7. V-band.
8. Open Wall.
9. 5/16" x 4" Long Toggle Bolts - used for open wall cavities.
- A. Vertical Support Spacing, refer to **Table 12** or **page 38**.

**IMPORTANT:** Vertical supports shown in this manual (Figure 29 through Figure 33) are recommended. Supports by others must be approved by the Manufacturer and AHJ. Support spacing must be as stated in this manual.

**Figure 30 - Additional Wall Support Details (26”-36”)**

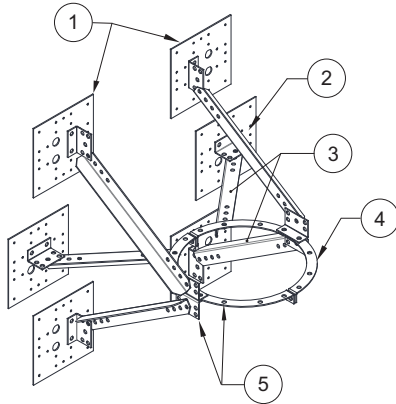


- |  |  |
|--|--|
| <ol style="list-style-type: none"> <li>1. Duct.</li> <li>2. Wall Material (Gypsum, Wood, Concrete).</li> <li>3. Wall Support Mounts.</li> <li>4. Support Struts.</li> <li>5. 5/16”-18 (hardware by others).</li> <li>6. Support Ring.</li> <li>7. V-band.</li> </ol> | <ol style="list-style-type: none"> <li>8. Open Wall.</li> <li>9. 5/16” x 4” Long Toggle Bolts - used for open wall cavities.</li> <li>A. Vertical Support Spacing, refer to <b>Table 12 on page 38</b>.</li> </ol> |
|--|--|

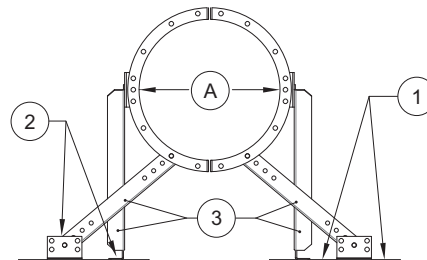
**IMPORTANT:** Vertical supports shown in this manual (Figure 29 through Figure 33) are recommended. Supports by others must be approved by the Manufacturer and AHJ. Support spacing must be as stated in this manual.

**Figure 31 - Vertical Support Details**

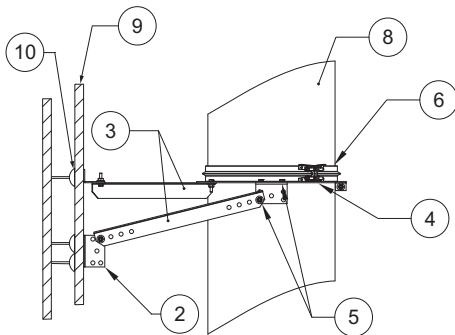
Vertical Support with Additional Supports



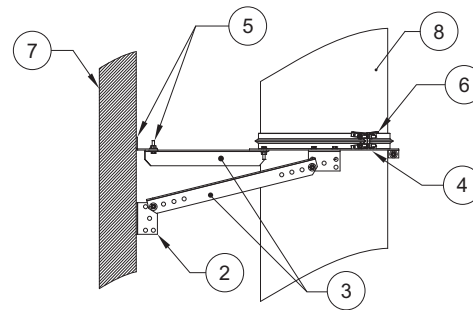
Vertical Support - Bottom View



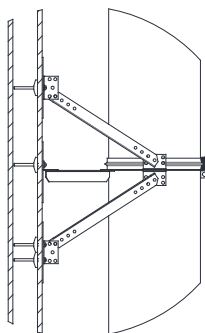
5"-24" Vertical Support Shown



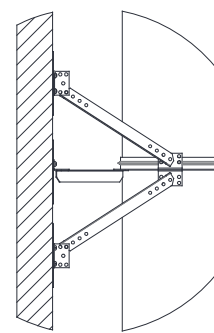
5"-24" Vertical Support Shown



26"-36" Vertical Support Shown



26"-36" Vertical Support Shown



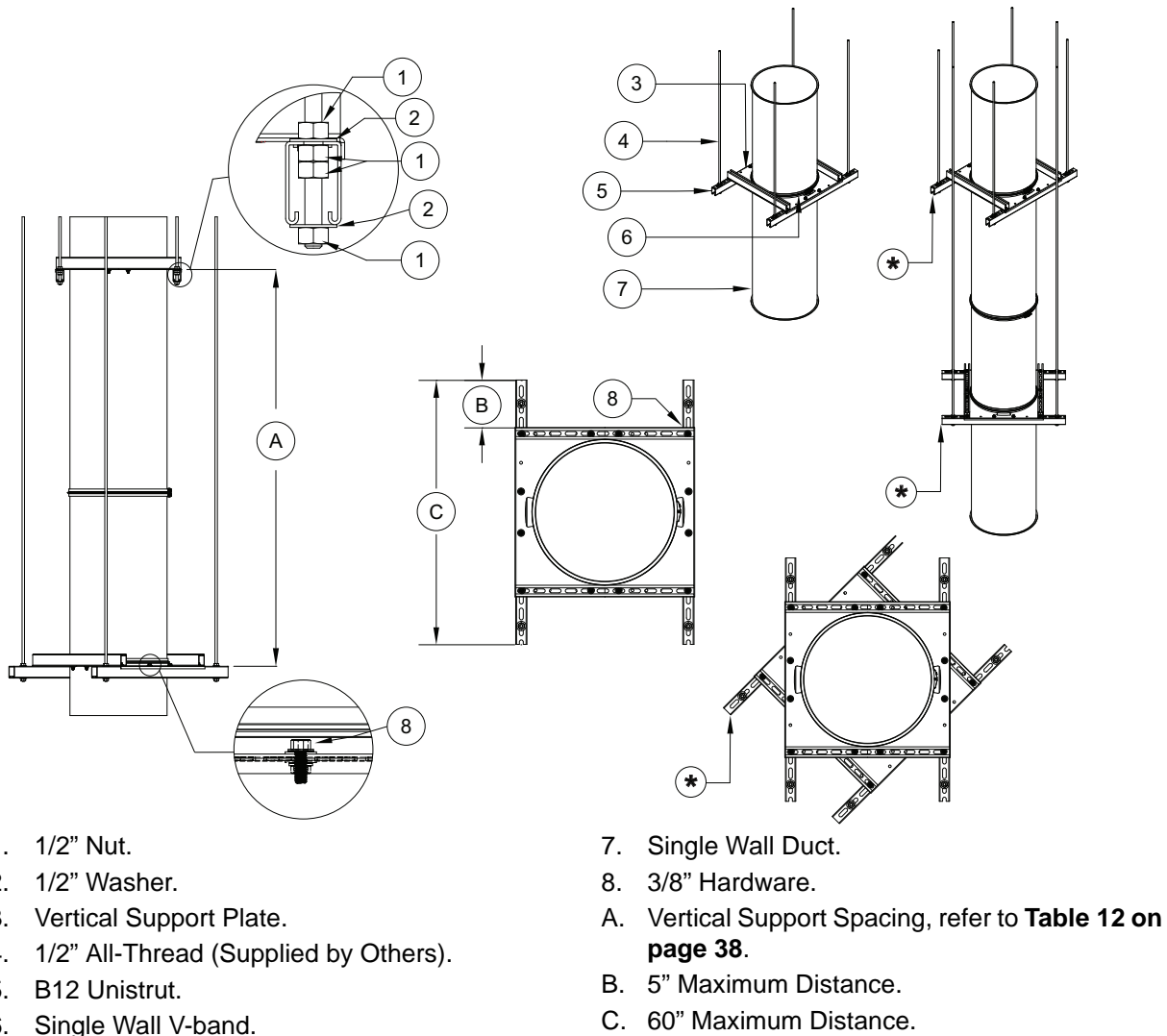
1. Additional Wall Support for 30"/36".
2. Standard Wall Support for 5"-36".
3. Strut.
4. Full Support Ring.
5. 5/16"-18 Hardware.
6. V-band.

7. Solid Wall.
8. Duct.
9. Open Wall Gypsum.
10. 5/16" x 4" Toggle Bolt - used for open wall cavities.
- A. Duct Outer Diameter (OD) + 1/8".

## Single Wall Floor Support

**IMPORTANT:** Vertical supports shown in this manual (Figure 29 through Figure 33) are recommended. Supports by others must be approved by the Manufacturer and AHJ. Support spacing must be as stated in this manual.

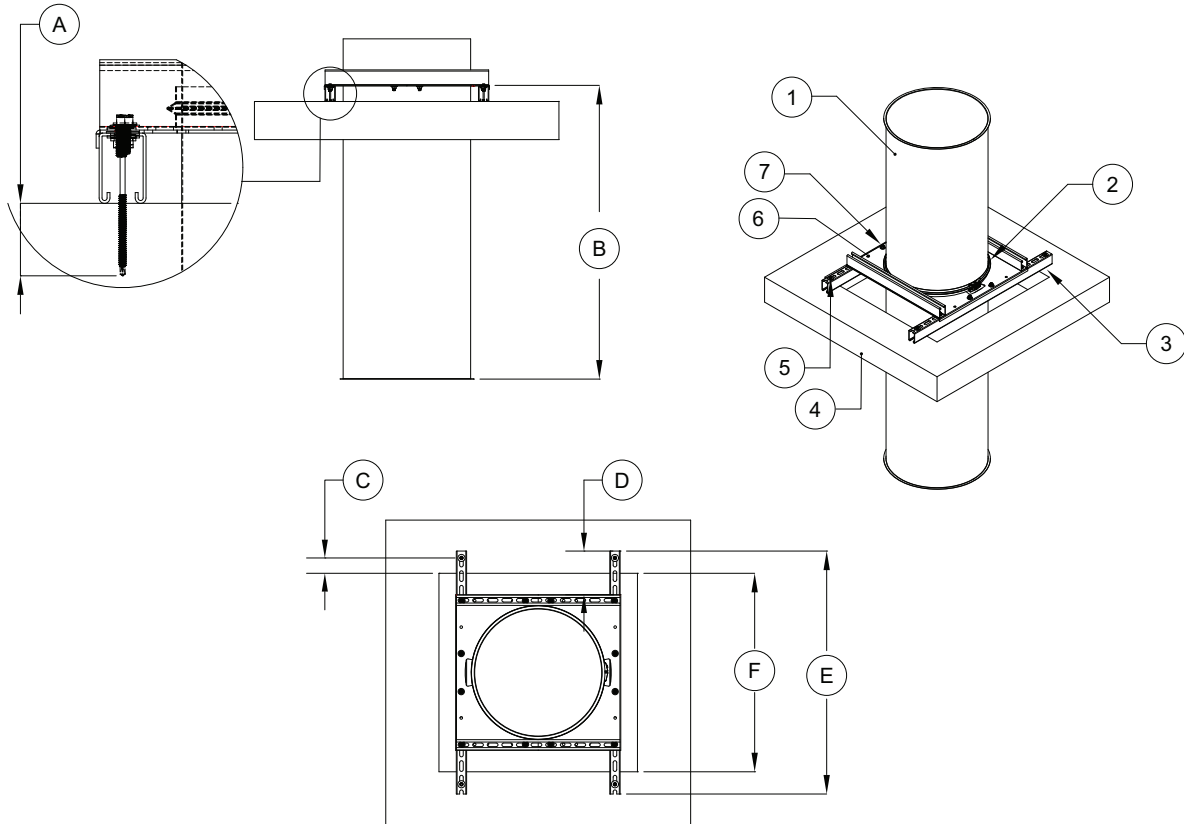
Figure 32 - Duct Ceiling Support



\* Supports must be rotated so that all-thread is attached directly to the ceiling. **DO NOT ATTACH ALL-THREAD FROM ONE UNISTRUT TO ANOTHER.**

**IMPORTANT:** Vertical supports shown in this manual (Figure 29 through Figure 33) are recommended. Supports by others must be approved by the Manufacturer and AHJ. Support spacing must be as stated in this manual.

**Figure 33 - Chase Floor Support**



- 1. Single Wall Duct.
- 2. Single Wall V-band.
- 3. B12 Strut.
- 4. Substrate.
- 5. Substrate Fastener, refer to **Table 12**.
- 6. Vertical Support Plate.
- 7. 3/8" Hardware.
- A. Minimum Thread Penetration, refer to **Table 12**.
- B. Vertical Support Spacing, refer to **Table 12**.
- C. Minimum Edge Distance, refer to **Table 12**.
- D. 5" Maximum Distance.
- E. 60" Maximum Distance.

**Table 12 - Substrate Hardware**

Decking Material	Hardware	Minimum Thread Penetration	Minimum Edge Distance
Wood - Minimum G.42	Zinc Plated Steel Hex Head Lag Screw 3/8" x 2-1/2" with 3/8" washer	2"	1-1/2"
Concrete - 2500 Minimum PSI	Hilti Kwik Bolt - 3/8" Diameter TZ Expansion Anchor with 3/8" washer	2-5/16"	3"
Steel Roof Truss	Dril-Flex Self-Drilling Screws 1/4"-14 Min. 1/2" Through with 1/4" washer	12 Gauge or 1/8" Thick	3/8"

## Vertical Support & Vertical Support Spacing

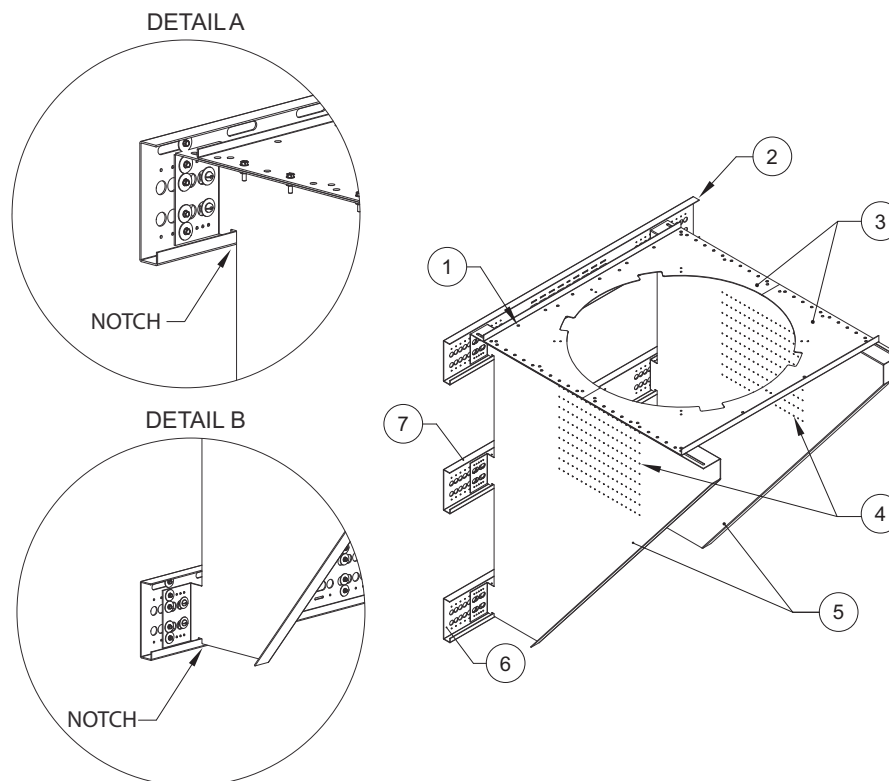
Supply duct system(s) require supports along vertical runs. There are multiple vertical supports used for duct system(s). Each support assembly is designed for a specific type of installation. Review installation site before selecting supports. There are three different types of hardware supplied depending on the type of wall that the duct are being supported on. There are three types of wall construction; gypsum with wooden studs, gypsum with 25 gauge steel studs and concrete/masonry. Each wall construction type requires different hardware to be used when installing the support assembly. Refer to **Table 13** for maximum vertical support spacing. Do not exceed this listed vertical spacing.

**Table 13 - Double Wall Vertical Support Spacing**

Model	Diameter (Inches)	Vertical Wall Support Spacing (Feet)	Vertical Curb/Floor Support Spacing (Feet)
1S, 2S, 3S	5", 6", 7", 8", 10", 12", 14", 16", 18", 20", 22", 24", 26", 28", 30", 32", 34", 36"	10'	20'

**NOTE:** Figure 34 illustrates the vertical wall support kit installation. When installing side support plates, verify the support plate hook is secured into the top and bottom wall support plates.

**Figure 34 - Vertical Wall Support Kit**

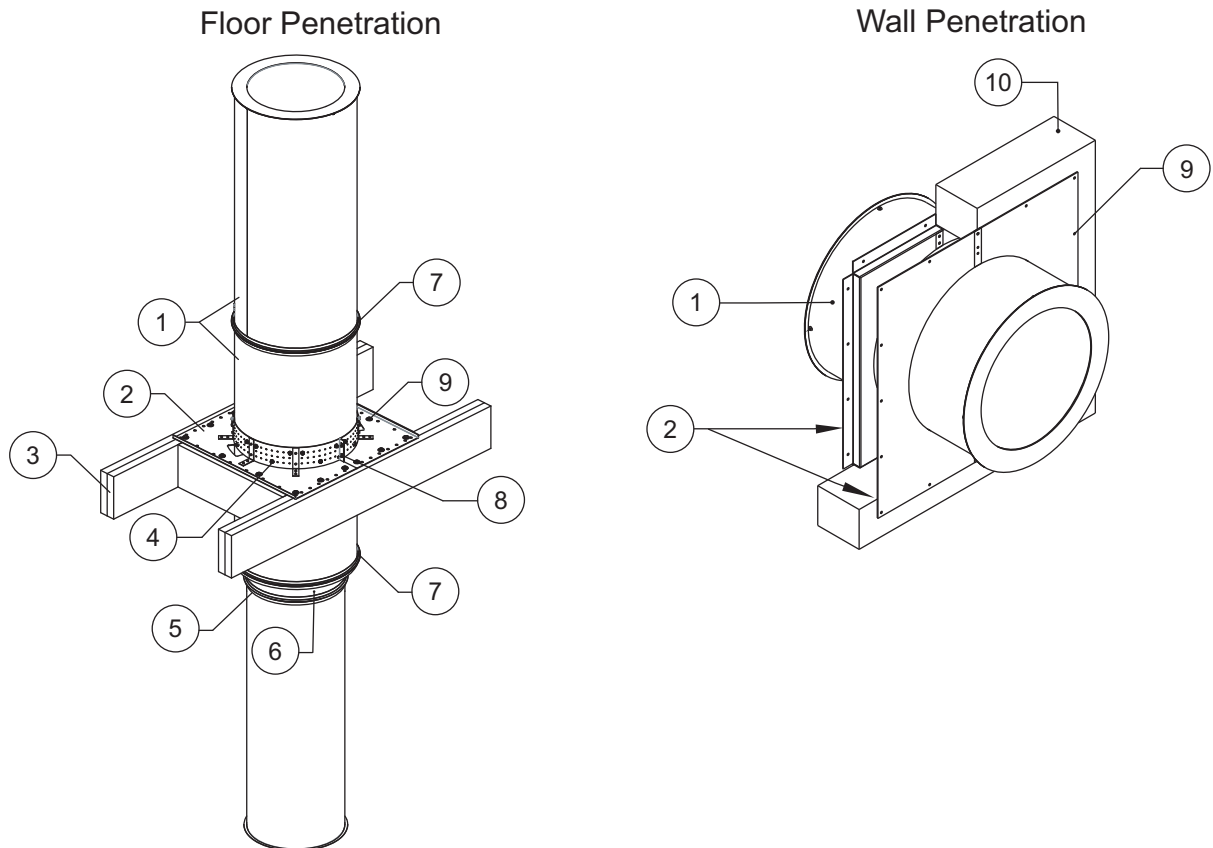


1. 5/16" Whiz Nuts and Bolts
2. Wall Support Plate (Top)
3. Flat Support Plates
4. 5/16"-18 x 1-1/2" Self Drilling Screws. Used to secure double wall duct shell.
5. Side Support Plates
6. Wall Support Plate (Bottom)
7. Wall Plate Support (Middle) - Used for addition support on 26"-36" Duct

## Double Wall Support and Guide Plate

Floor and wall support assemblies are used to support duct sections that penetrate a floor or wall. Each of these support assemblies consists of a main support. Guide plates can be used as the main support shown in **Figure 35** or used in conjunction with support assemblies. Guide plates are designed to center the duct in the floor or opening. Guide plates may be removed if a tighter clearance is desired, refer to **Table 14 on page 42** for measurements and more information.

**Figure 35 - Double Wall Through Penetration**



1. Double Wall Duct
2. Guide Plates
3. Joist
4. 5/16"-18 x 1-1/2" Self-Drilling Screws
5. Single Wall Duct Connection Shown with V-band
6. SW to DW Adapter

7. V-band
8. 1/4"-20 Whiz Nuts and Bolts
9. Substrate Hardware, refer to "**Substrate Hardware**" on page 38
10. Wall (Concrete or Wood)



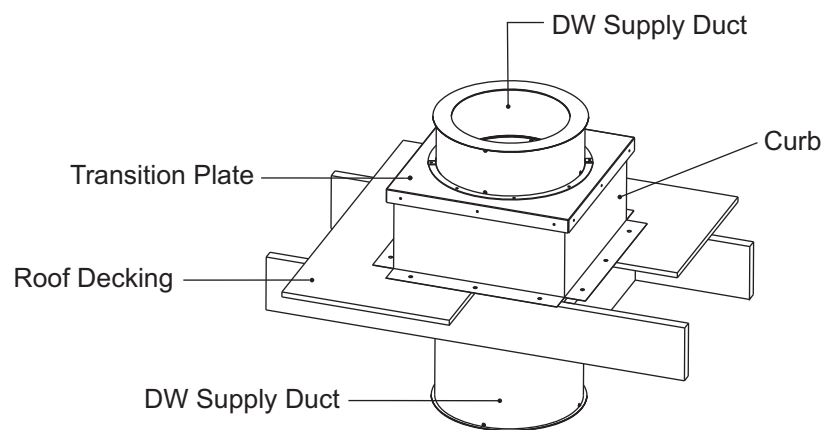
## Double Wall Vertical Thimble Curb Assembly Installation

Once the opening has been cut, refer to **Table 14 on page 42**, install the vented curb to the floor. Center the vented curb in the opening. Use the appropriate type and size fastener to secure curb. Push the insulated vent section through the top of the vented curb until the transition plate hits the top of the curb.

Install the transition plate. Secure the transition plate to the curb using 1/4"-20 x 1-1/2" zinc plated self-drilling screws where the pre-punched holes are located. Install the clearance plates on the opposite side of the roof opening. Install the bottom half of the plate first using the appropriate type and size fastener, then install the top section of the clearance plate. Fasten the two plates together using #8 x 1/2" self-drilling screws.

Apply gasket to the outside edge of the transition plate. Install the vent cap using 1/4"-20 x 2" zinc plated self-drilling screws. Inspect the thimble assembly to make sure all hardware is secure.

**Figure 36 - Thimble Assembly**

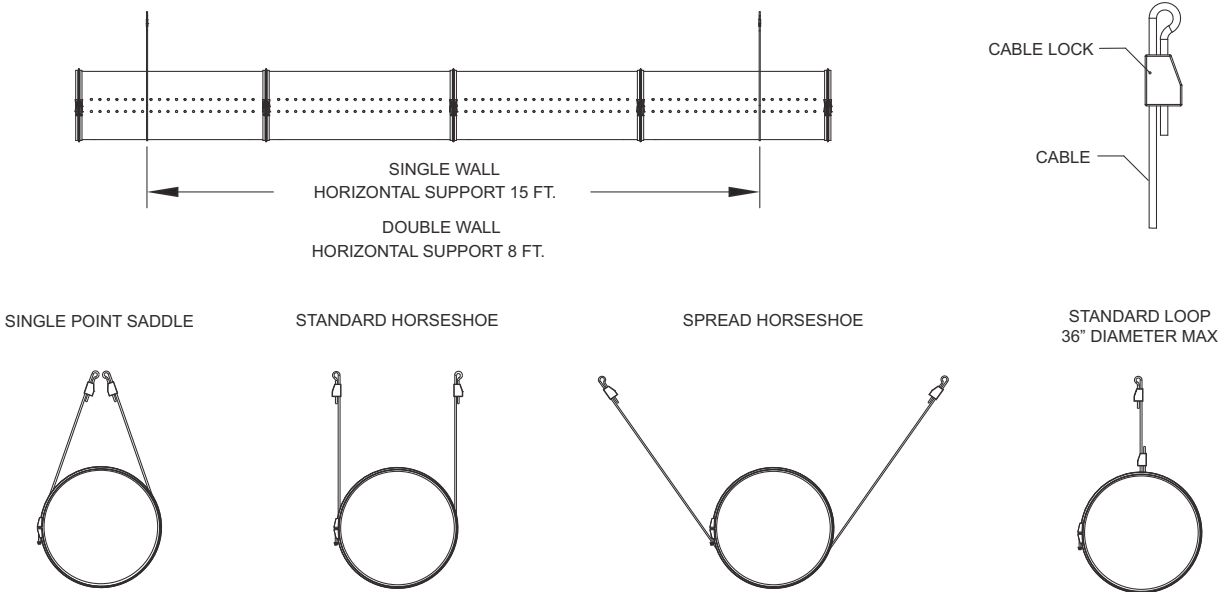


**Table 14 - Through Wall/Floor Opening**

<b>Duct Diameter</b>	<b>2S Shell Diameter</b>	<b>3S Shell Diameter</b>
5"	13-1/4"	15-1/4"
6"	14-1/4"	16-1/4"
7"	15-1/4"	17-1/4"
8"	16-1/4"	18-1/4"
10"	18-1/4"	20-1/4"
12"	20-1/4"	22-1/4"
14"	22-1/4"	24-1/4"
16"	24-1/4"	26-1/4"
18"	26-1/4"	28-1/4"
20"	28-1/4"	30-1/4"
22"	30-1/4"	32-1/4"
24"	32-1/4"	34-1/4"
26"	34-1/4"	36-1/4"
28"	36-1/4"	38-1/4"
30"	38-1/4"	40-1/4"
32"	40-1/4"	42-1/4"
34"	42-1/4"	44-1/4"
36"	44-1/4"	46-1/4"

## Horizontal Hanging Configurations

Figure 37 - Support Details



**NOTE:** When using any hanging method, if a top support (beam, joist, or other stable construction) is not available, use an eye bolt for a hanging location.

**Single Point Saddle Method:** The primary method for hanging supply duct is the single point method. The cable is looped through the top support and secured with a cable lock. The cable will be routed around the ductwork, and back to the top support. The cable is then secured with a second cable lock.

This method ensures that the working load limit of the cable lock is not adversely affected when using larger duct.

**Standard Horseshoe Method:** In this method, the cable will be looped around the upper support and secured using a cable lock. The cable is then routed under the ductwork and back up to the upper support. The cable end is secured using a second cable lock.

**Spread Horseshoe Method:** This method is similar to the standard horseshoe layout, but the cable is spread to the side. Since the cable is at an angle, there is a reduction in the working load limit. This configuration can be used when additional stability is desired. Ductwork can be hung at angles up to 60 degrees from vertical.

**Standard Loop Method:** This method, the cable is looped around the upper support and secured using a cable lock. The cable is then looped around the ductwork and secured using a second cable lock. This method is recommended for simple installations where the ductwork will not experience lateral forces or is located in locations prone to the ductwork swinging. **NOTE: The standard loop method is only permitted for use on round ductwork diameters 36" or less.**

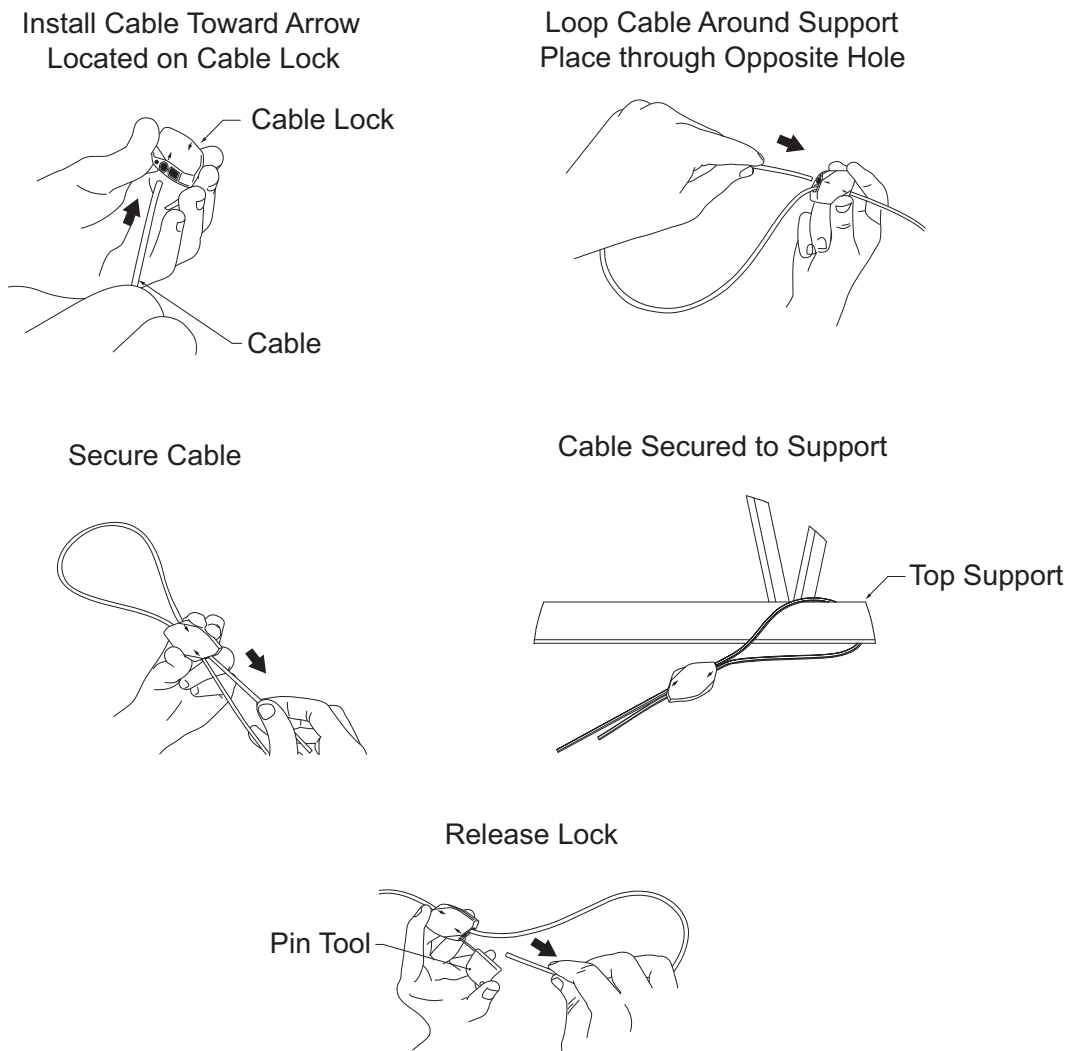
## Horizontal Support and Support Spacing

**IMPORTANT: HORIZONTAL SUPPORTS SHOWN IN THIS MANUAL ARE RECOMMENDED. SUPPORTS BY OTHERS MUST BE APPROVED BY THE MANUFACTURER AND AHJ. SUPPORT SPACING MUST BE AS STATED IN THIS MANUAL.**

Horizontal support spacing is shown in **Table 15**. When installing supports:

1. Determine the top support (beam, joist, or other stable construction) location the wire will mount around.
2. Place cable through the hole with arrow going in the same direction.
3. Loop the cable around the support, and back through the opposite hole with arrow going in the same direction.
4. Ratchet the cable until secured around the support.
5. If the cable needs to be released, use the pin tool. Verify the load is supported or removed. Insert pin tool into release hole (opposite arrow direction on cable lock). Pull cable out of the cable lock.

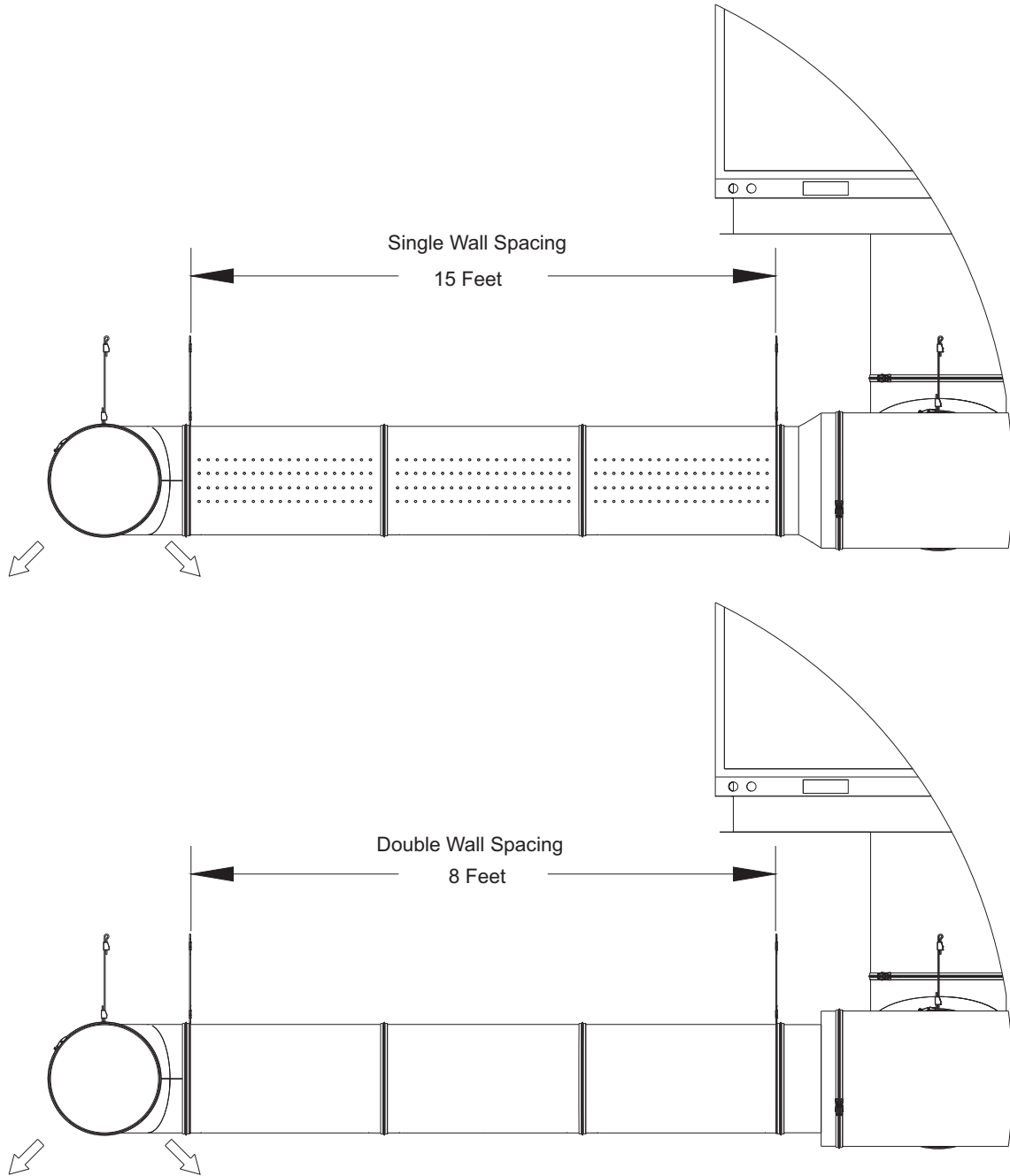
**Figure 38 - Hanging Support Installation**



**Table 15 - Horizontal Support Spacing**

Model	Diameter (Inches)	Horizontal Support Spacing (Feet)
S, S0 (HC), S90 (HC), S180 (HC)	5", 6", 7", 8", 10", 12", 14", 16", 18", 20", 22", 24", 26", 28", 30", 32", 34", 36"	15'
1S, 2S, 3S		8'

**Figure 39 - Horizontal Support Spacing Example**

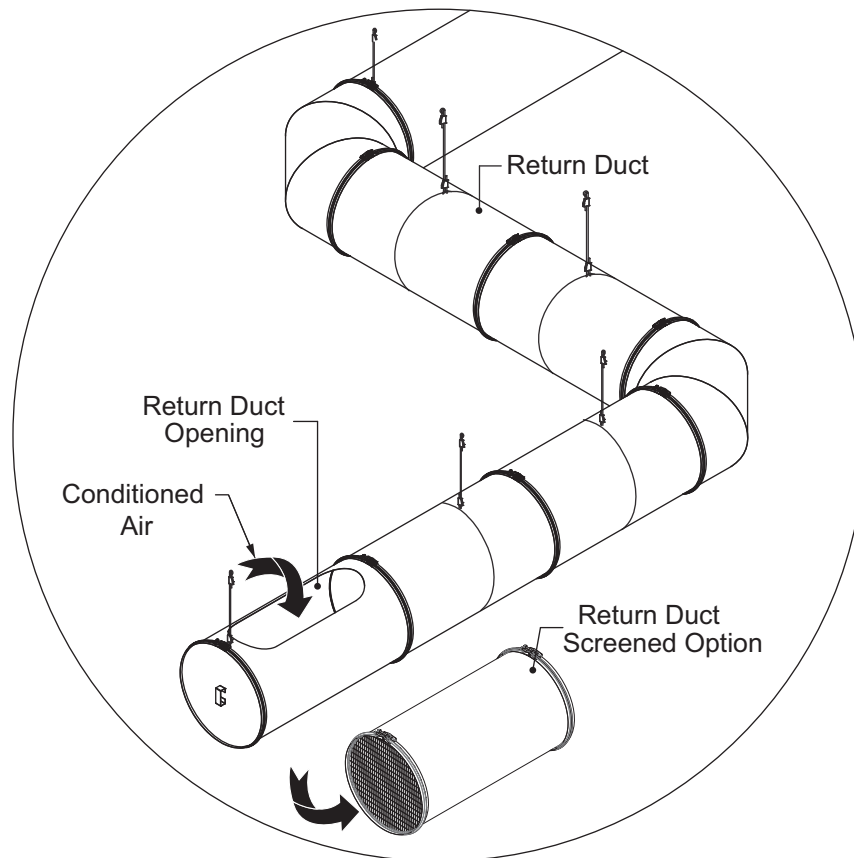


## Return Duct

**Return ducts balance airflow in an HVAC system** – The primary role of the return duct is to bring air that has been conditioned (heated/cooled exhausted air) back to the air handler. This conditioned return air will be filtered of particulates and contaminants, and redistributed into the space. The air circulation system must be balanced to ensure there is enough air entering and leaving to allow proper operation of the HVAC equipment. Correctly sized and installed return ducts will maintain good air circulation and prevent hot and cold spots. Balanced airflow prevents indoor pressure imbalance that can push conditioned air out through leaks around doors, windows, and elsewhere. This means less conditioned air and energy savings. The open return and screened return options are shown in **Figure 40**.

**Return ducts must be sized correctly** – Return ducts must be large enough to bring a sufficient amount of exhausted air back to the air handler. If the return ducts are undersized, and not enough air is brought back, the HVAC system will not be able to keep up with temperature demands. In some cases, multiple returns may be necessary to provide enough return air. Return air ducts must be placed in open areas and be free from obstruction. This will ensure that enough air is pulled back to the air handler. The velocity should not exceed a recommended 1100 feet per minute throughout the return duct run.

**Figure 40 - Return Duct**



## DI-PSP, DI-Fuse, DI-Return and Connections

### Perforated Plenums for Supply and Return Air

Drop in plenums have an important function of distributing or removing conditioned air (heated/cooled exhaust air) from a designated space. The DI-PSP (Drop-In Perforated Supply Plenum) is an insulated, two-layer perforated metal plenum that delivers unidirectional laminar airflow.

The DI-FUSE (Drop-In Diffuser) is similar to the DI-PSP, but it only has one layer of perforated metal which delivers high induction airflow.

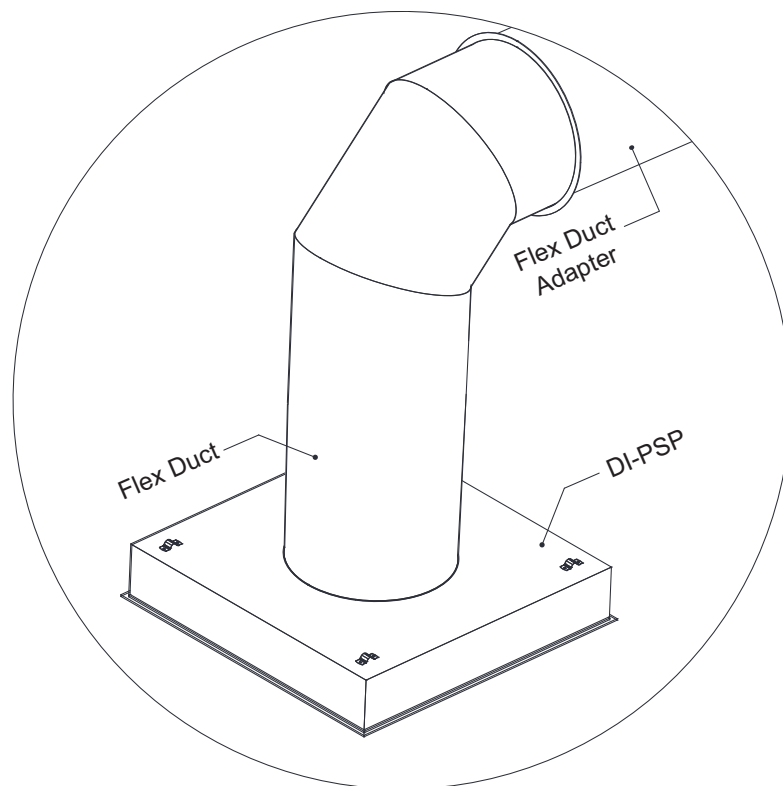
The DI-Return has one layer of perforated metal and is only used to return conditioned air back into the air handler to keep a consistent temperature in the space.

DI-PSP, DI-Flex, and DI-Return are only available in 8", 10", and 12" duct diameters. Inside the plenum is a sliding radial volume damper with an access plug in the bottom face to adjust the damper. The plenum can fit in a 24" x 24" T-Bar ceiling or can be hung from the corner brackets using wire supports. The perforated material can be taken out to clean and access the duct system.

### Connecting Drop-In Plenums

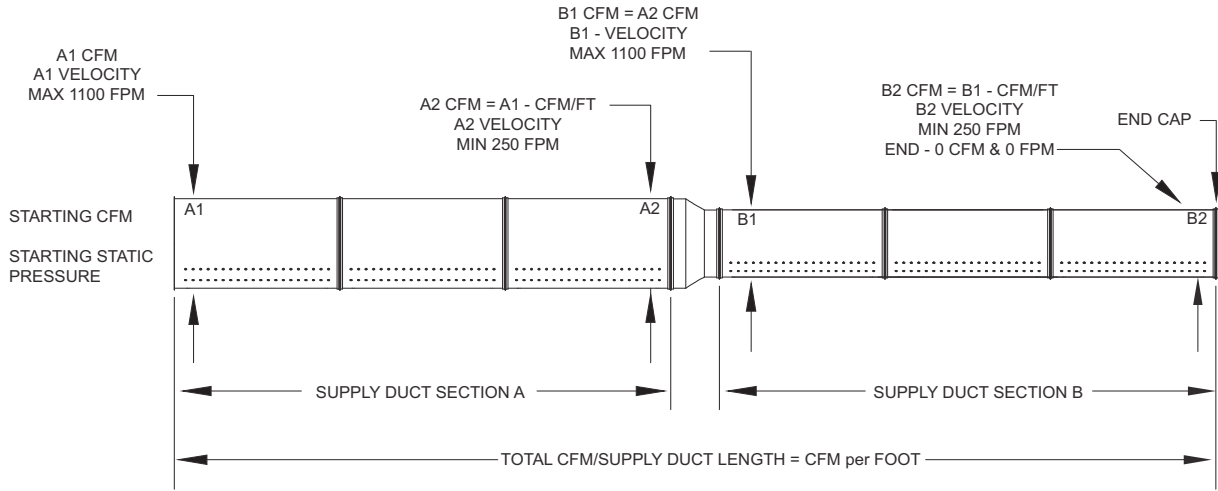
Between the drop-in plenum and the air handler is a duct system that delivers the conditioned air. The duct system can connect to the drop-in plenum with regular ductwork or flex duct. The maximum flex duct length should not exceed 6'. Installation should be as straight as possible to reduce additional static pressure.

**Figure 41 - Flexible Duct Drop-In Connection**

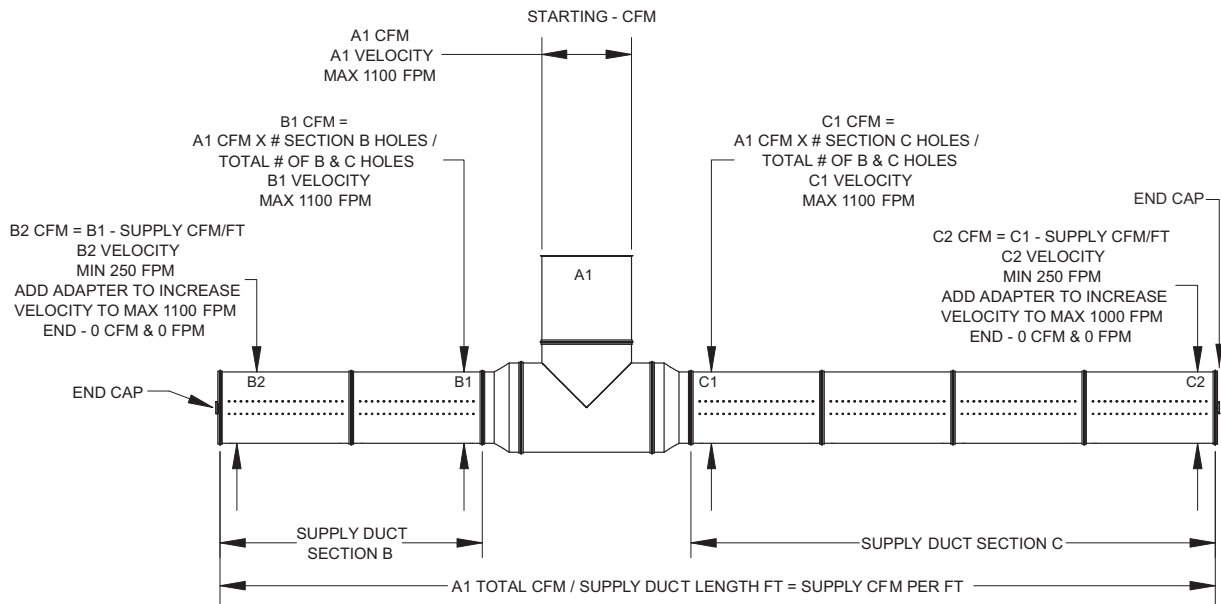


# Installation Examples

**Figure 42 - Straight Run Installation with Adapter ("S90" shown)**

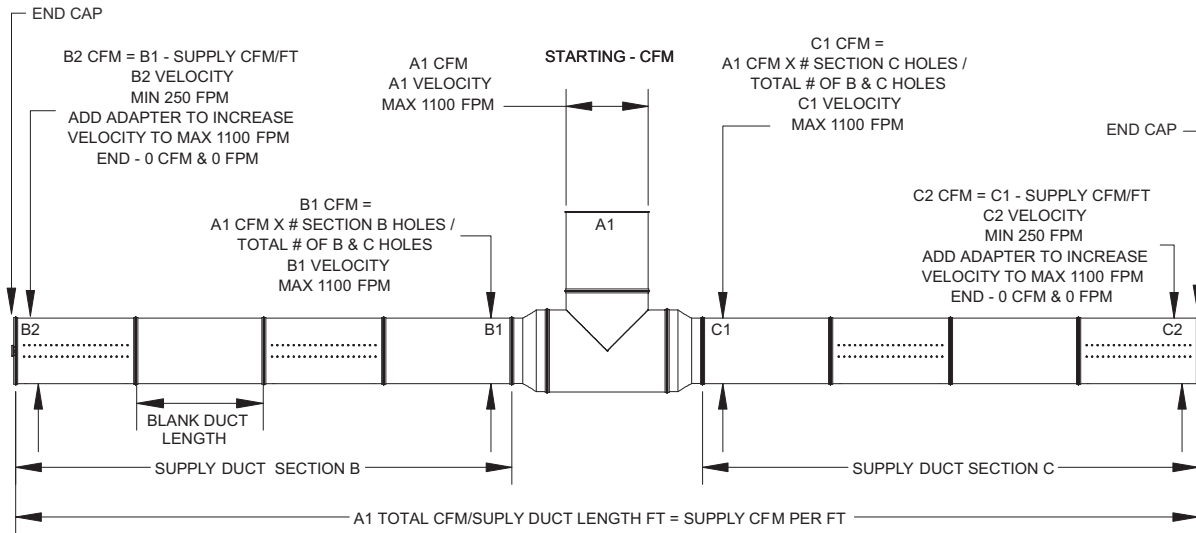


**Figure 43 - Tee Run Installation with Varying Length ("S180" shown)**

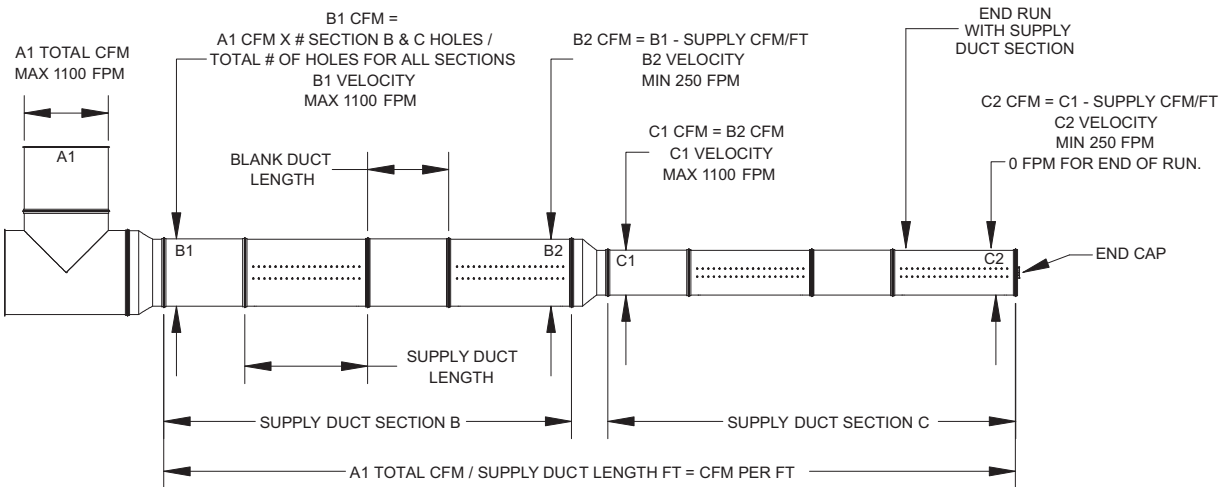




**Figure 44 - Center Tee Run Installation ("S180" shown)**



**DUCT RUN WITH ADAPTER**



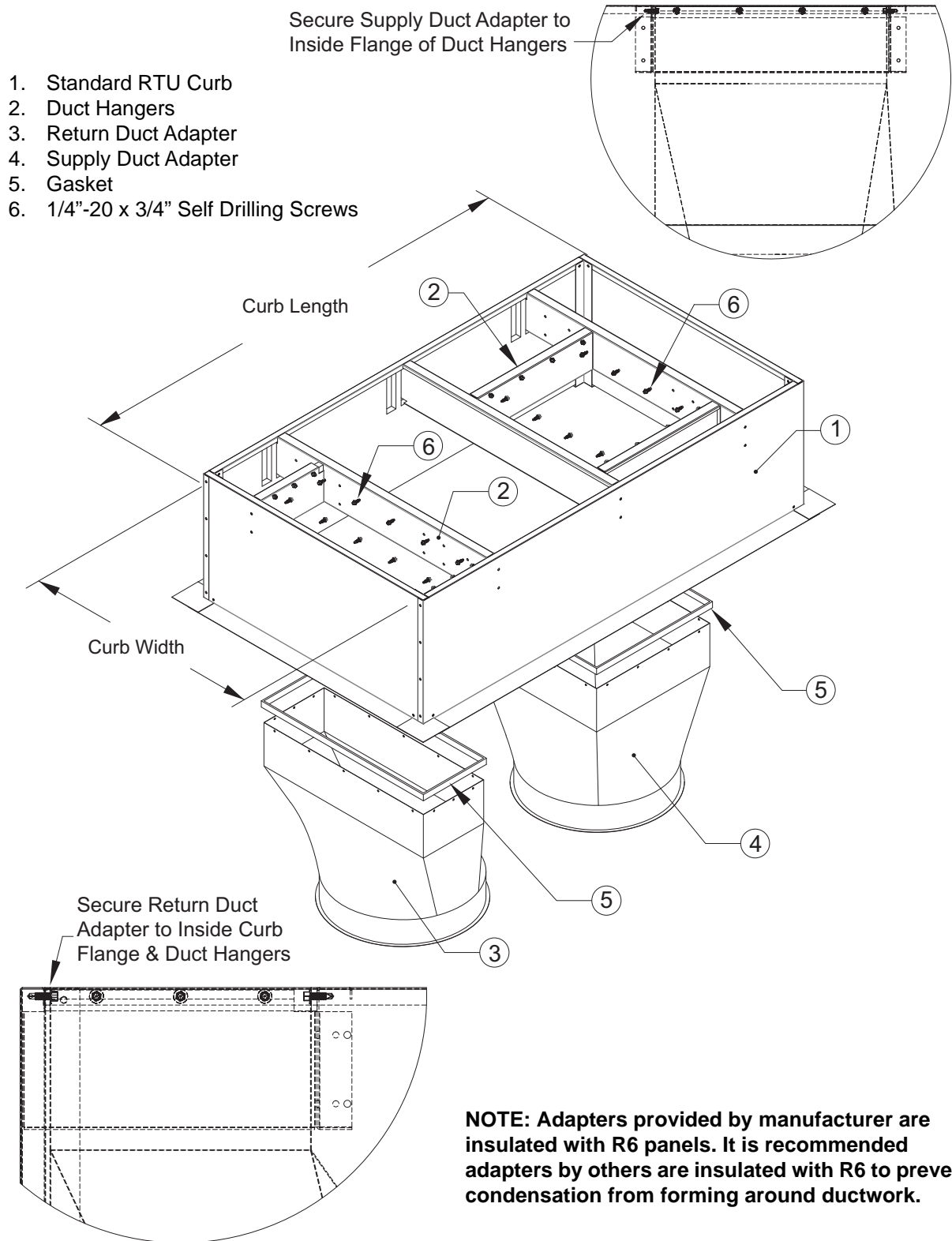
**Painting Ductwork**

Painting the supply ductwork is not required due to the stainless steel construction. However, if the duct work is painted per the end users specifications, all exterior duct labels should be removed or masked off before paint preparation. Follow the paint manufacturer's recommended instructions regarding surface preparation and paint application. **Do not use chlorinated chemicals for surface preparation of the ductwork.** The supply duct manufacturer is not responsible for any paint defects.

## Curb and Adapter

Figure 45 provides details when mounting return and supply duct adapters to an RTU curb.

Figure 45 - Curb and Adapter Details



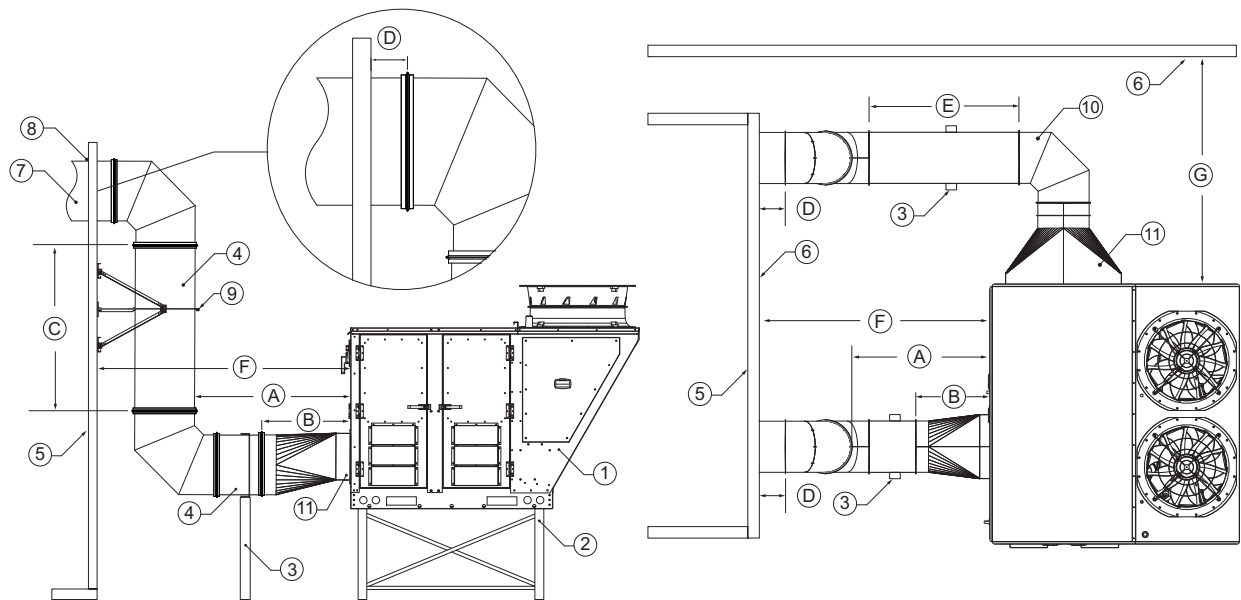
## Supply Duct Pad Mount Clearances

When a unit will be pad mounted, refer to **Figure 46** for details on installation. Always verify the distance from the wall(s) to the unit. For the supply side of the unit, there must be adequate distance between the door and duct to service components.

The minimum unsupported distance for vertical ductwork is 20'. Anything over 20' requires a wall support bracket. 40' of vertical ductwork requires two wall support brackets, 60' would require three wall supports, etc.

A saddle support is required for horizontal duct runs. Center the saddle support to prevent stress on connections. Additional saddle supports are recommended every 15'.

**Figure 46 - Supply Duct Installation Details**



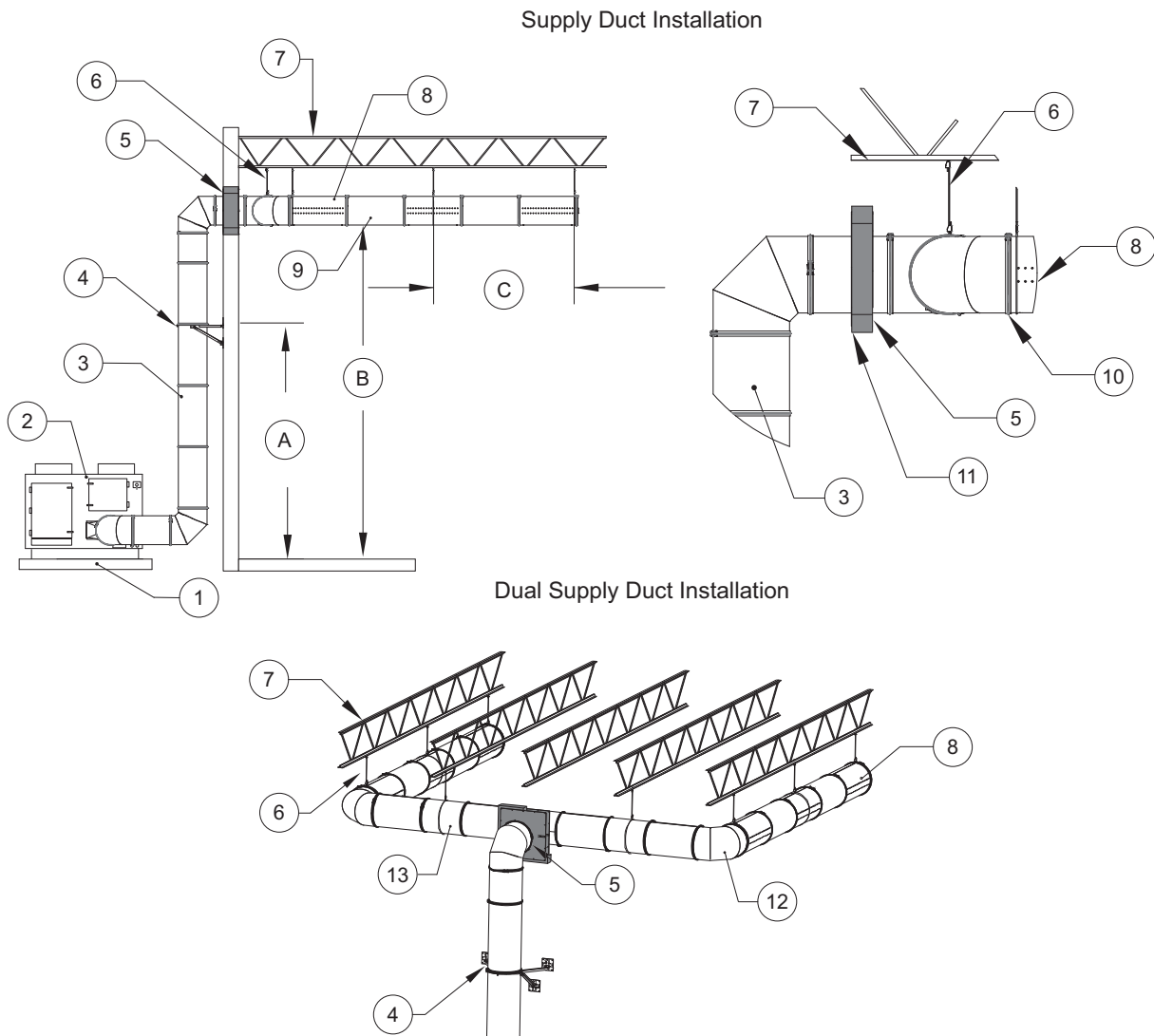
1. RTU Unit
2. RTU Stand
3. Saddle Support
4. Double Wall Supply Duct, refer to **page 5** for duct selection details
5. Interior Space
6. Exterior Wall
7. Adjustable Duct (Recommended)
8. Closure Plate (Inside/Outside)
9. Wall Support Bracket - Required for vertical ductwork lengths over 20'.
10. Double Wall Return Duct
11. Discharge Adapter - Verify the adapter is installed properly. The door above should be able to open without any interference.

- A. Door Opening Distance:
  - Size 1 = 24-1/2"
  - Size 2/3 = 25- 1/2"
  - Size 4 = 48-1/2"
- B. Adapter Height = 24"
- C. Minimum Unsupported Distance = 10'
- D. Minimum Exterior Duct Penetration = 4"
- E. Horizontal Support Recommended = Every 15' for Single Wall, every 8' for Double Wall
- F. Minimum Distance Unit to Wall (Supply Side)
  - Size 1 = 62"
  - Size 2/3 = 70"
  - Size 4 = 98"
- G. Minimum Distance Unit to Wall (Return Side)
  - Size 1 = 62"
  - Size 2/3 = 70"
  - Size 4 = 98"

## Supply Duct Assemblies

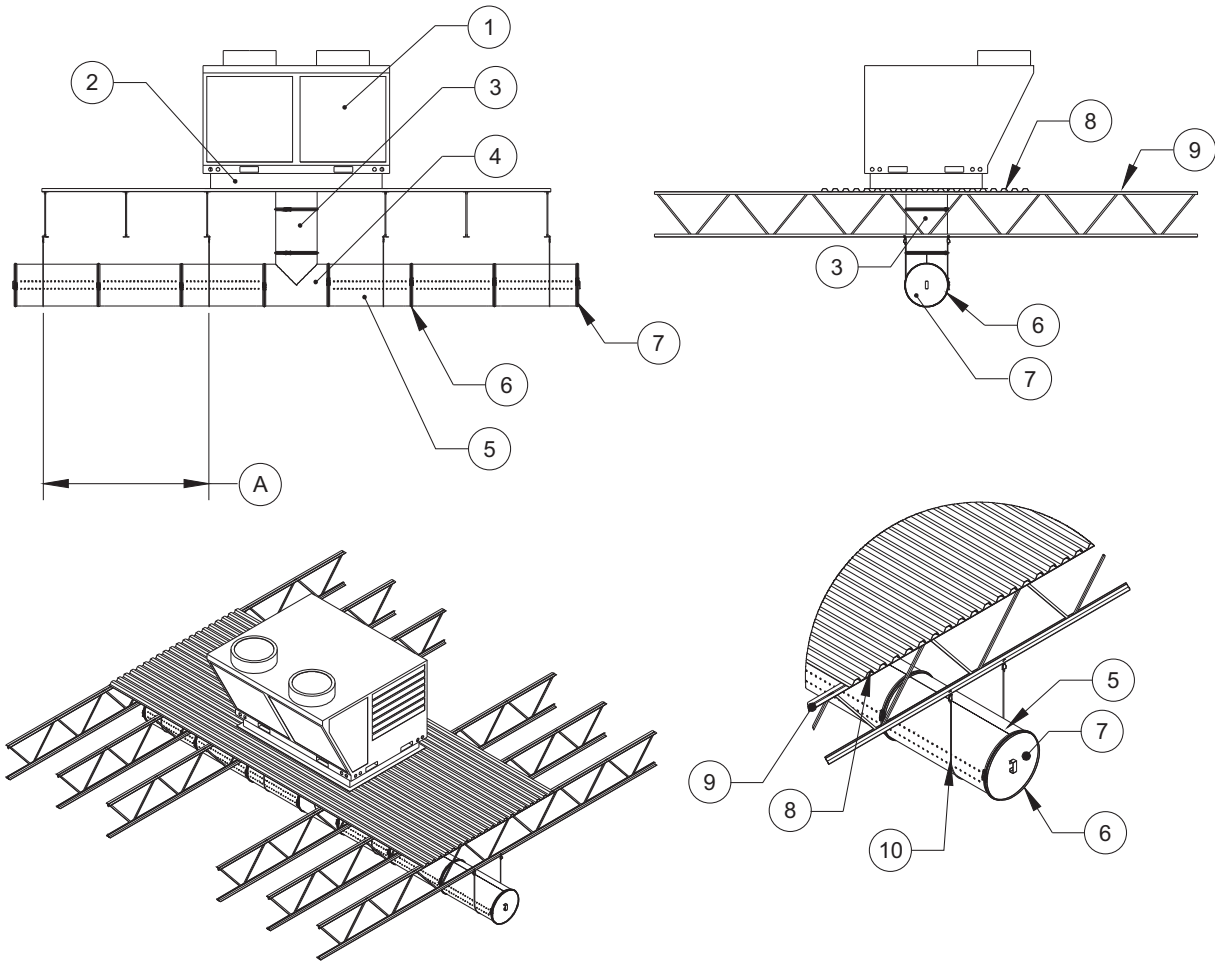
Figure 47 through Figure 51 provide useful information on the installation of supply duct systems. Each installation is specific to the application and the job site. If you encounter a situation not covered by this illustration, refer to the guide or consult the factory.

**Figure 47 - Pad Installation**



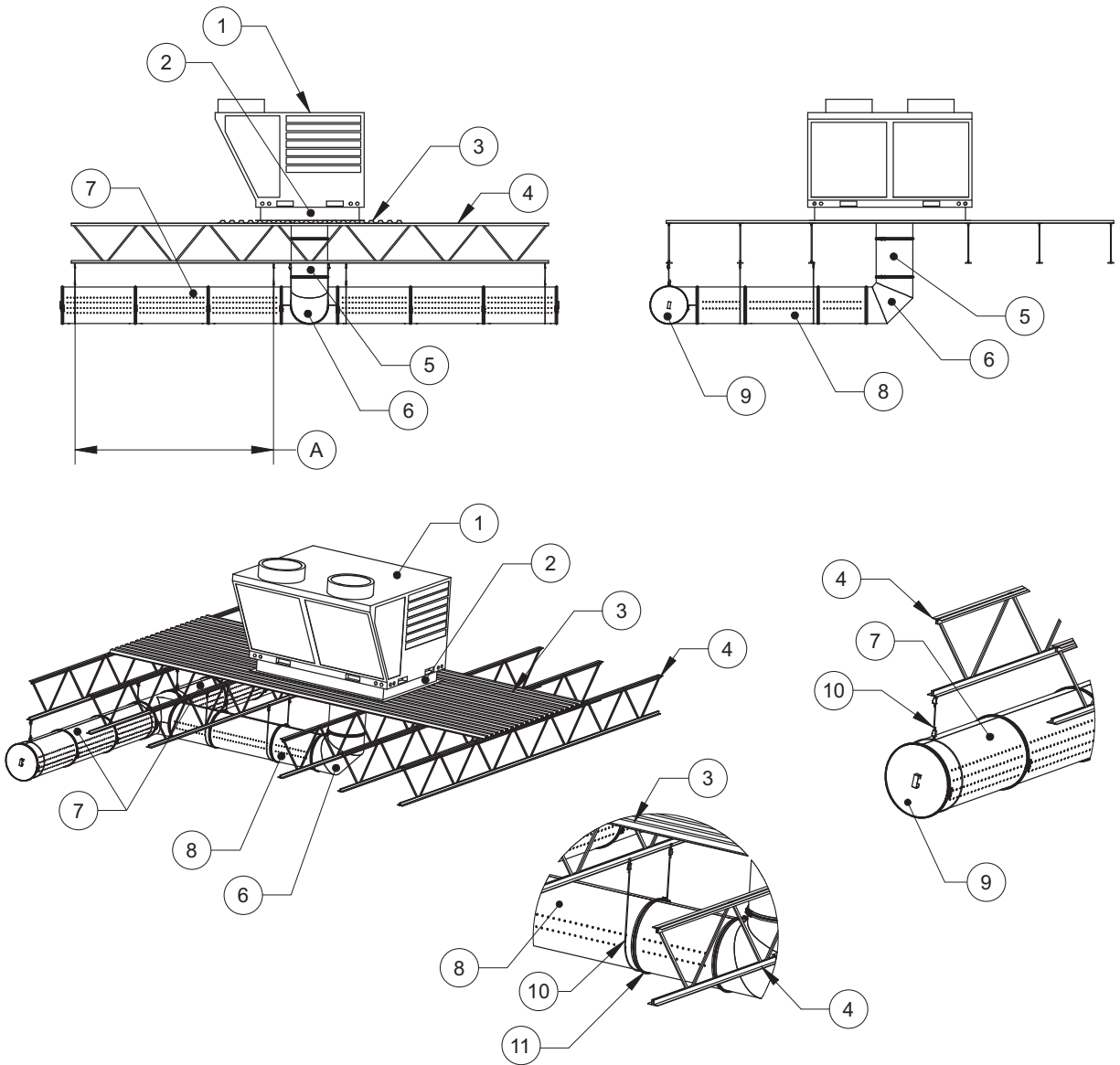
- |  |  |
|--|--|
| 1. Concrete Pad  | 9. Supply Duct Blank, see <b>page 5</b> for duct selection details |
| 2. HVAC Unit   | 10. V-band   |
| 3. Double Wall Supply Duct, see <b>page 5</b> for duct selection details | 11. Wall Opening Covers  |
| 4. Wall Support  | 12. Supply Run #1  |
| 5. Wall Penetration  | 13. Supply Run #2  |
| 6. Cable Wire  | A. Vertical Support Spacing, see <b>page 33</b>                    |
| 7. Truss   | B. Min. Rec. Height to Bottom of Duct = 7'                         |
| 8. Supply Duct (S180 Shown)  | C. Horizontal Support Spacing, see <b>page 44</b>                  |

**Figure 48 - Roof Top Installation #1**



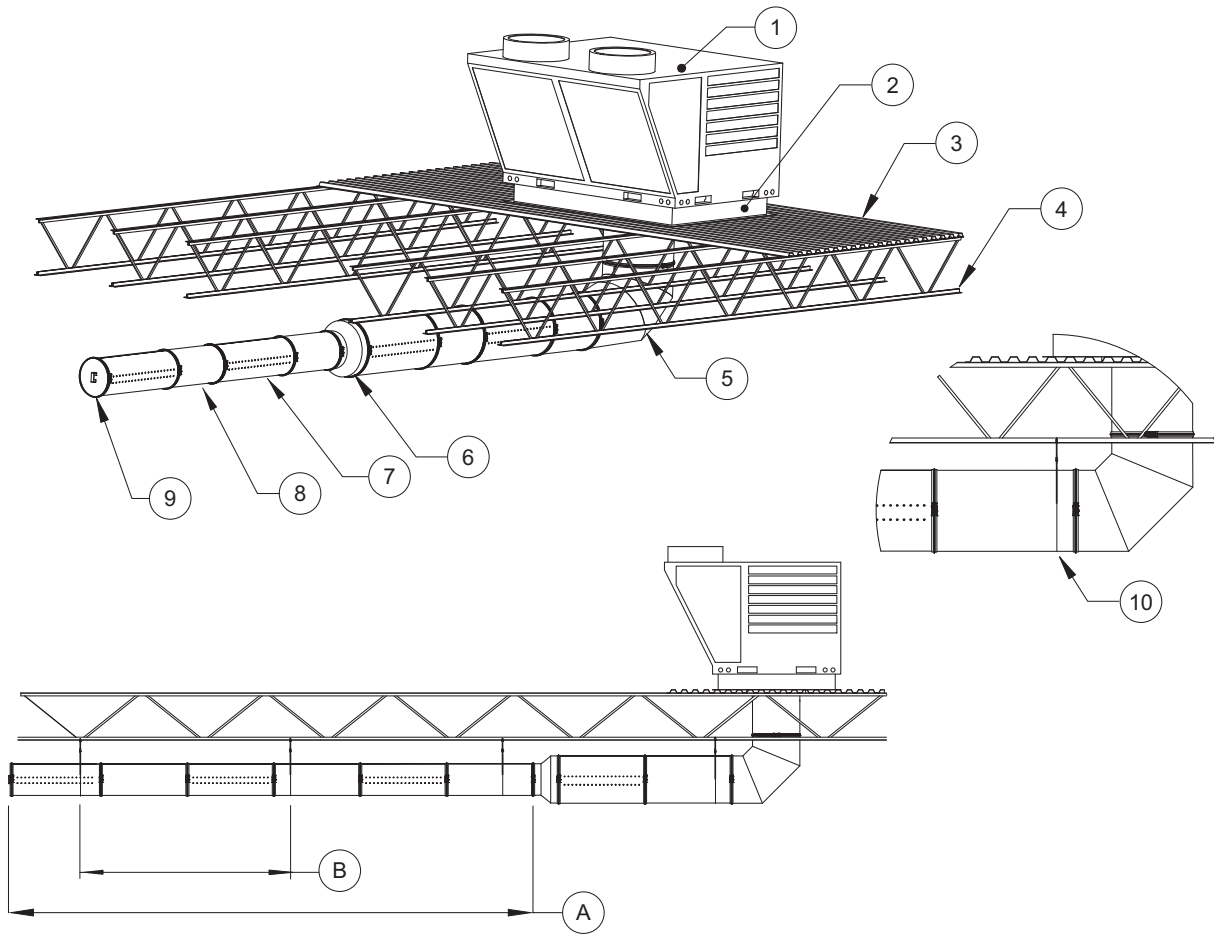
- |                             |   |
|-----------------------------|---|
| 1. HVAC Unit                | 7. Access Door                                    |
| 2. Roof Curb                | 8. Roof Deck                                      |
| 3. Supply Duct Blank        | 9. Truss  |
| 4. Supply Duct Tee          | 10. Cable Wire                                    |
| 5. Supply Duct (S180 Shown) | A. Horizontal Support Spacing, see <b>page 44</b> |
| 6. V-band                   |   |

Figure 49 - Roof Top Installation #2



- |                           |   |
|---------------------------|---|
| 1. HVAC Unit              | 8. Supply Duct (S180 Shown)                       |
| 2. Roof Curb              | 9. Access Door                                    |
| 3. Roof Deck              | 10. Cable Wire                                    |
| 4. Truss                  | 11. V-band  |
| 5. Supply Duct Blank      | A. Horizontal Support Spacing, see <b>page 44</b> |
| 6. Supply Duct Elbow      |   |
| 7. Supply Duct (S0 Shown) |   |

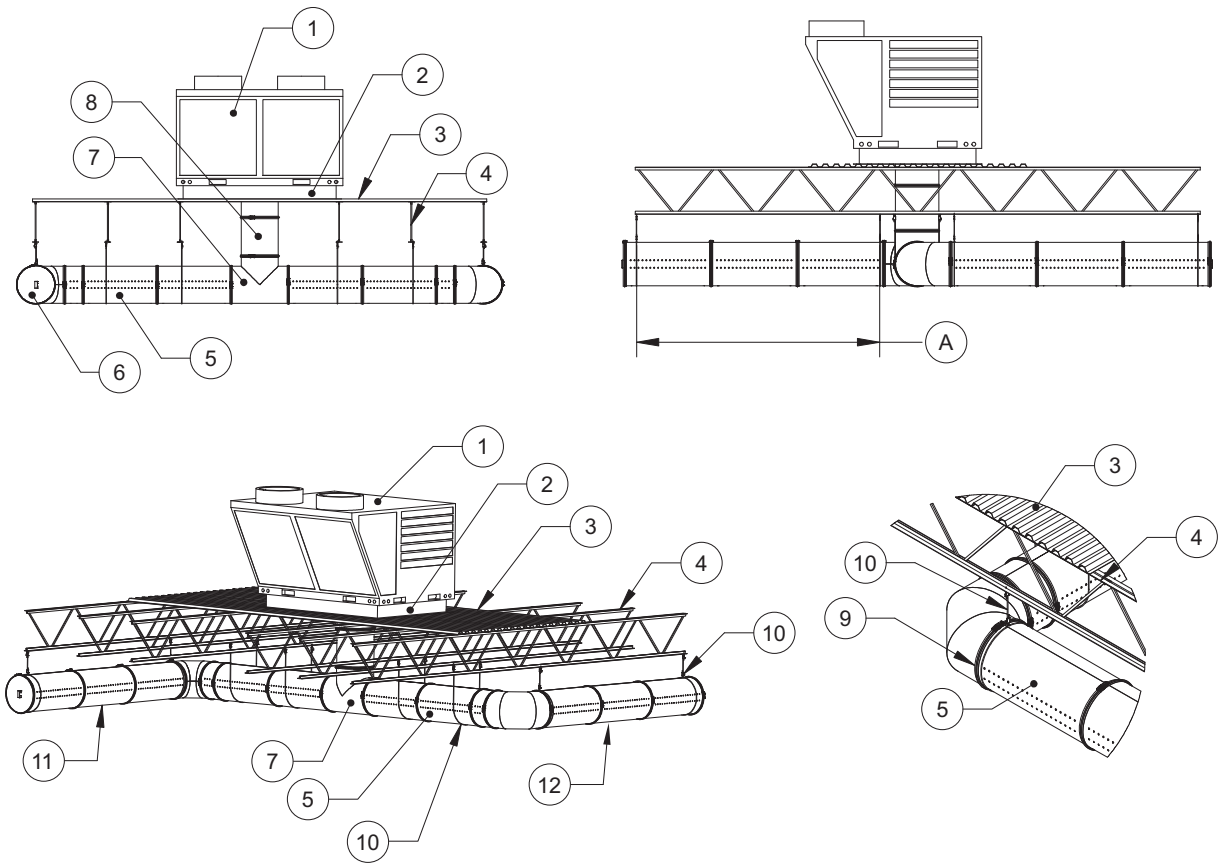
**Figure 50 - Roof Top Installation #3**



- |                             |  |
|-----------------------------|--|
| 1. HVAC Unit                | 8. Supply Duct Blank   |
| 2. Roof Curb                | 9. Access Door   |
| 3. Roof Deck                | 10. Cable Wire   |
| 4. Truss                    | A. Do not use adapters at the end of the run unless there are more than 6 full lengths of straight sections, regardless of the velocity. |
| 5. Supply Duct 90°          | B. Horizontal Support Spacing, see <b>page 44</b>  |
| 6. V-band                   |  |
| 7. Supply Duct (S180 Shown) |  |

**NOTE: Supply Duct adapters are used to maintain velocity. Max = 1100 FPM, Min = 250 FPM.**

**Figure 51 - Roof Top Installation with Change in Direction**



- |                             |   |
|-----------------------------|---|
| 1. HVAC Unit                | 8. Supply Duct Blank                              |
| 2. Roof Curb                | 9. V-band   |
| 3. Roof Deck                | 10. Cable Wire                                    |
| 4. Truss                    | 11. Supply Run #1                                 |
| 5. Supply Duct (S180 Shown) | 12. Supply Run #2                                 |
| 6. Access Door              | A. Horizontal Support Spacing, see <b>page 44</b> |
| 7. Supply Duct Tee          |   |



## Pressure Testing per SMACNA's HVAC Air Duct Leakage

A pressure test shall be performed during initial installation by the permit holder or its testing agency using the appropriate local code testing procedure. This test must be performed as a rough inspection before being covered, concealed, insulated, or wrapped before final installation to the exhaust fan, kitchen exhaust hood, or other equipment.

All single and double wall joint connections have been tested to Seal Class A, Leakage Class 1 specifications per SMACNA's HVAC Air Duct Leakage Test Manual. In the absence of local code testing procedures, use SMACNA's HVAC Air Duct Leakage Test Manual for inspection and testing guidelines.

**NOTE: If the duct system is modified or altered, the entire system will require re-testing.**

## Test and Balance

Air diffusion perforated supply duct systems are designed to replace traditional HVAC supply duct systems using vents, diffusers, and registers. Unlike traditional supply duct systems, the input air is diffused through a series of holes along the entire length of the system, this allows precise control of air diffusion and throw. It is important that the input CFM and Static Pressure (SP) are verified and match the design CFM and SP. Failure to do so may result in drafts, cold spots, and heat stratification associated with traditional duct systems.

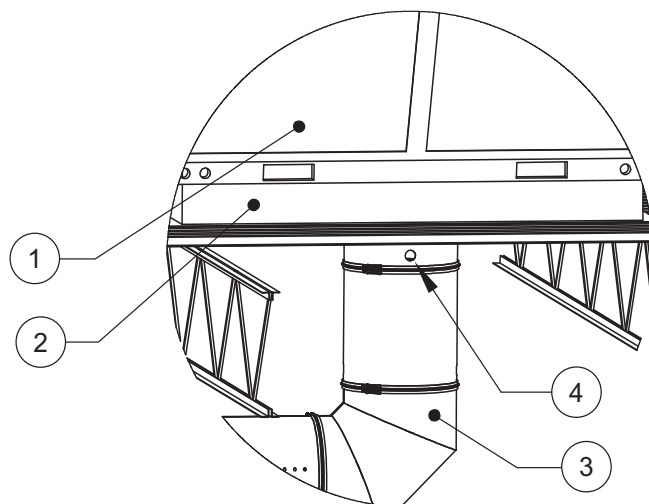
To verify the input CFM and SP, drill a hole in the supply duct system as close to the fan as possible to attain the "measured SP", see **Figure 52**. If the "actual CFM" is not within 10 percent of the design, adjustments must be made to the fan and/or system. To increase the output CFM, increase the fan speed. To decrease the output CFM, decrease the fan speed. The supply duct system should be properly sized and installed in accordance with the manufactures specifications and local code requirements.

### Formula to Calculate Actual CFM

- Actual CFM = Design CFM / Square Root (Design Pressure/Measured Pressure)
- Example: Design CFM = 7800. Design Static Pressure = 2" w.c. Measured Static Pressure = 2.4" w.c.  
 $7800 / \text{Square Root } (2/2.4) = 8545 \text{ CFM}$

**Figure 52 - Duct Testing**

1. HVAC Unit
2. Roof Curb
3. Supply Duct
4. Test Port - Once Test and Balance is complete, seal the drilled out hole.



## Supply Duct Weights

The average weight of duct, per foot of length, can be calculated using the following formulas below. Duct design should provide adequate support to ensure duct components are not overloaded.

The “L” value in the formulas below represent the total length in inches. The “D” value in the formulas below represent the inner duct diameter in inches.

### Single Wall Supply Duct

#### **24-Gauge Duct Weight (Diameters 5” – 24”)**

- The following formula can be used to approximate the weight of total lengths of duct for 24-gauge duct.  
 $(.0218 \times "L" \times "D")$

**Example: A total length of duct is 25 ft long, 14” diameter  $(.0218 \times (25' \times 12'') \times 14'') = 92 \text{ LBS}$**

#### **20-Gauge Duct Weight (Diameters 26” – 36”)**

- The following formula can be used to approximate the weight of total lengths of duct for 20-gauge duct.  
 $(.0327 \times "L" \times "D")$

**Example: A total length of duct is 25 ft long, 14” diameter  $(.0327 \times (25' \times 12'') \times 14'') = 137 \text{ LBS}$**

### Double Wall Supply Duct

#### **DW-1S Duct Weight:**

- The following formula can be used to approximate the weight of total length of DW-1S double wall supply duct (diameters 5” – 24”).

$$\text{Inner Shell} + \text{Outer Shell} + \text{Insulation} = (.0218 * L * D) + [.0218 * L * (D+2)] + [.007 * L * (D+1)]$$

- The following formula can be used to approximate the weight of total length of DW-1S double wall supply duct (diameters 26” – 36”).

$$\text{Inner Shell} + \text{Outer Shell} + \text{Insulation} = (.0327 * L * D) + [.0218 * L * (D+2)] + [.007 * L * (D+1)]$$

#### **DW-2S Duct Weight:**

- The following formula can be used to approximate the weight of total length of DW-2S double wall supply duct (diameters 5” – 24”).

$$\text{Inner Shell} + \text{Outer Shell} + \text{Insulation} = (.0218 * L * D) + [.0218 * L * (D+4)] + [.007 * L * (D+1)]$$

- The following formula can be used to approximate the weight of total length of DW-2S double wall supply duct (diameters 26” – 36”).

$$\text{Inner Shell} + \text{Outer Shell} + \text{Insulation} = (.0327 * L * D) + [.0218 * L * (D+4)] + [.007 * L * (D+1)]$$

#### **DW-3S Duct Weight:**

- The following formula can be used to approximate the weight of total length of DW-3S double wall supply duct (diameters 5” – 24”).

$$\text{Inner Shell} + \text{Outer Shell} + \text{Insulation} = (.0218 * L * D) + [.0218 * L * (D+6)] + [.007 * L * (D+1)]$$

- The following formula can be used to approximate the weight of total length of DW-3S double wall supply duct (diameters 26” – 36”).

$$\text{Inner Shell} + \text{Outer Shell} + \text{Insulation} = (.0327 * L * D) + [.0218 * L * (D+6)] + [.007 * L * (D+1)]$$

### **Double Wall Supply Duct Example Weight Calculations:**

- Duct system: DW-3S, 14” inner duct, 25’ long. Using the DW-3S formula above.

$$(.0218 * (25' * 12'') * 14) + [.0218 * (25' * 12'') * (14+6)] + [.007 * (25' * 12'') * (14+1)] = 253.86 \text{ LBS}$$

- Duct system: DW-3S, 36” inner duct, 25’ long. Using the DW-3S formula above.

$$(.0327 * (25' * 12'') * 36) + [.0218 * (25' * 12'') * (36+6)] + [.007 * (25' * 12'') * (36+1)] = 705.54 \text{ LBS}$$



