

Commercial Hoods
Installation, Operation, and Maintenance Manual

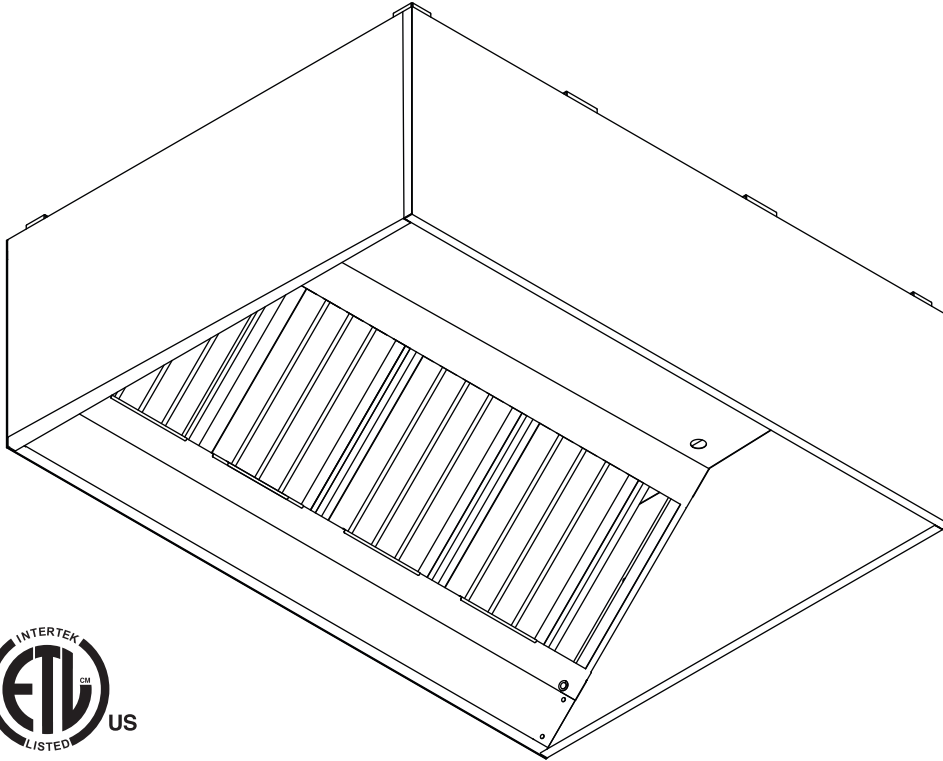

RECEIVING AND INSPECTION

Check for any signs of damage upon receipt, and if found, report it immediately to the carrier. Check that all items are accounted for and free of damage.

WARNING!!

Installation of this package should only be performed by a qualified professional who has read and understands these instructions and is familiar with proper safety precautions. Improper installation poses serious risk of injury due to electric shock, contact with rotating equipment, and other potential hazards. Read this manual thoroughly before installing or servicing this equipment. **ALWAYS** disconnect power prior to working on electrical equipment.

Save these instructions. This document is the property of the owner of this equipment and is required for future maintenance. Leave this document with the owner when installation or service is complete.

Table of Contents

WARRANTY	3
Certifications and Patents	3
INSTALLATION	4
Site Preparation	4
Clearance Reduction Methods	5
Installation of a Single Hood (Wall or Island)	7
Hanging Angle Assembly Instructions	9
Typical Hood Side View	10
End-To-End Hoods	11
Hanging Detail for Multiple Hood Models Hung End-to-End	11
Hood Connection Detail for Multiple Hood Models	12
Back-to-Back Hoods	13
Wall Mount Bracket for Backshelf Hoods.....	14
Guidelines for Ductwork Installation	15
Installation of Hood Accessories	16
Bolt-Together Standoff Installation	16
Single PSP/AC-PSP Installation	17
Multiple PSP/AC-PSP Installation	18
PSP/AC-PSP Attachment Brackets	20
Wrapper (Enclosure Panel) Installation	21
End Panel Installation	25
Quarter End Panel Installation	26
Insulated End Panel Installation	27
Vertical End Panel Installation	28
Backsplash Installation	29
Insulated Backsplash Installation	30
Pizza Oven Top Mount Flange Installation	31
Plate Shelf Option Installation	32
Pass-Through Option Installation	33
Continuous Capture Option	34
OPERATION	35
Performance Evaluation	35
Guidelines before Beginning	35
External Factors which may affect Hood Performance	36
Using a Shortridge Instrument	36
Calculating Make-up Air CFM	37
Calculating Exhaust Air CFM	37
Adjustments	37
Conclusion	38
Complete Equipment List for Performance Evaluations	38
TROUBLESHOOTING	39
MAINTENANCE	40
General Maintenance	40
Daily Maintenance	40
Quarterly Maintenance	40
PSP/AC-PSP Perforated Screen Cleaning and Maintenance	41
Start-Up and Maintenance Documentation	44
Job Information	44

WARRANTY

This equipment is warranted to be free from defects in materials and workmanship, under normal use and service, for a period of 2-years from date of shipment. This warranty shall not apply if:

1. The equipment is not installed by a qualified installer per the MANUFACTURER'S installation instructions shipped with the product.
2. The equipment is not installed in accordance with Federal, State, or Local codes and regulations.
3. The equipment is misused or neglected, or not maintained per the MANUFACTURER'S maintenance instructions.
4. The equipment is not installed and operated within the limitations set forth in this manual.
5. The invoice is not paid within the terms of the sales agreement.

The MANUFACTURER shall not be liable for incidental and consequential losses and damages potentially attributable to malfunctioning equipment. Should any part of the equipment prove to be defective in material or workmanship within the 2-year warranty period, upon examination by the MANUFACTURER, such part will be repaired or replaced by MANUFACTURER at no charge. The BUYER shall pay all labor costs incurred in connection with such repair or replacement. Equipment shall not be returned without MANUFACTURER'S prior authorization, and all returned equipment shall be shipped by the BUYER, freight prepaid to a destination determined by the MANUFACTURER.

NOTE: To receive warranty coverage for this product, copy and print out the "Start-Up and Maintenance Documentation" on page 44. Fill in all details required. Fax the page to 1-919-516-8710 or call 1-866-784-6900 for information on emailing forms in.

Certifications and Patents

This hood is ETL-listed to standard UL710, ULC710, and ULC-S646 when installed in accordance with these installation instructions and National Fire Protection Association Standard "NFPA 96, Standard for Ventilation Control and Fire Protection of Commercial Cooking Operations."

Approved for use in New York City per the Fire Department of New York Certificate of Approval #5804.

The dual supply plenum controlling Make-Up Air and Air Conditioned Air is covered under the following patents: System for Directing and Controlling Two Separate Streams of Air to a Kitchen: United States Patent No. 7963830 B2; Canadian Patent No. CA2820509; Patent No. CA2520330

Exhaust Hoods are covered under the following patent: Kitchen Exhaust Hood Assembly having Components secured together by Threaded Studs: Canadian Patent No. CA2520435C

INSTALLATION

It is imperative that this unit is installed and operated with the designed airflow, filters, and construction in accordance with this manual. If there are any questions about any items, please call the service department at **1-866-784-6900** for warranty and technical support issues.

WARNING: IMPROPER INSTALLATION, ADJUSTMENT, ALTERATION, SERVICE OR MAINTENANCE CAN CAUSE PROPERTY DAMAGE, INJURY, OR DEATH. READ THE INSTALLATION, OPERATION, AND MAINTENANCE INSTRUCTIONS THOROUGHLY BEFORE INSTALLING OR SERVICING THIS EQUIPMENT.

WARNING: TO REDUCE THE RISK OF FIRE, USE ONLY METAL DUCTWORK.

Site Preparation

1. Provide clearance around installation site to safely rig and lift equipment into its final position. Consider general service and installation space when locating unit.
2. Locate unit close to the space it will serve to reduce long, twisted duct runs.
3. Thoroughly review the plans and specifications of the project.
4. Determine the exact location in which the cooking hood will be installed and verify that there are no interferences that will prevent proper installation.
5. Verify that all overhead beams and angles are structurally strong enough to support the weight of the hood and hanging system. It is often necessary to strengthen existing structural beams, as they are not designed to carry the weight of a stainless-steel hood. Refer to the project submittal drawing for hood weight(s). It may also be necessary to create a support structure suspended from the ceiling joists to better align with the desired hood location.
6. Determine if adequate room is available to install the hood and all ductwork with proper clearances from combustible material. IMC, NFPA 96, and local Authorities Having Jurisdiction (AHJ) call for a minimum clearance (typically 18 inches for type 1, grease rated hoods) between the cooking hood(s), exhaust ducts, and building materials that are combustible. However, IMC and NFPA 96 outline acceptable clearance reduction methods; **most authorities accept the clearance reduction methods approved in the manufacturer's ETL listing for Type 1, grease rated hoods. See "Clearance Reduction Methods" on page 5.** It is important to check with the local AHJ to determine that the installation method is satisfactory to meet their requirements prior to installing the equipment.

FOLLOW SMACNA GUIDELINES AND RECOMMENDATIONS FOR HANGING AND INSTALLATION OF HOODS.

Clearance Reduction Methods

Clearance reduction methods have been evaluated and tested, and are certified by ETL. The method of testing was derived from UL 710 with temperature criteria taken from appropriate standards. Refer to **Figure 1** through **Figure 3** for clearance reduction details.

The hood may be installed with a 0-inch clearance to combustible materials per ETL if constructed in one of the following methods:

- 1-inch thick minimum layer of insulation of type Owens Corning Type 475 or Johns Manville Type 475 or listed kitchen exhaust duct insulation.
- 1-inch thick minimum insulated backsplash, insulation of type listed above.

To comply with the ETL certification, the cooking appliance must be located:

- At least 6-inches from the rear wall.
- At least 24-inches below the bottom edge of the hood.
- Cooking surface must not exceed temperatures above 700°F.

The hood may be installed with a 3-inch clearance to limited combustible materials per NFPA 96 if constructed in one of the following methods:

- 3-inch factory installed rear uninsulated standoff.
- 3-inch factory installed top wrapper or enclosure panel system.
- 3-inch factory installed end standoff
- Any insulated surface on the hood may be in contact with a combustible wall or structure.
- Hood surfaces perpendicular to combustible walls or structures do not need to be insulated to maintain the zero inch clearance rating.
- Only the surface of the hood against a combustible wall or structure must be insulated.

For example: On a combustible back wall, only the back of the hood needs to be insulated, even if the back wall extends beyond the back of the hood in any direction.

Figure 1 - Top Clearance Reduction Options

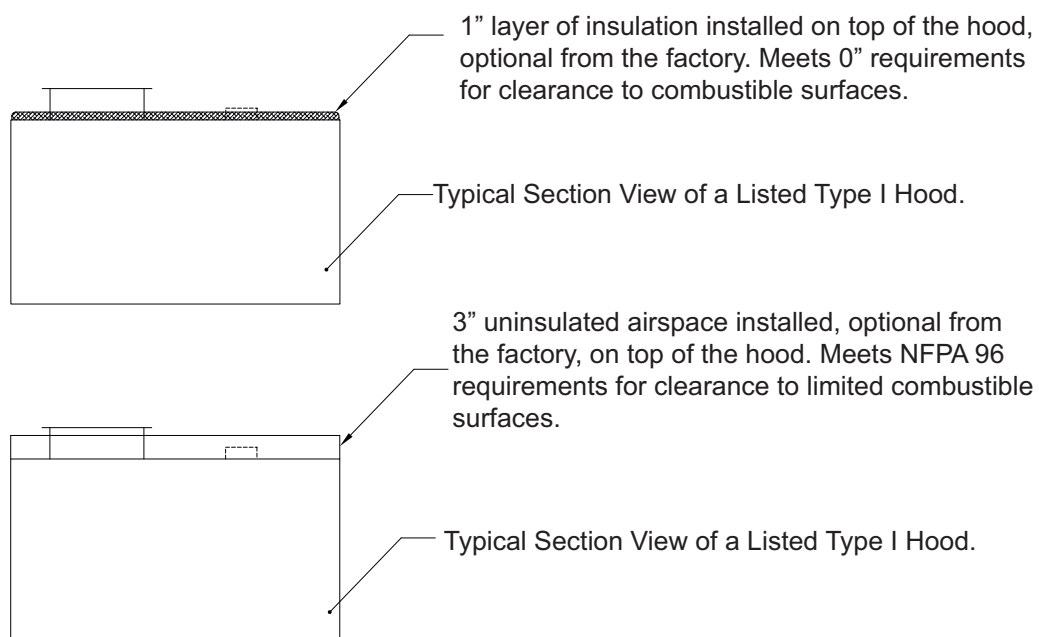

Figure 2 - End Clearance Reduction Options

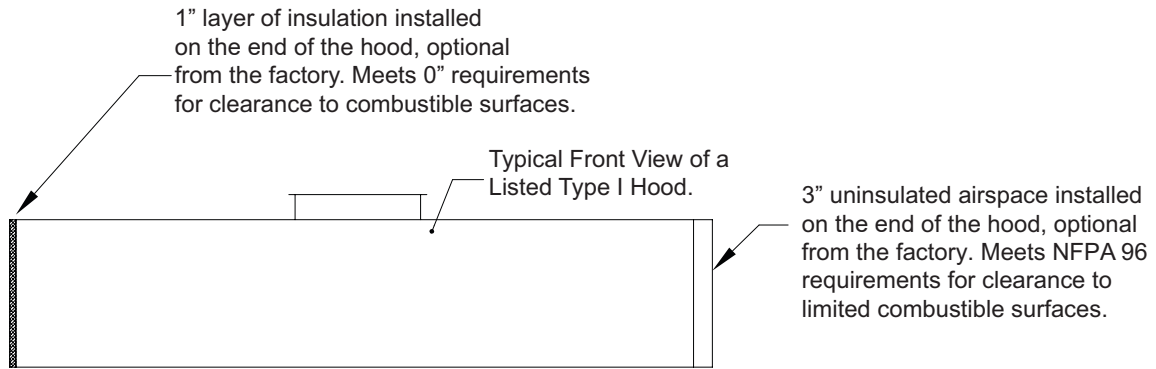
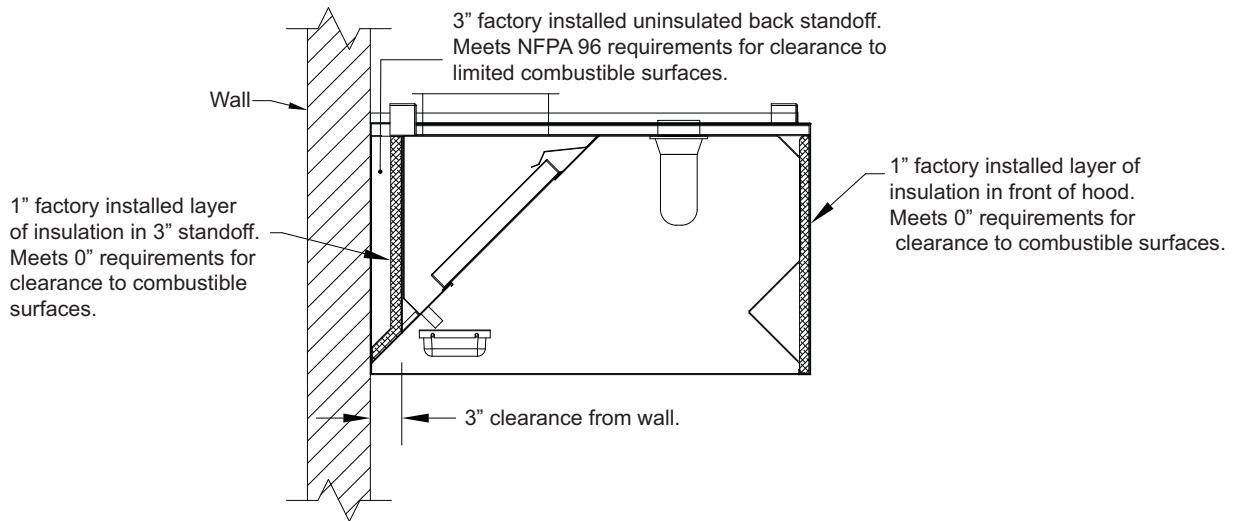

Figure 3 - Front and Back Clearance Reduction Options



Installation of a Single Hood (Wall or Island)

WARNING: VERTICALLY OR HORIZONTALLY LAGGING HOODS TO WOODEN JOISTS, TRUSSES, OR STUDS IS AN UNACCEPTABLE METHOD FOR HANGING HOODS. THIS WILL LEAD TO BOTH STRUCTURAL AND THERMAL FAILURE CAUSING INJURY AND/OR DEATH.

The following is a step-by-step procedure for installation of the ventilation hood.

Note: Report any damage to the delivering freight carrier and file a claim if appropriate.

1. Remove hood from the crate. Be very careful not to dent or scratch the outer surface. Refer to the installation drawing for typical details of the ventilation system prior to hanging the hood. Check the nameplate on the equipment to verify it meets the specifications provided by the architect and/or engineer. **If discrepancies exist, notify the manufacturer immediately.**

The nameplate will also give information regarding the following: Clearance from cooking surface to front lower edge of the hood, Minimum exhaust air flow, Maximum supply air flow (if applicable), Minimum front overhang from cooking surface, Minimum side overhang from cooking surface, Maximum cooking surface temperature, Replacing fusible links for exhaust and supply damper (if applicable), Replacing filters.

2. Determine the height at which the hood will be hung:

Canopy hoods are typically hung so that the front lower edge of the hood is within 6'-6" to 7'-0" Appliance From Floor (AFF). However, the hood should be hung so that the proper clearance from the cooking surface to the front lower edge of the hood is maintained. Refer to nameplate for clearance from cooking surface to front lower edge of hood. Exact hood hanging height should be verified with local Authorities Having Jurisdiction (AHJ).

Note: If there are wrappers (enclosure panels) with the order, measure down from the ceiling height of the wrappers. That will be the top hanging height of the hood as long as the following criteria are met: The front lower edge of the hood is within 6'-6" to 7'-0" AFF. The front lower edge of the hood is within the clearance requirement from the cooking surfaces. If the hanging height based on wrappers does not fall in this range, contact your local office.

Backshelf hoods are typically hung at the maximum height allowed from the cooking surfaces. Refer to nameplate for clearance from cooking surface to front lower edge of hood. The exact hood hanging should be verified with local AHJ.

Note: If there are wrappers with the order, measure down from the ceiling height of the wrappers. That will be the top hanging height of the hood as long as the front lower edge of the hood is within the clearance requirement from the cooking surfaces. If the hanging height based on wrappers does not fall in this range, contact your local office.

3. If the hood has a bolt-together standoff, install now. **See "Bolt-Together Standoff Installation" on page 16.**
4. If the hood has duct thermostats, install them now per the thermostat installation drawing.
5. Position hood on the floor in its approximate final position with the supply and exhaust risers on the hood located directly beneath the corresponding openings in the roof, if possible. It is advisable to finalize the location using a plumb-bob or laser. **Protect the hood when it is on the jacks to avoid dents, scratches, and other damage to the hood.**
6. Proceed to weld exhaust duct to hood while on the floor, if possible.
7. Use 1/2-inch threaded rod to hang hoods. Drill 9/16-inch holes in the structural support system or use Unistrut to line up with the welded-on angle mounting brackets on the hood. There are several types of mounting brackets depending upon the hood type; each has a pre-drilled hole. **The structural integrity of the structural support system is the responsibility of the contractor and the structural engineer.** Center hanging angles are provided on hoods 12 feet in length and longer. **Center hanging angles must be used to support the hood weight and prevent filter fitment and grease drainage issues.** Some backshelf hoods do not have hanging angles and must be anchored to a back

wall using the standing flange provided. Structural lag bolts must be used every 12-inches on center maximum and must be secured to studs behind wall. Refer to **Figure 4**.

8. The spacing on the hole for the modified support should line up with the mounting bracket on top of the hood. The top hanger should be 1/2-inch closer to the back wall than the mounting bracket on the hood to pull the hood against the wall. Refer to **Figure 5**. Some hoods are designed for island installations where a wall is not present.
9. With the hood well protected against possible scratching, raise the hood into position using high lifts or equipment jacks at each end to keep the hood level. When the hood is elevated to the proper height, install 1/2-inch threaded rod between each mounting bracket on the hood and the modified support. Secure rods with heavy duty nuts and appropriately sized fender washers above and below the hanging angle.
10. Make final adjustments as needed to ensure the hood is hung level. Maintain tension on all rods to ensure the hood weight is evenly distributed. If it is necessary to stand or work on top of the hood, use pieces of plywood to evenly distribute weight on the hood to prevent damage.
11. Brace hood to ceiling joists and wall(s), as applicable, so that the hood does not move. Secure hood to wall in a manner acceptable to the local AHJ.
12. If installing single PSP/AC-PSP to the hood, install now. **See “Single PSP/AC-PSP Installation” on page 17.**
13. If the hood has multiple Perforated Supply Plenums (PSPs) or AC-PSPs, install them now. **See “Multiple PSP/AC-PSP Installation” on page 18.**
14. Install the exhaust ductwork. The entire exhaust duct system must be continuously welded, liquid tight unless it is Listed Factory Built Grease Duct. The duct must be welded to the hood exhaust collar and the roof curb cap must be welded to the exhaust duct.
15. Install the supply ductwork. **See “Guidelines for Ductwork Installation” on page 15.**
16. If the hood is equipped with a control unit, an installation wiring diagram will be provided inside of the control unit. The jobsite electrician is responsible for making the appropriate field connections. This includes all lights and duct/hood mounted thermostats.
All field wiring on top of the hood must use high temp wire and wire nuts (black). Wiring must be routed through hard or flex conduit. Route and attach all conduit on top of, or above, structural joists (Hat Channel) on top of hood. Conduit cannot contact the surface of the hood ceiling.
17. If the hood is equipped with a factory pre-piped fire suppression system, a certified fire system installer is responsible for completing the field hookup, testing, and certifying the system in accordance with the manufacturer’s specifications and the local fire codes. If the hood is not pre-piped, a certified fire system installer is responsible for installing, testing and certifying the system in accordance with the manufacturer’s specifications and the local fire codes.
18. If the hood is equipped with wrappers (enclosure panels), end panels and/or back-splash panels, install them now. **Refer to page 21 through page 30.**
19. Caulk the lower edge of the hood where it meets the wall. This does not apply to hoods installed in island configurations.
20. Install light bulbs, light globes, and grease filters in the hood.
21. Install grease cups in the brackets/slots provided.
22. Use a stainless-steel polish to clean the hood of dust or dirt acquired in transit.
23. It is recommended that the protective plastic sheeting remains on the installed hood until construction is complete, so as to avoid any damage to the equipment.

WARNING: NEVER PUNCTURE THE HOOD GREASE CONTAINMENT AREA TO HANG HOOD OR TO HANG ITEMS FROM HOOD. PUNCTURING THE GREASE CONTAINMENT AREA WILL VOID WARRANTY AND LISTING ON HOOD.

Hanging Angle Assembly Instructions

WARNING: VERTICALLY OR HORIZONTALLY LAGGING HOODS TO WOODEN JOISTS, TRUSSES, OR STUDS IS AN UNACCEPTABLE METHOD FOR HANGING HOODS. THIS WILL LEAD TO BOTH STRUCTURAL AND THERMAL FAILURE CAUSING INJURY AND/OR DEATH.

- Hanging angle must be supported with 1/2"-13 TPI grade 5 (minimum) all-thread.
- Use 1/2" grade 5 (minimum) steel flat washers and 1/2"-13 TPI grade 5 (minimum) hex nuts to install hanging angles and ceiling anchor points. Refer to **Figure 4** for details.
- Must use doubled hex nut configuration beneath hood hanging angles and above ceiling anchors (single hex nut beneath hanging angle is only acceptable for full length and PSP hanging angle types).
- Maintain 1/4" of exposed threads beneath bottom hex nut.
- Torque all hex nuts to 57 ft-lbs.

Figure 4 - Hanging Angle Assembly Details

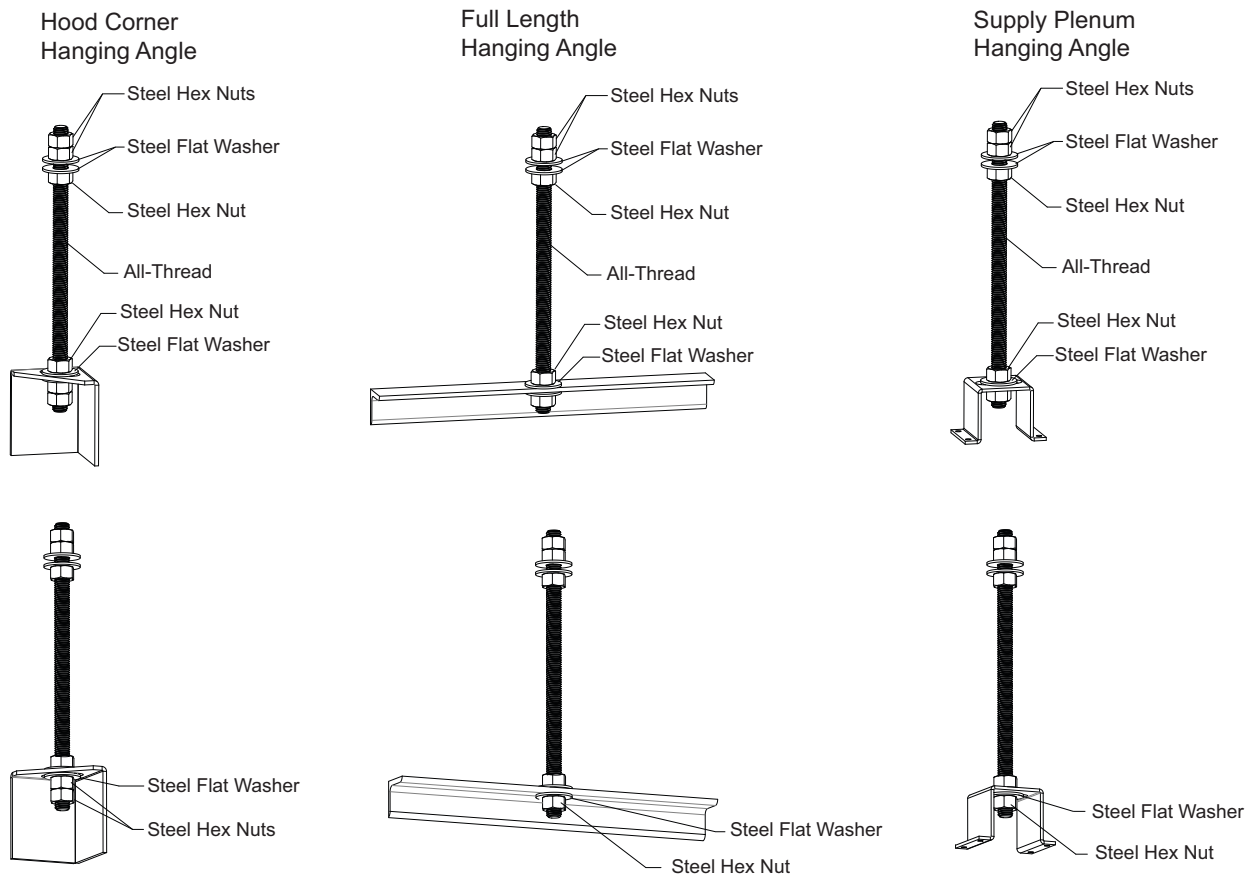

Typical Hood Side View

Refer to **Figure 5** for side view hanging details.

- X. Distance Measured Between Center of Rear Hanging Angle to Center of Front Hanging Angle
- Y. Distance Measured from Wall to Center of Rear Hanging Angle

Figure 5 - Side View

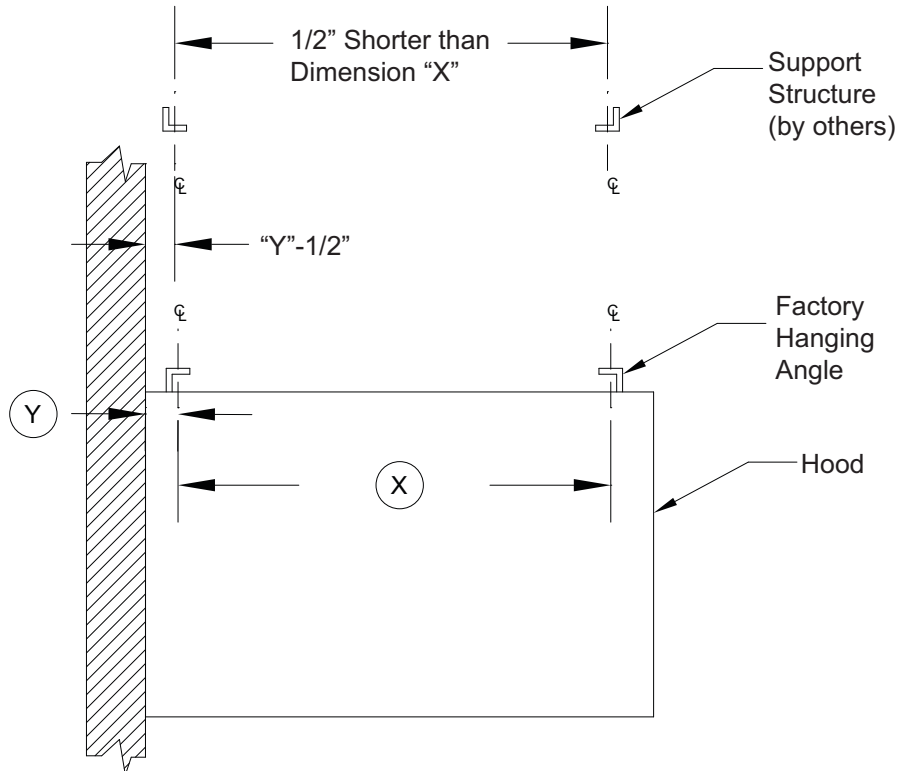

End-To-End Hoods

1. Follow steps 1 through 9 of the “Installation of a Single Hood (Wall or Island)” on page 7 for each hood.
2. Adjust tension on hanging rods to position hoods so they will fit flush with each other. Refer to **Figure 6** and **Figure 7**.
3. Bolt the top of the hoods together by sliding a threaded rod through the connection bracket slots and fastening it into position by using heavy duty nuts and washers. Refer to **Figure 8** and **Figure 9**.
4. Once all of the hoods are hung, follow steps 10 through 19 of the “Installation of a Single Hood (Wall or Island)” on page 7.

Note: Hoods having more than a 1/8” gap between them must be repositioned so that the gap between the hoods is $\leq 1/8$ ”. Run a bead $\geq 1/8$ ” of silicone sealant along the lower horizontal seam of the two hoods. Slip the U-channel trim, if applicable, over the seam as shown in Figure 6. Tape can be used to hold the U-channel in place until the silicone cures. U-channel is not required on hoods with flanged ends.

5. Run a bead of the same silicone sealant along the front vertical seam between the two hoods. Slip the T-strip trim between the hoods, if applicable. Refer to **Figure 8**. T-Strip is not required on hoods with flanged ends and fully welded, ground, and polished corners.
6. Proceed with steps 20 through 23 of the “Installation of a Single Hood (Wall or Island)” on page 7.

Hanging Detail for Multiple Hood Models Hung End-to-End

Figure 6 - Hemmed Ends

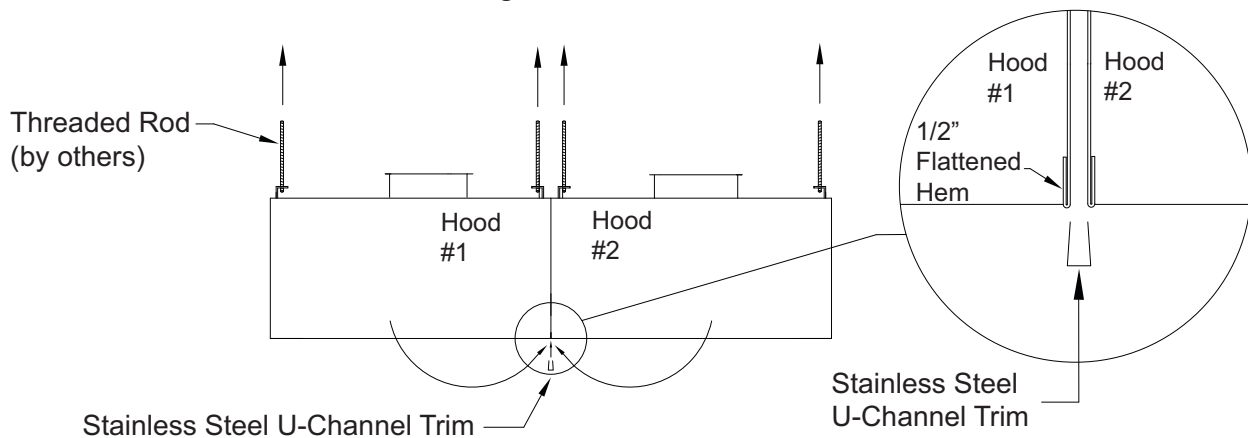
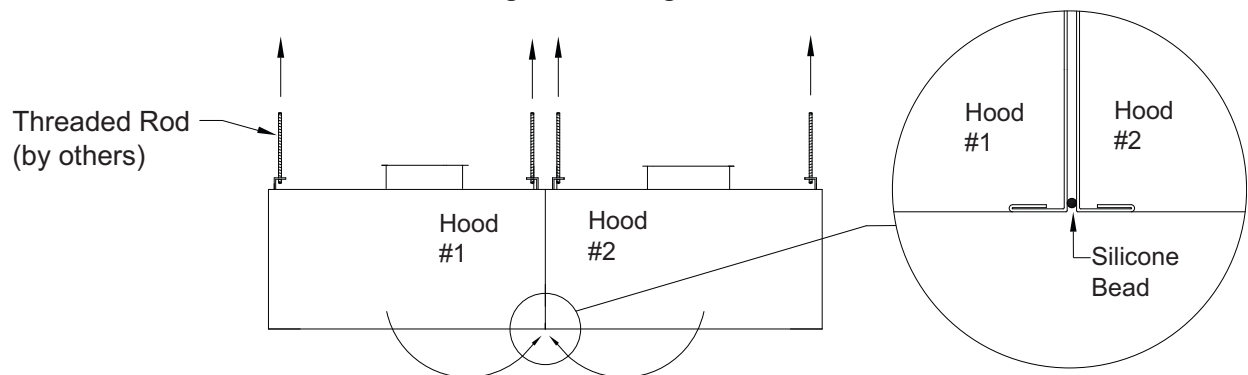

Figure 7 - Flanged Ends



Hood Connection Detail for Multiple Hood Models

Note: For Figure 8 and Figure 9, the 3/8" Nut, Fender Washer, and Threaded Rod/Bolts are provided by contractor.

Figure 8 - Hemmed Ends with Trim Strip

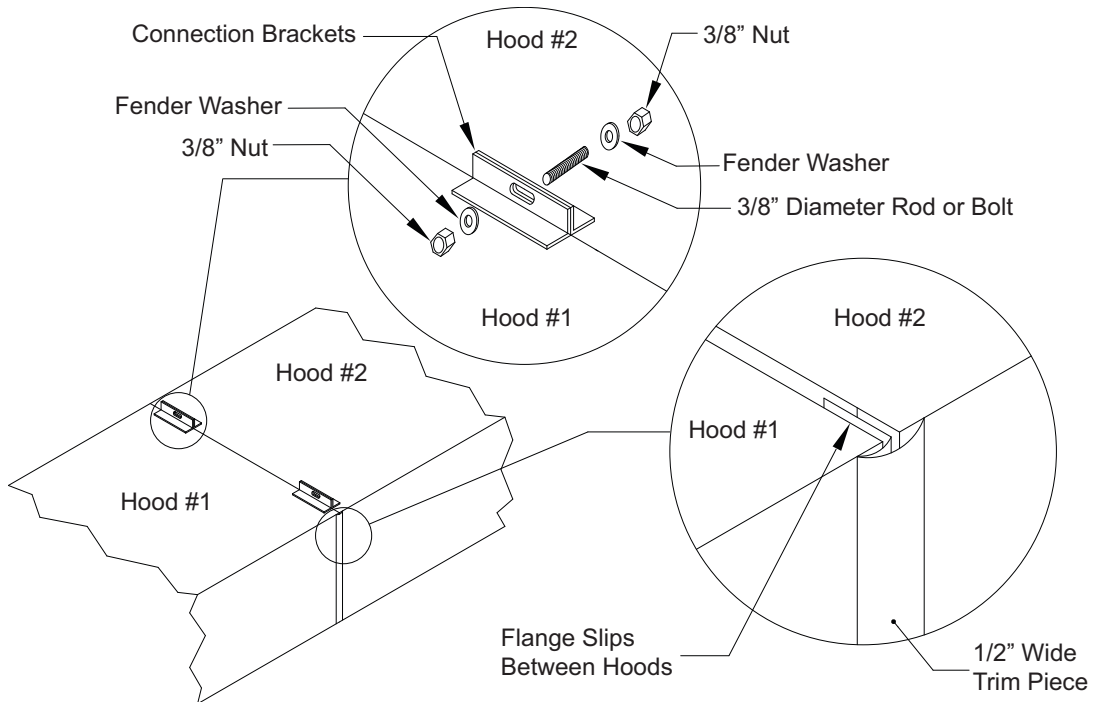

Note: For Figure 9, once the hoods have been installed, place the hoods back to back. Caulk between the edges prior to bolting them together.

Figure 9 - Flanged Ends without Trim Strip

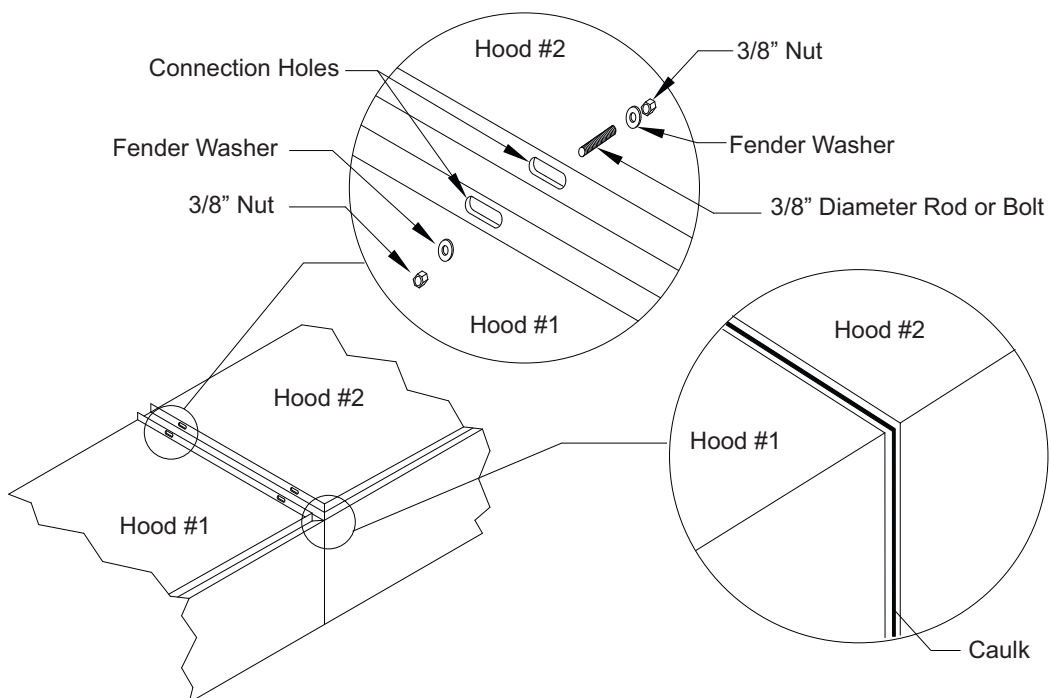

Back-to-Back Hoods

The following is a step-by-step procedure for installation of back-to-back ventilation hoods.

1. Follow steps 1 through 9 of the “**Installation of a Single Hood (Wall or Island)**” on page 7 for each hood.
2. Adjust tension on hanging rods to position hoods so they fit flush with each other. Refer to **Figure 10**.
3. Bolt the top of the hoods together by sliding a threaded rod through the connection bracket slots and fastening it into position by using heavy duty nuts and washers. Refer to **Figure 8** and **Figure 9**
4. Once all of the hoods are hung, follow steps 10 through 19 of the “**Installation of a Single Hood (Wall or Island)**” on page 7.

Note: Hoods having more than a 1/8” gap between them must be repositioned so that the gap between the hoods is $\leq 1/8$ ”. Run a bead $\geq 1/8$ ” of silicone sealant along the lower horizontal seam of the two hoods. Slip the U-channel trim, if applicable, over the seam as shown in Figure 10. Tape can be used to hold the U-channel in place until the silicone cures.

5. Run a bead of the same silicone sealant along the front vertical seam between the two hoods. Slip the T-strip trim between the hoods if applicable. Refer to **Figure 8**. **T-Strip is not required on hoods with flanged ends and fully welded, ground, and polished corners.**
6. Proceed with steps 20 through 23 of the “**Installation of a Single Hood (Wall or Island)**” on page 7.

Figure 10 - Back-to-Back Hoods

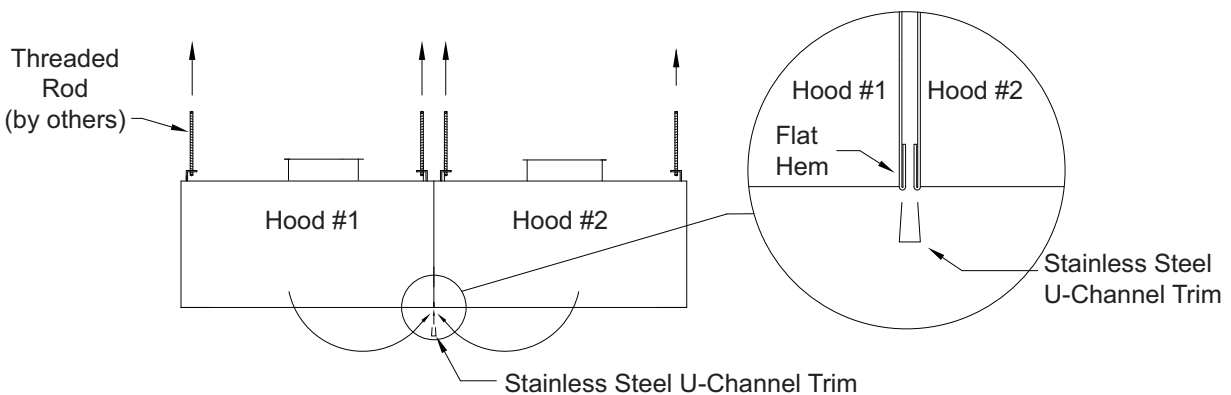

Wall Mount Bracket for Backshelf Hoods

The wall mount bracket for backshelf hoods is an accessory that is only available for hoods that are 8-feet and under. The hood must be secured to the wall using the top wall bracket and hood bottom flange. The maximum weight for the for the top shelf is 250 pounds. Refer to **Figure 11** for wall mount details.

NOTE: Wall mount bracket can only be used on non-combustible wall construction.

1. Determine mounting location of the hood:
 - For walls made of concrete/masonry, mark the location of the hood. Drill 3/16" pilot holes in the top wall bracket and hood bottom flange for fasteners.
 - For walls with metal studs, determine location of wall studs relative to hood. Drill 3/16" pilot holes in the top wall bracket and hood bottom flange for fasteners.
2. Place hood in mounting location. Secure hood with provided hardware.
3. Use the following fasteners to secure hood to wall:
 - When installing into a concrete/masonry wall, use 3/16" x 2-3/4" hardware (pn: 90950A155).
 - When installing into metal studs, use #10 x 3" self-drilling screws (pn: 92364A260).
4. Use a minimum of 1 fastener every 16" on the top wall bracket and bottom flange of the hood. For walls with metal studs, use a minimum of 1 fastener on the top wall bracket and bottom flange of the hood at each wall stud.

Figure 11 - Wall Mount

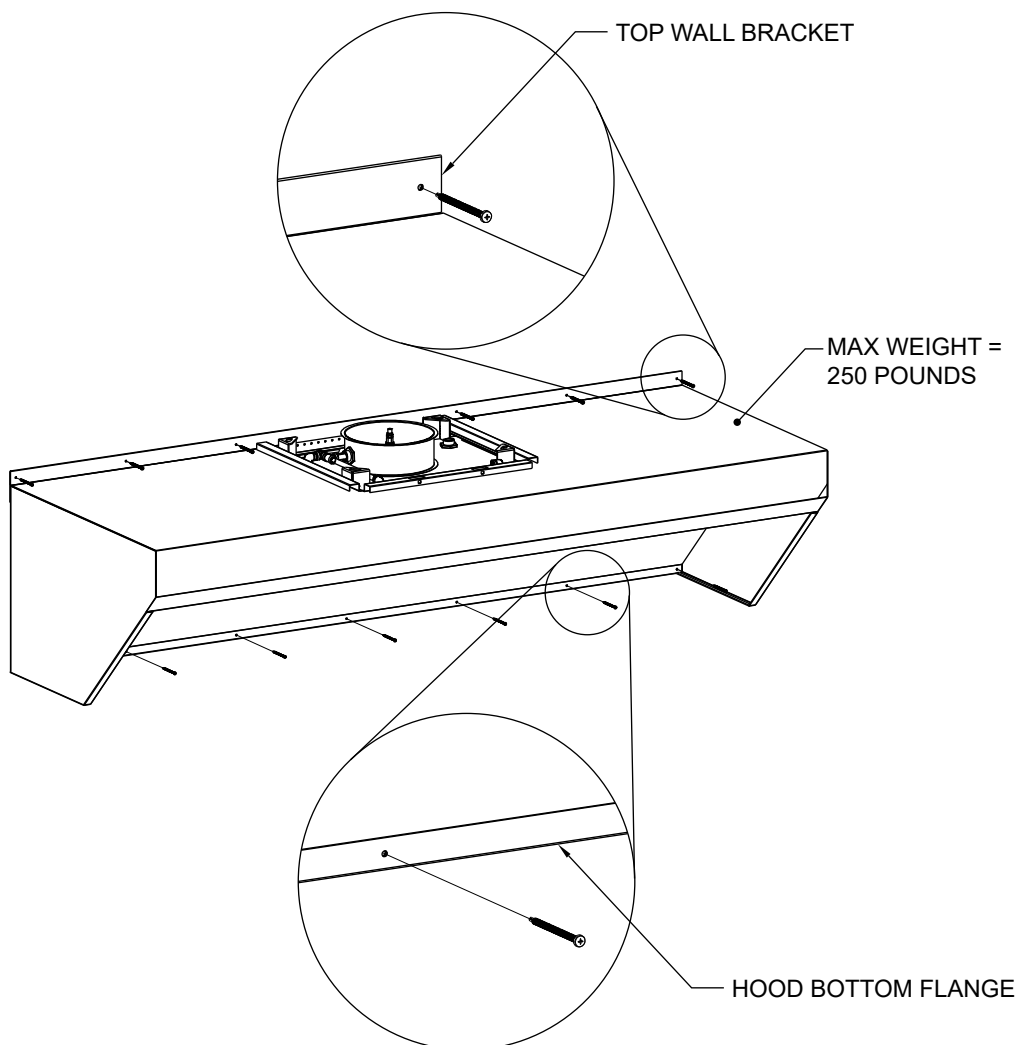

Guidelines for Ductwork Installation

Ductwork is furnished by supplier only if specified by the customer. The following information is provided as a guideline only. Ductwork should be installed in accordance with the local codes and restrictions. It is the responsibility of the installer to check local codes before installing ductwork.

1. All ductwork must be installed in the most direct manner possible.
 2. Exhaust duct must be made of 16 gauge carbon steel, 18 gauge stainless-steel or must be listed for use with commercial kitchen hoods and follow the manufacturer's listing.
 3. Per NFPA 96, all exhaust duct seams and joints must have a continuous liquid tight external weld; exception would be Listed Factory Built Grease Duct.
 4. Exhaust risers on the hood have been sized to achieve a velocity of 500-2200 FPM, per NFPA 96, based upon the CFM required for the hood. Maintain the area of each riser when connecting duct offsets or transitions.
 5. Branches should enter at gradual expansions and at a preferred angle of 30 degrees or 45 degrees if necessary.
 6. When a "pantleg duct" is required to bring two ducts into one exhaust fan, observe the following in order to obtain desired performance:
 - Use ONLY radius back and radius throat elbows. 2 to 2.5-inch diameter center line radius is recommended.
 - Maintain the distance between the center lines of exhaust ducts at a maximum of 12-feet apart.
 - The main duct going to the exhaust fan must be the sum of the area of the separate legs.
 7. Supply air risers are sized around a maximum of 600 FPM. Maintain this area when installing ducts.
 8. Do not use "flexible" type duct for supply duct. Only rigid type duct installed in accordance with SMACNA Low Pressure requirements will be acceptable.
 9. Access Doors should be provided at the sides or at the top of the duct, as well as changes of direction. Please refer to your Authority Having Jurisdiction (AHJ) if there are questions on requirements for horizontal and vertical duct runs.
- IMPORTANT:** When a fusible link is installed in the make-up air damper at the hood collar, an access door must be cut into the supply duct by the installer.
10. Duct sensor may ship loose on hoods with field cut risers. When double wall duct or ductwork with a diameter smaller than 10-inches is used, loose duct sensors should be installed in the top of the plenum near the riser in the path of the exhaust airflow.

Installation of Hood Accessories

Bolt-Together Standoff Installation

Note: Report any damage to the delivering freight carrier and file a claim if appropriate.

Refer to **Figure 12** for standoff details.

1. Unpack the standoff panels from the shipping container, be very careful not to dent or scratch the panels.
2. Mount the end caps for the back standoff to the hood. Clamp the end caps and the hood together before inserting screws so they do not shift. Insert screws through the end cap flanges into the flanges of the hood.
3. Place the back standoff filler piece flush with the rear bottom edge of the hood and secure with self-tapping sheet metal screws. Do not penetrate into the capture area. Once complete, no screws should be visible from the outside of the hood.
4. Continue with hood installation instructions, **See “Installation of a Single Hood (Wall or Island)” on page 7.**
5. After the hood installation is complete, secure the bolt-together standoff to the wall or other hoods as applicable in a manner acceptable by the Authority Having Jurisdiction (AHJ).

Figure 12 - Bolt-Together Standoff

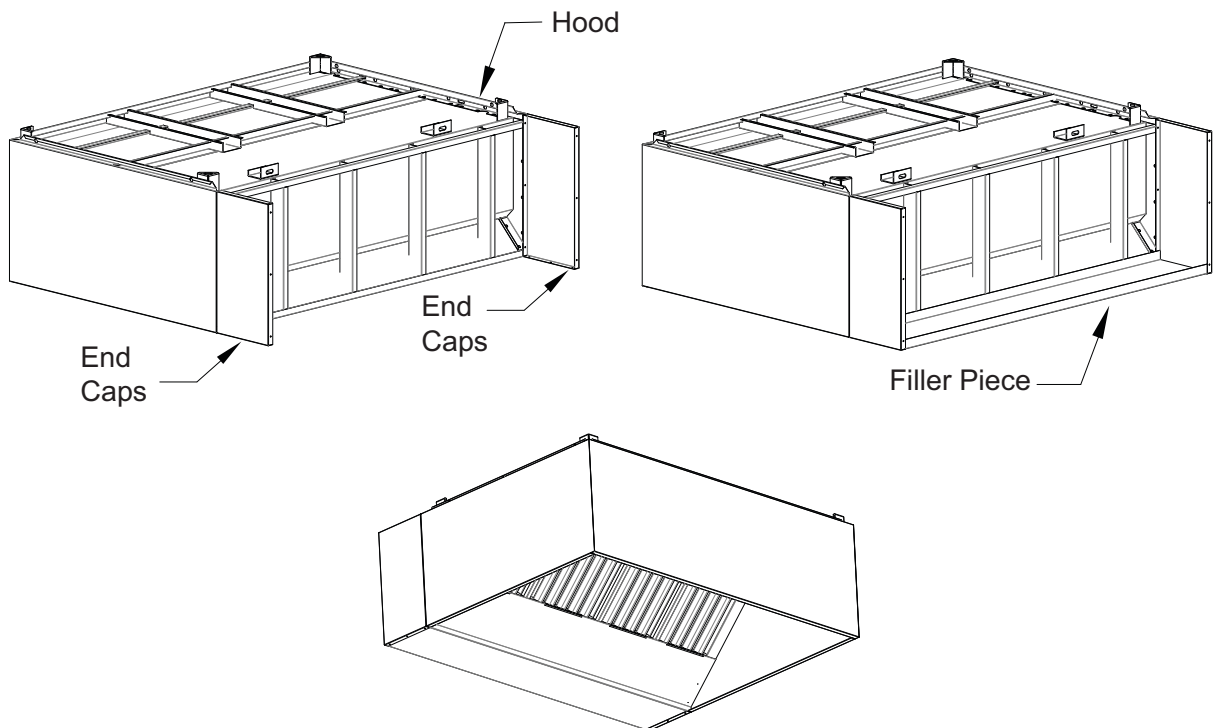

Single PSP/AC-PSP Installation

Note: Report any damage to the delivering freight carrier and file a claim if appropriate.

Refer to **Figure 13** for single PSP/AC-PSP installation details.

1. Locate the assembly and unpack it from the crate, be very careful not to dent or scratch the outer surface. If the supply risers are to be field cut, cut the risers in as desired.
2. Locate the ceiling joists which will support the assembly. If using Unistrut, then securely attach to the ceiling joist.
3. Use 1/2-inch threaded rod to hang the PSP/AC-PSP. Install the threaded rod and angle that will be used to hang the assembly from the ceiling joists. Drill 9/16-inch holes as needed in the angle for the threaded rod. Be sure to line up with the welded-on angle mounting brackets on the PSP/AC-PSP.
4. Peel the protective plastic coating on the hood down below where the bottom edge of the PSP/AC-PSP will rest against the hood.
5. Move the PSP/AC-PSP into position as indicated by the project submittal drawings. If flush mounted, lineup the top edge of the PSP/AC-PSP with the top edge of the hood. Remove the protective plastic coating from the back of the PSP/AC-PSP.

Note: PSPs/AC-PSPs that are not flush mounted with the top of the hood will not use PSP/AC-PSP to Hood Attachment Bracket.

6. Install the threaded rod into the PSP/AC-PSP hanging angles and use heavy-duty nuts to secure the connection. Adjust tension on hanging rods to position PSP/AC-PSP so it fits flush with the hood.

Note: Do not apply too much tension; otherwise, a gap between the PSP/AC-PSP and Hood will be created at the bottom.

7. Where applicable, use sheet metal screws provided from the factory to secure the PSP/AC-PSP attaching bracket to hood. **Use at least 5 sheet metal screws for full size attachment brackets. Use at least 3 sheet metal screws for 1/2 sized attachment brackets.**

Note: Depending on PSP/AC-PSP length and damper placement, there may be 3 or 4 attachment brackets. Hoods and PSPs/AC-PSPs that are 12 feet or greater in length require additional hanging brackets located near the center of the PSP/AC-PSP.

8. Caulk the seams between the hood(s) and the PSP/AC-PSP assembly, as well as between adjacent PSP/AC-PSP assemblies (if applicable) after the hood(s) and hood accessories have been installed.

Figure 13 - Single PSP/AC-PSP

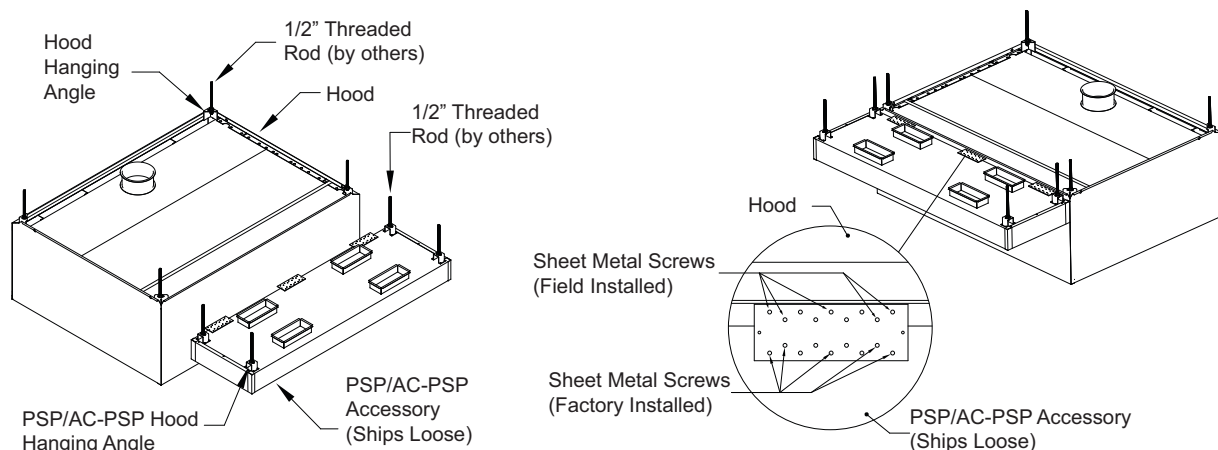

CAUTION: ALL HOOD AND PSP/AC-PSP HANGING ANGLE BRACKETS MUST BE USED DURING INSTALLATION. VERIFY ALL CONNECTIONS ARE SECURED TO CEILING JOISTS OR UNISTRUT. IMPROPER INSTALLATION MAY LEAD TO INJURY AND/OR DEATH.

Multiple PSP/AC-PSP Installation

Note: Report any damage to the delivering freight carrier and file a claim if appropriate.

Refer to **Figure 14** for multiple PSP/AC-PSP installation details.

1. Locate the assembly and unpack it from the crate, be very careful not to dent or scratch the outer surface. If the supply risers are to be field cut, cut the risers in as desired.
2. Upon completion of the hood install, install the back PSP/AC-PSP first. Then if applicable, install the side PSP/AC-PSP.
3. If the supply risers are to be field cut, cut the risers in as desired.
4. Locate the ceiling joists which will support the assembly. If using Unistrut, securely attach to the ceiling joist.
5. Use 1/2-inch threaded rod to hang the PSP/AC-PSP. Install the threaded rod and angle that will be used to hang the assembly from the ceiling joists. Drill 9/16-inch holes in the angle if not using Unistrut. Make sure to line up with the angle mounting brackets on the PSP/AC-PSP.
6. Peel the protective plastic coating on the hood down below where the bottom edge of the PSP/AC-PSP will rest against the hood.
7. Move the PSP/AC-PSP into position as indicated by the project submittal drawings. If flush mounted, lineup the top edge of the PSP/AC-PSP with the top edge of the hood. Remove the protective coating from the back of the PSP/AC-PSP.

Note: PSPs/AC-PSPs that are not flush mounted with the top of the hood will not use PSP/AC-PSP to Hood Attachment Bracket.

8. Install the threaded rod into the PSP/AC-PSP hanging angles and use heavy duty nuts to secure the connection. Adjust tension on hanging rods to position PSP/AC-PSP so it fits flush with the hood.

Note: Do not apply too much tension, otherwise, a gap between the PSP/AC-PSP and Hood will be created at the bottom.

9. Install additional PSPs/AC-PSPs, if applicable, in the same manner.
10. Where applicable, use sheet metal screws provided from the factory to secure the PSP/AC-PSP attaching bracket to other assemblies/hood, **See “PSP/AC-PSP Attachment Brackets” on page 20. Use at least 5 sheet metal screws for full size attachment brackets. Use at least 3 sheet metal screws for 1/2 sized attachment brackets.**

Note: Depending on PSP/AC-PSP length and damper placement, there may be 3 or 4 attachment brackets. Hoods and PSPs/AC-PSPs that are 12 feet or greater in length require additional hanging brackets located near the center of the PSP/AC-PSP.

11. Caulk the seams between the hood(s) and each PSP/AC-PSP, as well as between adjacent PSPs/AC-PSPs (if applicable), after the hood(s) and hood accessories have been installed.

CAUTION: ALL HOOD AND PSP/AC-PSP HANGING ANGLE BRACKETS MUST BE USED DURING INSTALLATION. VERIFY ALL CONNECTION ARE SECURED TO CEILING JOISTS OR UNISTRUT. IMPROPER INSTALLATION MAY LEAD TO INJURY AND/OR DEATH.

Figure 14 - Multiple PSP/AC-PSP

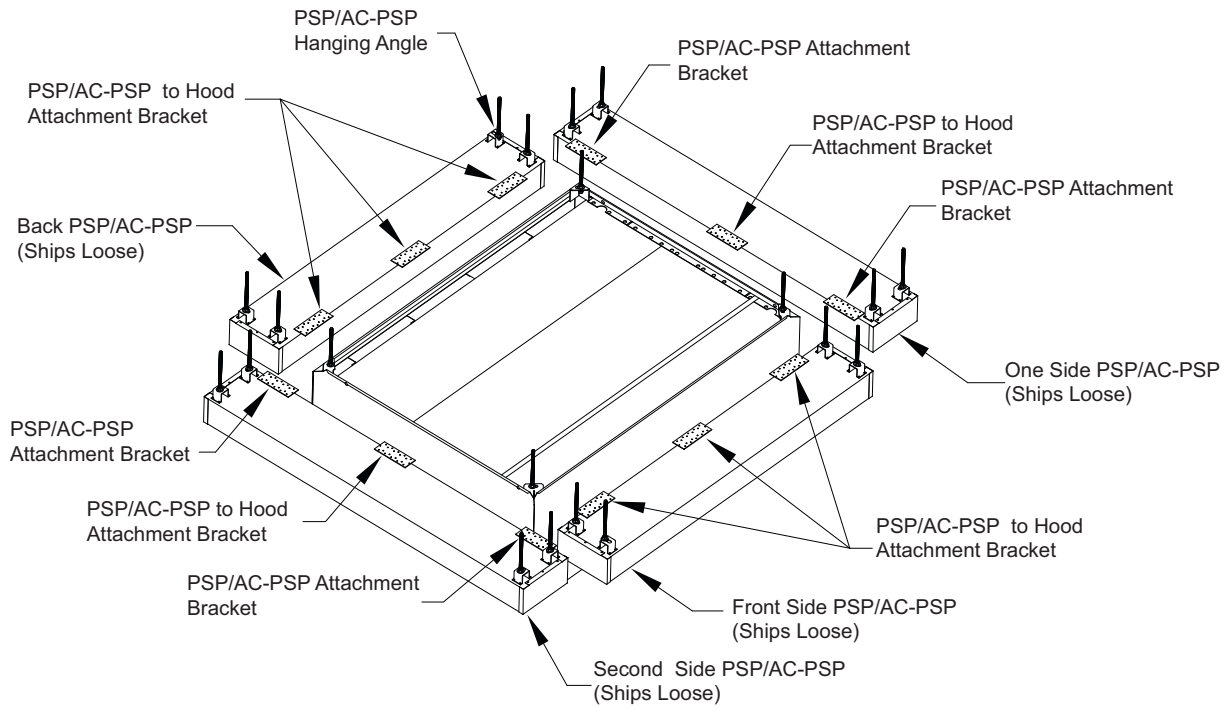

CAUTION: ALL HOOD AND PSP/AC-PSP HANGING ANGLE BRACKETS MUST BE USED DURING INSTALLATION. VERIFY ALL CONNECTIONS ARE SECURED TO CEILING JOISTS OR UNISTRUT. IMPROPER INSTALLATION MAY LEAD TO INJURY AND/OR DEATH.

PSP/AC-PSP Attachment Brackets

Refer to **Figure 15** and **Figure 16** for bracket attachment installation details.

- Once the PSPs/AC-PSPs are aligned in the field, use provided sheet metal screws to attach the other side PSP/AC-PSP attachment bracket to the hood and/or front/back PSP/AC-PSP.
- When attaching PSP/AC-PSP to hood or other PSPs/AC-PSPs; use at least 5 sheet metal screws for full size attachment brackets. Use at least 3 sheet metal screws for 1/2 sized attachment brackets.
- PSPs/AC-PSPs that are not flush mounted with the hood will not use PSP/AC-PSP to Hood Attachment Bracket.

Figure 15 - Attachment of Side PSP/AC-PSP Bracket

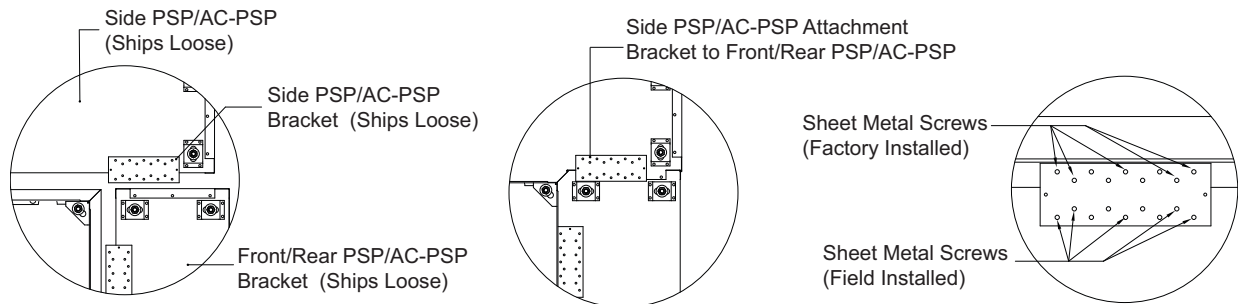
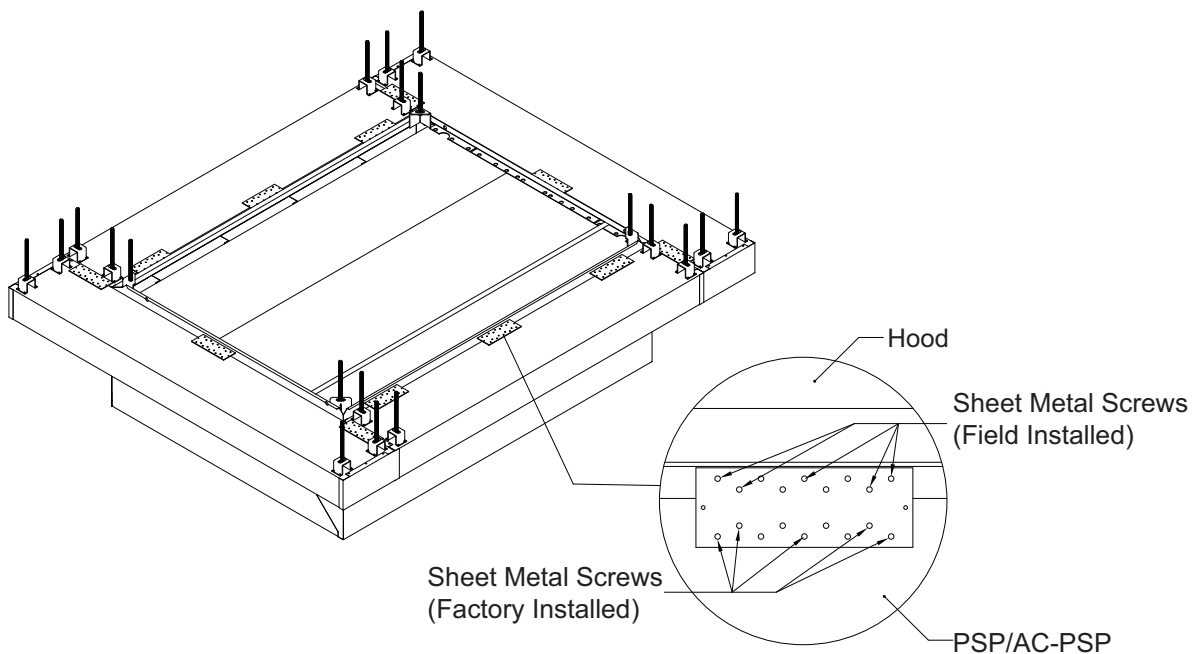

Figure 16 - Attachment of PSP/AC-PSP to Hood



CAUTION: ALL HOOD AND PSP/AC-PSP HANGING ANGLE BRACKETS MUST BE USED DURING INSTALLATION. VERIFY ALL CONNECTIONS ARE SECURED TO CEILING JOISTS OR UNISTRUT. IMPROPER INSTALLATION MAY LEAD TO INJURY AND/OR DEATH.

Wrapper (Enclosure Panel) Installation

Note: Report any damage to the delivering freight carrier and file a claim if appropriate.

1. Unpack the wrapper panels from the shipping container, be very careful not to dent or scratch the panels.
2. Locate one of the side wrapper panels and position it on the hood so that the 1/2-inch flange on the bottom of the panel slips underneath the side channel on top of the hood. Refer to **Figure 17**.

Note: A notch will have to be cut on the wrapper flange using shears (tin snips) where interference occurs, where applicable. Refer to Figure 18.

3. Press fit panel into place until wrapper face is flush with hood face. Screw or pop-rivet wrapper to the side channel and wall. Refer to **Figure 19**.
4. Locate front wrapper panel. Position its lower 1/2-inch flange under front channel on hood and slide panel into position, so that the end of front panel is behind the 90 degree bend of the side panel. Refer to **Figure 20**. Once in place, press fit the lower flange of the front panel into the front channel in order to have wrapper face flush with the front of the hood. Screw or pop-rivet bottom of front panel to the front channel.
5. Drill appropriate holes, and rivet front to side wrapper panel. Refer to **Figure 20**.
6. If multiple panels are used, a stainless trim piece will be provided to attach multiple panels together (i.e. hood is side to side, hood is back to back to another, or the wrapper length exceeds 16 feet). Attach the panels by slipping them behind the stainless trim and fastening with screws or rivets, refer to **Figure 23**.

Note: Trim will have to be cut to fit. In most instances, trim should extend from bottom of hood to top of wrapper panel.

7. Locate the other side panel. Repeat steps 2 and 3. Attach side panel to the front wrapper panel as instructed in step 4.

Note: In most instances where hood is located against a side wall, fasten the front wrapper panel to the wall. Refer to Figure 21.

8. Caulk all gaps and seams after the hood(s) and hood accessories have been installed.

Figure 17 - Wrapper Detail

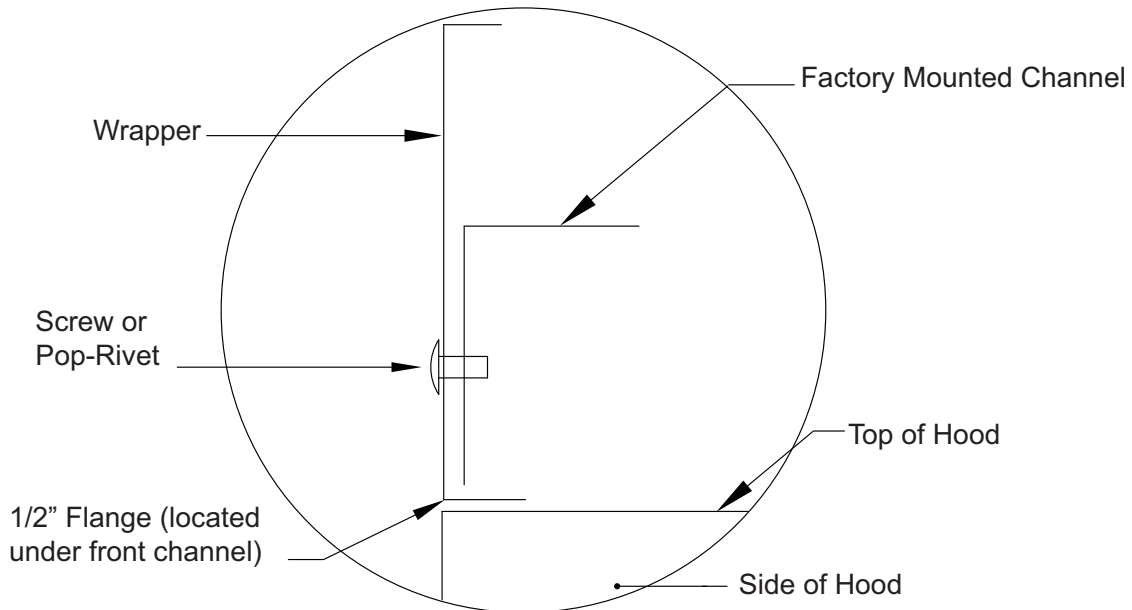
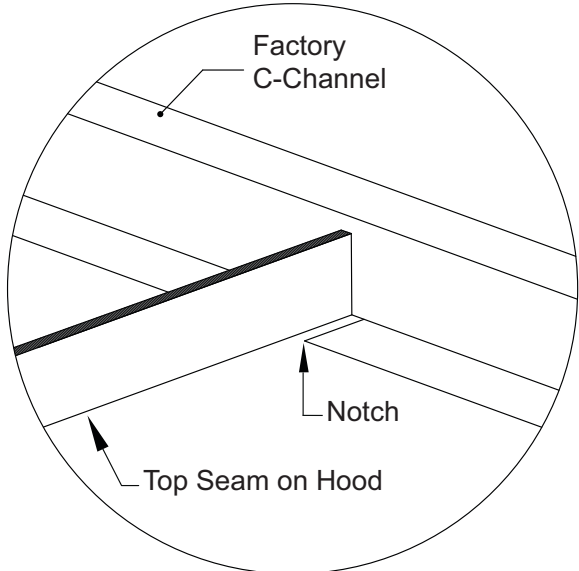

Figure 18 - Top of Hood Seam Detail (Not on all models)



Notch required where seams meets wrapper

Figure 19 - Rear Wall Attachment

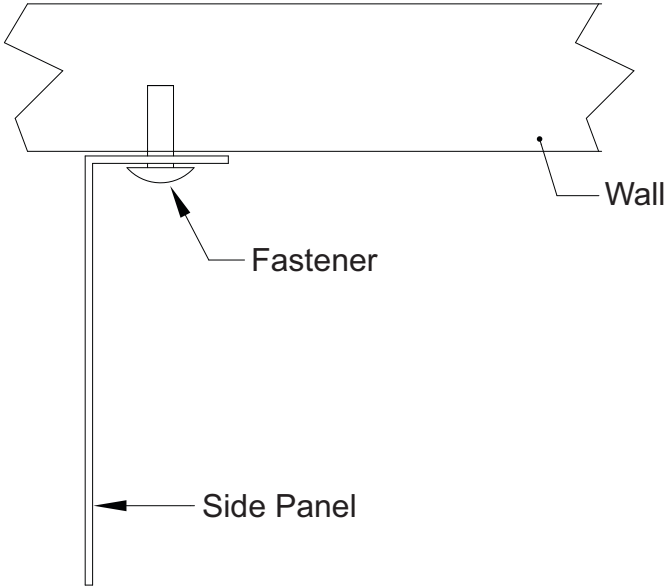
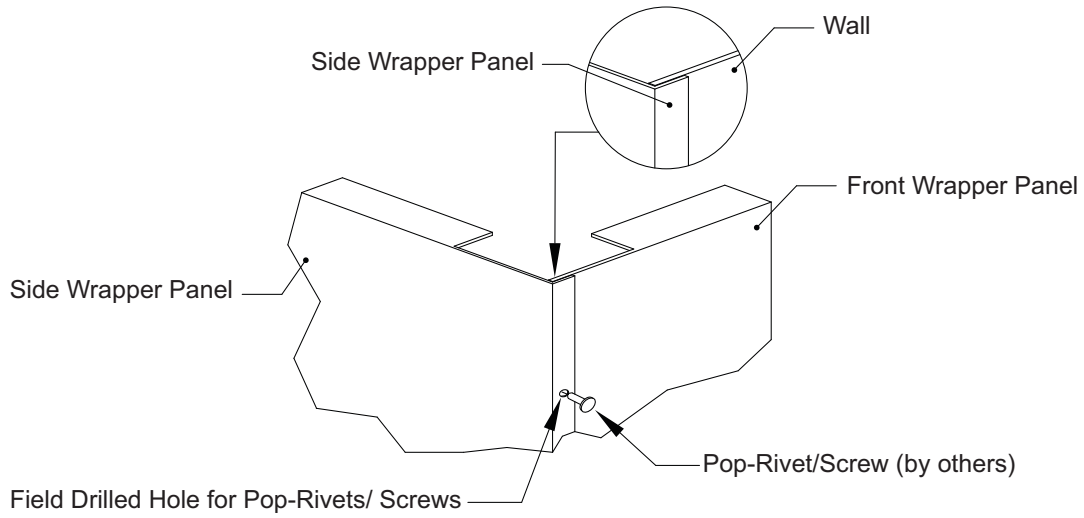

Figure 20 - Front Corner Assembly



Note: Place front wrapper panel under 90 degree bend of the side wrapper panel. Screw or pop-rivet into position.

Figure 21 - Side Wall Attachment

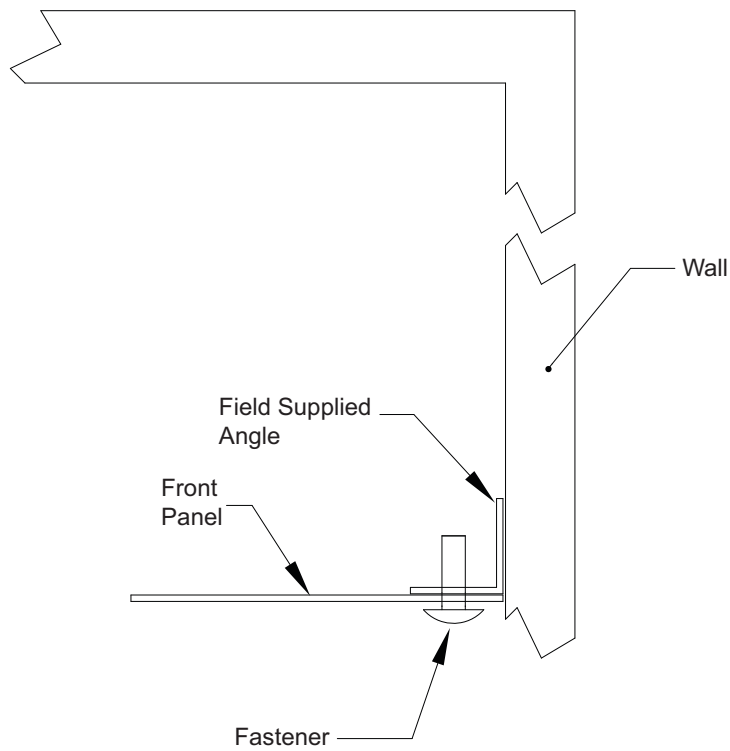
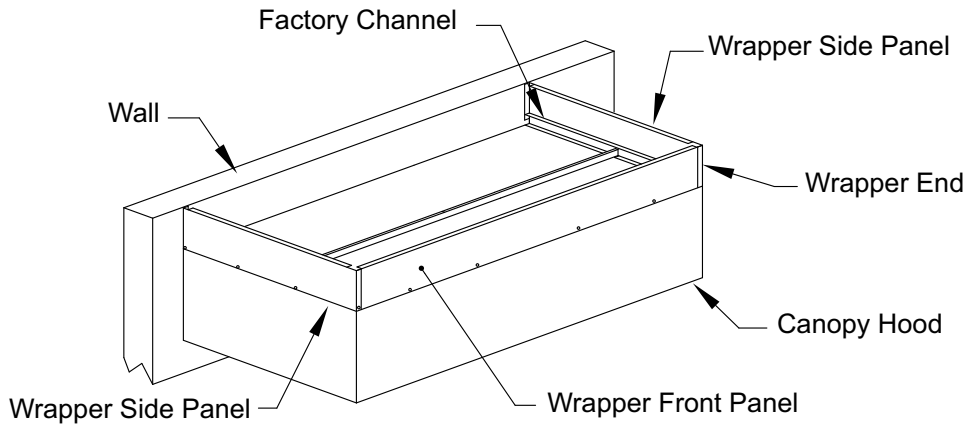

Figure 22 - Completed Wrapper Assembly



Factory Channel - Installer to secure wrapper panel to factory channel.

Wrapper Side Panel - Press fit until panel faces are flush with hood. Pop-riquet or screw panels to hood.

Figure 23 - Completed Wrapper Assembly (End on End)

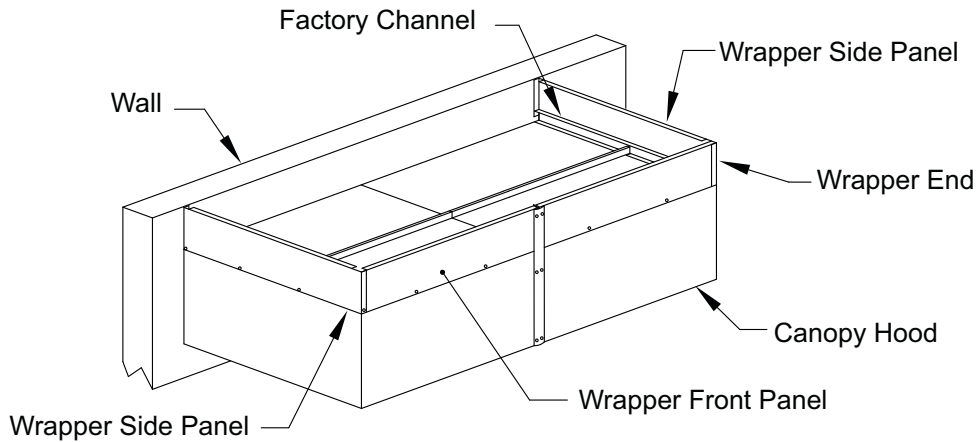

Factory Channel - Installer to secure wrapper panel to factory channel.

Wrapper Side Panel - Press fit until panel faces are flush with hood. Pop-riquet or screw panels to hood.

End Panel Installation

Note: Report any damage to the delivering freight carrier and file a claim if appropriate.

1. Unpack the end panel(s) from the shipping container, being very careful not to dent or scratch the panels. Refer to the project submittal drawings to determine mounting location.
2. Position the end panel with the kinked top flush against the inside of the hood end, and the rear flange flush against the rear wall, facing toward the interior of the hood. Refer to **Figure 24** and **Figure 25**.
3. Attach the top edge of the end panel to the end of the hood using the acorn nuts provided. Hand tighten each acorn nut, use a wrench to tighten an additional 1/4 turn – **do not over-tighten**.
4. Secure the rear flange to the wall using stainless-steel sheet metal screws, make sure to keep the end panel straight vertically.
5. Caulk all seams between the end panel and the hood after the hood(s) and hood accessories have been installed.

Figure 24 - End Panel Installation (Hoods with Hems on Ends)

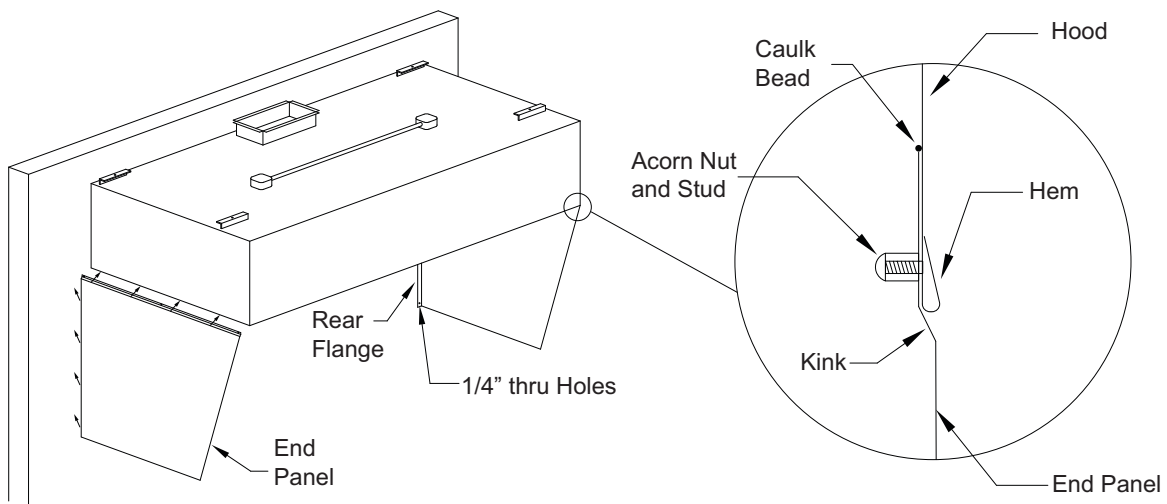
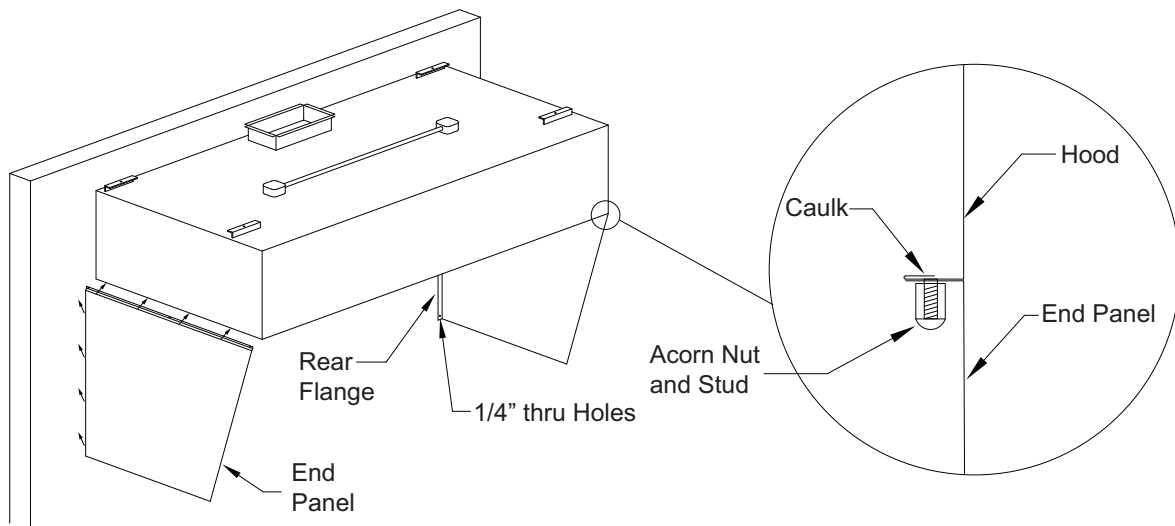

Figure 25 - End Panel Installation (Hoods with Flanges on Ends)



Hood end panels or walls may be field installed or shipped loose from the factory. End panels allow the clearance from the cooking appliance to the end of the hood to be reduced to 0-inch.

Quarter End Panel Installation

1. Follow installation steps from “End Panel Installation” on page 25.
2. Refer to **Figure 26** and **Figure 27** for installation details.

Figure 26 - Quarter End Panel Installation (Hoods with Hems on Ends)

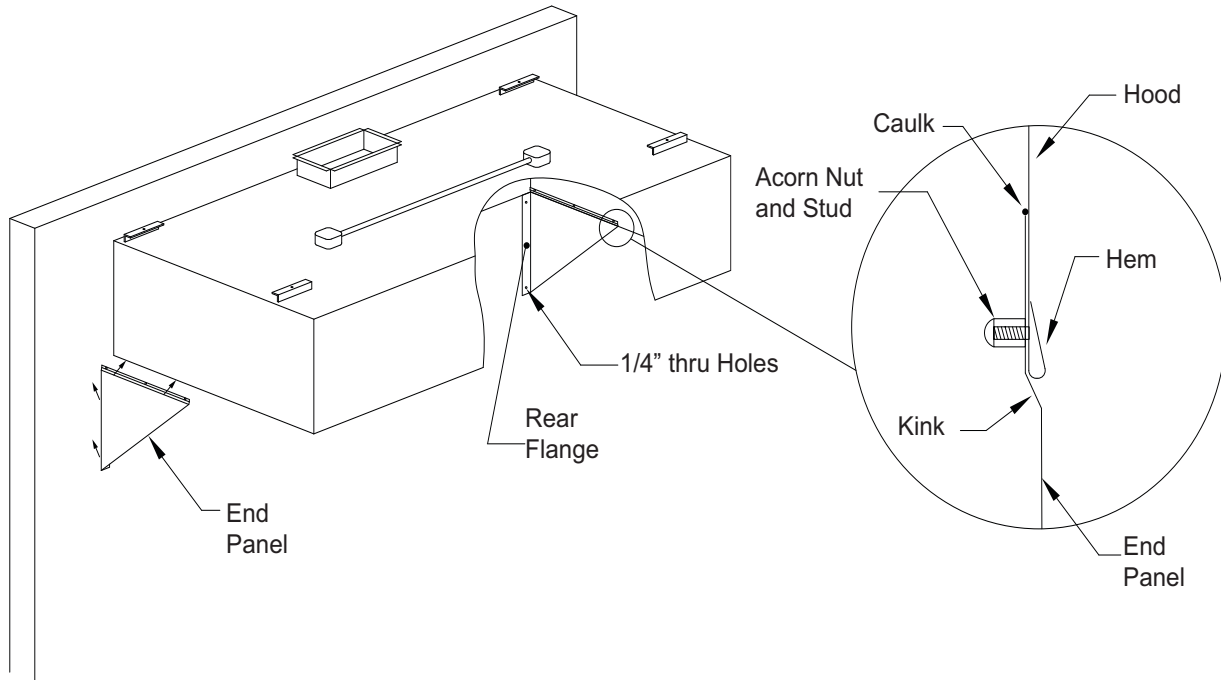
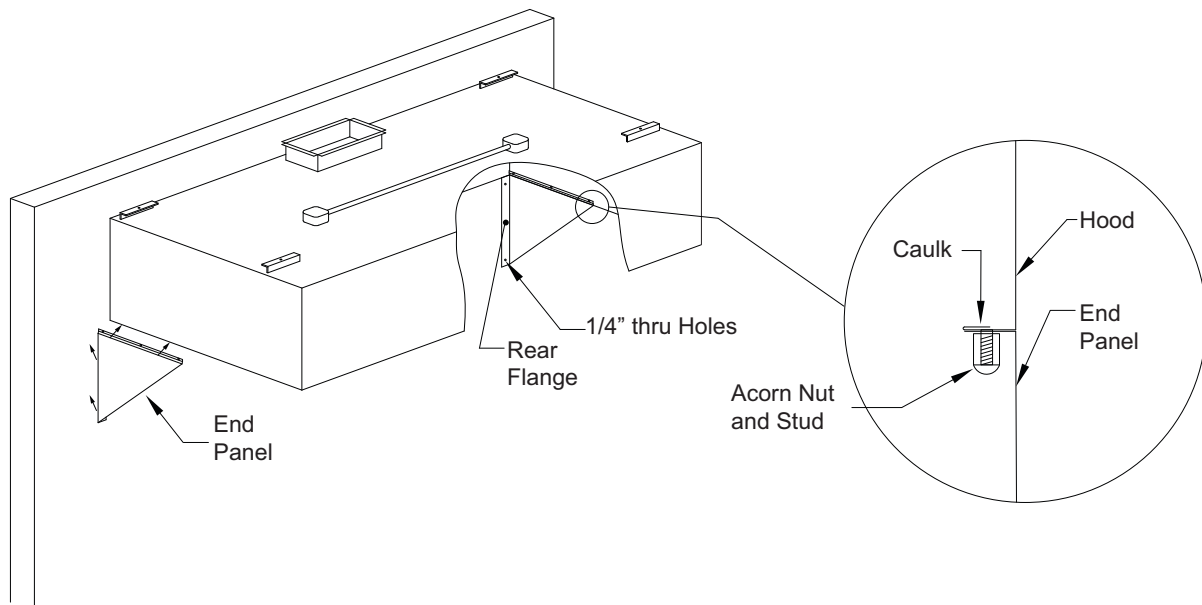

Figure 27 - Quarter End Panel Installation (Hoods with Flanges on Ends)



Hood end panels or walls may be field installed or shipped loose from the factory. End panels allow the clearance from the cooking appliance to the end of the hood to be reduced to 0 inch.

Insulated End Panel Installation

1. Follow installation steps from “End Panel Installation” on page 25.
2. Refer to **Figure 28** and **Figure 29** for installation details.

Figure 28 - Insulated End Panel Installation (Hoods with Hems on Ends)

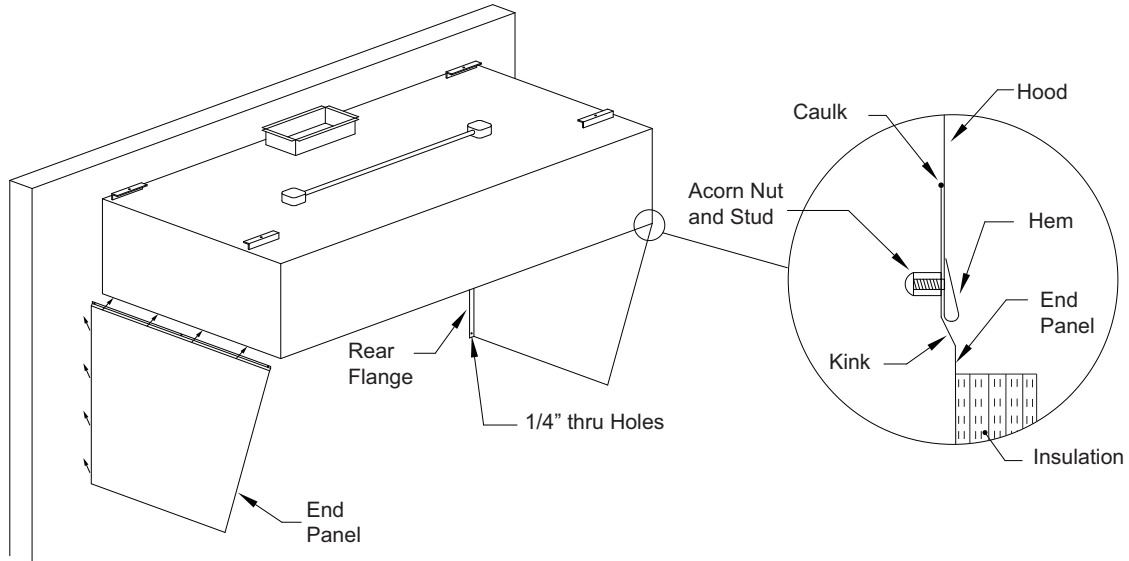
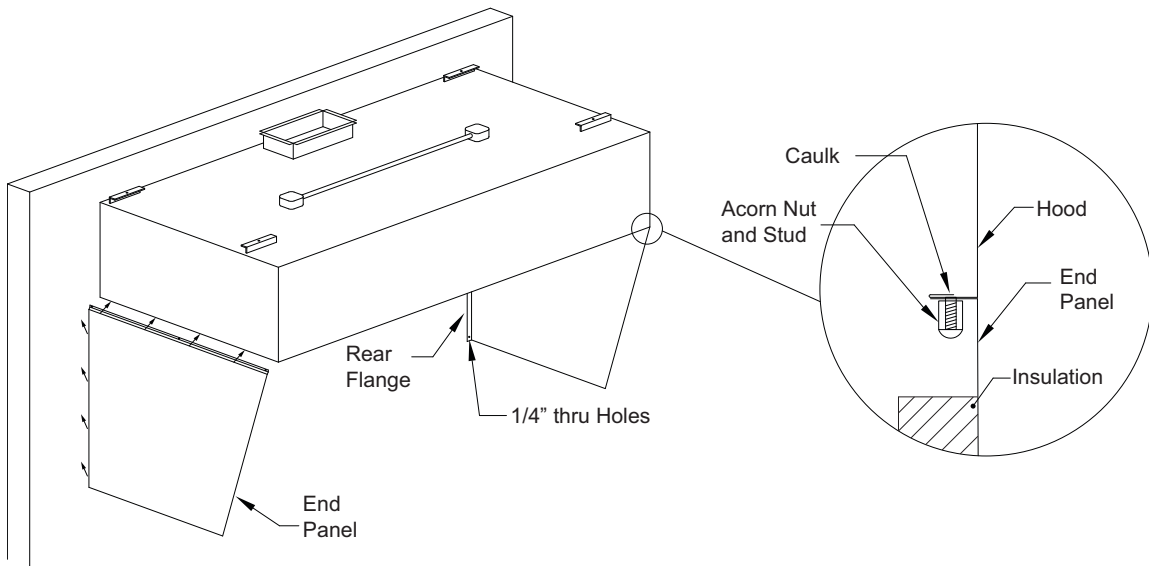

Figure 29 - Insulated End Panel Installation (Flanges on Ends)



Hood end panels or walls may be field installed or shipped loose from the factory. End panels allow the clearance from the cooking appliance to the end of the hood to be reduced to 0 inch.

Vertical End Panel Installation

Note: Report any damage to the delivering freight carrier and file a claim if appropriate.

Refer to **Figure 30** for end panel installation details.

1. Unpack the end panel(s) from the shipping container, being very careful not to dent or scratch the panels. Refer to the project submittal drawings to determine mounting location.
2. Position the end panel with the top located flush against the bottom of the hood end, and the rear flange located flush against the rear wall and facing toward the interior of the hood. Studs on bottom of hood ends should align with slots on top of vertical end panel.
3. Adjust legs to create slight tension between the vertical end panel and bottom of hood. Confirm that the top side of the vertical end panel is flush with the bottom of the hood.

Note: Legs have anchoring points in the feet which are optional to secure to the floor.

4. Secure the rear flange to the wall using stainless-steel sheet metal screws, make sure to keep the end panel straight vertically.
5. Caulk all seams between the vertical end panel and the hood after the hood(s) and hood accessories have been installed.

Figure 30 - Vertical End Hoods with Flanges on Ends

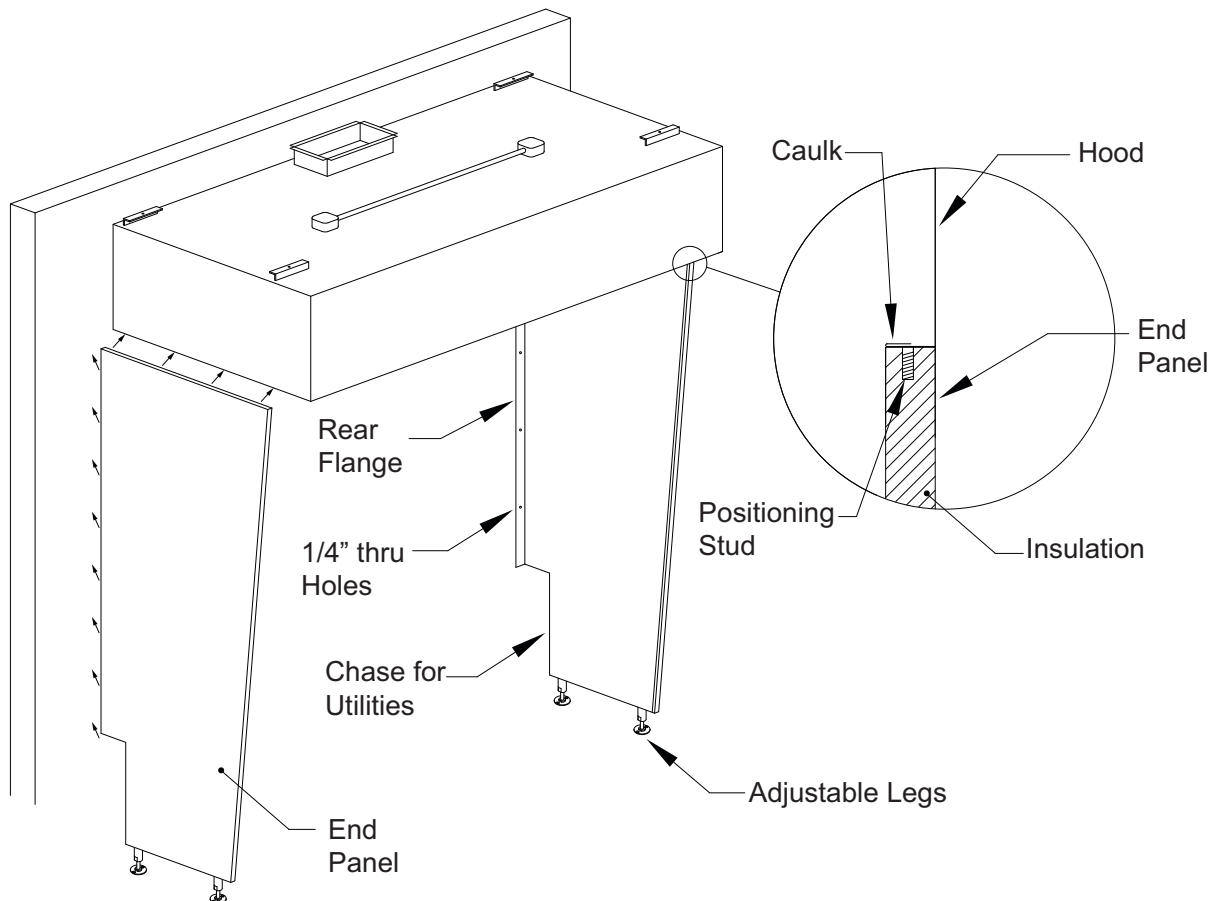

Hood end panels or walls may be field installed or shipped loose from the factory. End panels allow the clearance from the cooking appliance to the end of the hood to be reduced to 0 inches.

Backsplash Installation

Note: Report any damage to the delivering freight carrier and file a claim if appropriate.

Refer to **Figure 31** for stainless-steel backsplash installation details.

1. Unpack the backsplash panels from the shipping container being very careful not to dent or scratch the outer surface.
2. Refer to the project submittal drawings to determine mounting orientation (vertical or horizontal) and mounting location. If backsplash panels intended for the same wall are of different widths, position them in a symmetrical arrangement.
3. Determine if cutouts are required to accommodate electrical outlets, pipes, etc. Make appropriate cutouts being careful not to crease the backsplash panels.
4. Make sure that the walls are clean and free of debris.
5. Apply Titebond® Advanced Polymer Panel Adhesive or equivalent recommended for stainless-steel to backsplash panels and trim pieces. Do not allow the adhesive to dry. Use a trowel to spread adhesive in a smooth, even manner to the edges and corners. **Do not allow clumping or bumps on the backside of the panel.**
6. Install the backsplash panels to the wall. When hanging multiple panels, install one at a time. Install trim pieces to the wall.
7. Once the panels are installed, immediately use a laminate roller to smooth the panel and adhesive out. **Do not press on the panel with hands or other foreign objects at all.**
8. Verify all backsplash panels are installed and have properly set before placing appliances or other objects in front of the panels.

Note: Follow adhesive manufacturer's recommendations on setting and dry time.

Figure 31 - Stainless-Steel Backsplash

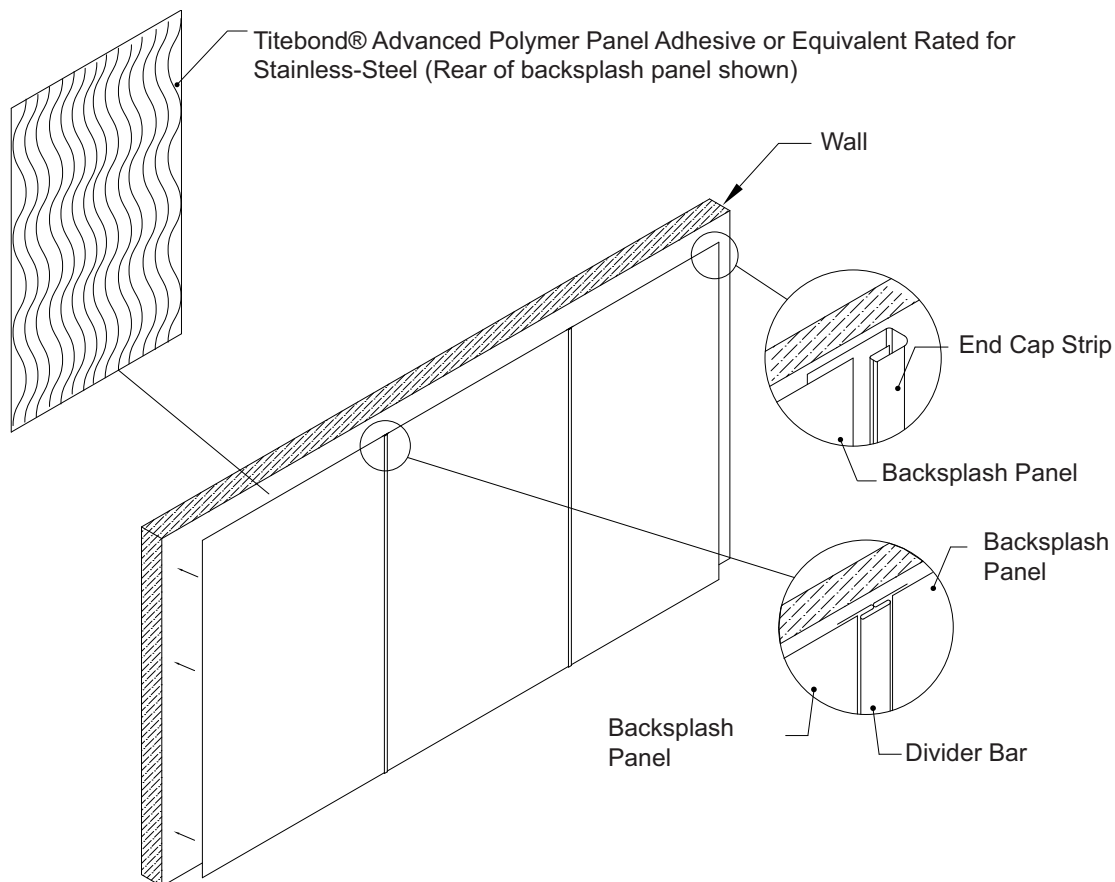

Insulated Backsplash Installation

Note: Report any damage to the delivering freight carrier and file a claim if appropriate.

Refer to **Figure 32** for insulated backsplash installation details.

1. Unpack the backsplash panels from the shipping container being very careful not to dent or scratch the outer surface.
2. Refer to the project submittal drawings to determine mounting orientation (vertical or horizontal) and mounting location. If backsplash panels intended for the same wall are of different widths, position them in a symmetrical arrangement.
3. Determine if cutouts are required to accommodate electrical outlets, pipes, etc. Make appropriate cutouts being careful not to crease the backsplash panels.
4. Slide the top flange behind the lower rear edge of the hood. Secure the bottom flange to the wall using stainless-steel sheet metal screws.
5. If there are multiple insulated backsplash sections, install the others now.
6. Caulk the seams between the wall and the insulated backsplash panel after the hood(s) and hood accessories have been installed.

Figure 32 - Insulated Backsplash

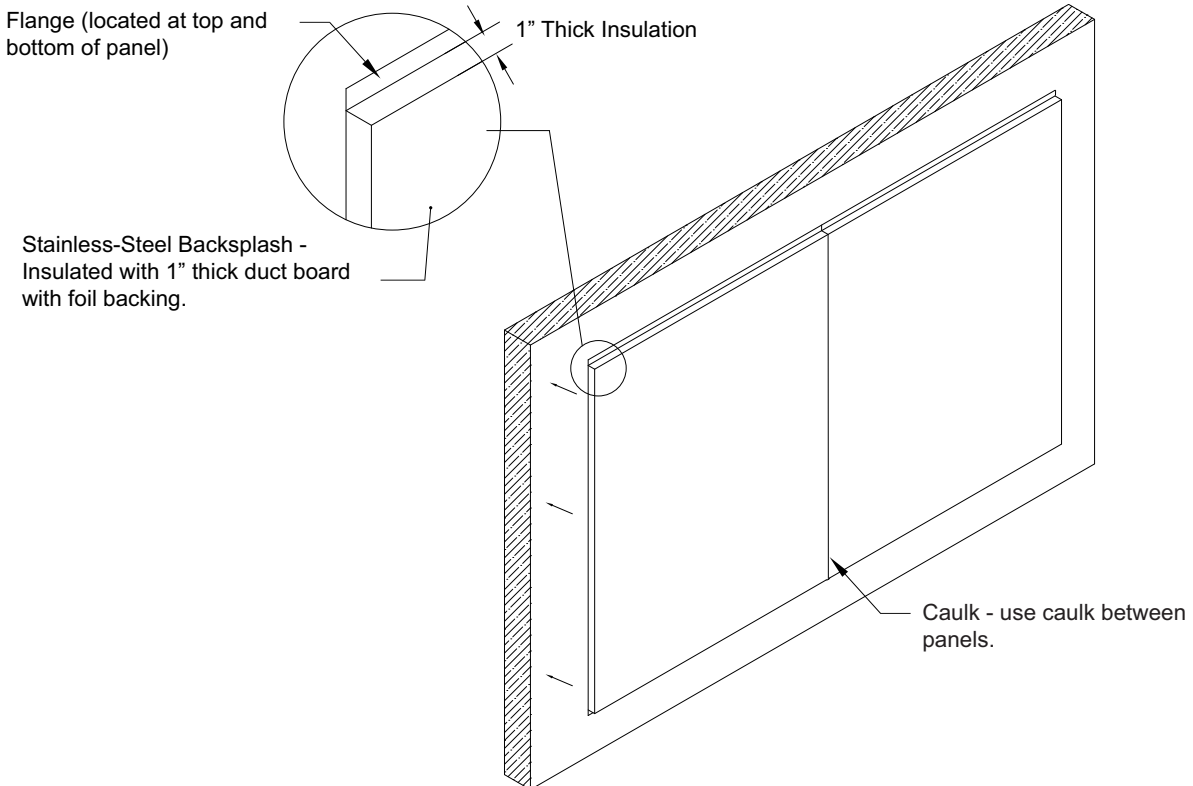

Pizza Oven Top Mount Flange Installation

Note: Report any damage to the delivering freight carrier and file a claim if appropriate.

Refer to **Figure 33** for pizza oven top mount details.

1. Thoroughly inspect hood for damage including Pizza Oven Top Mount Flanges.
2. Carefully unpack hood, remove shipping screws from rear flange before moving hood.
3. Use supplied 3M 2000+ fire barrier sealant to apply a double bead to the underside of the flanges.
4. Centrally position the hood on top of the oven over the opening. The front edge of the side flanges should be flush with the front face of the oven.
5. Use supplied 5/16"-18 self-drilling screws to fasten hood to oven. Every mounting hole needs to be used.

Figure 33 - Pizza Oven Top Mount

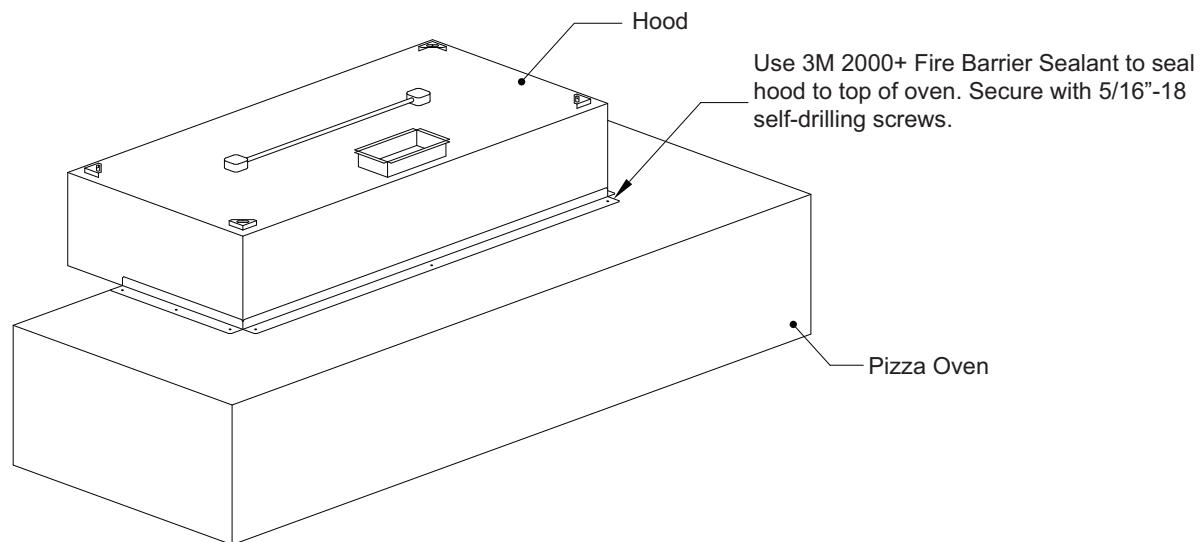

Plate Shelf Option Installation

Note: Report any damage to the delivering freight carrier and file a claim if appropriate.

Refer to **Figure 34** for plate shelf installation details.

The plate shelf option may come with the wrapper installed from the factory or for field installation. For field installation, refer to **“Wrapper (Enclosure Panel) Installation”** on page 21.

Figure 34 - Plate Shelf Option Installation

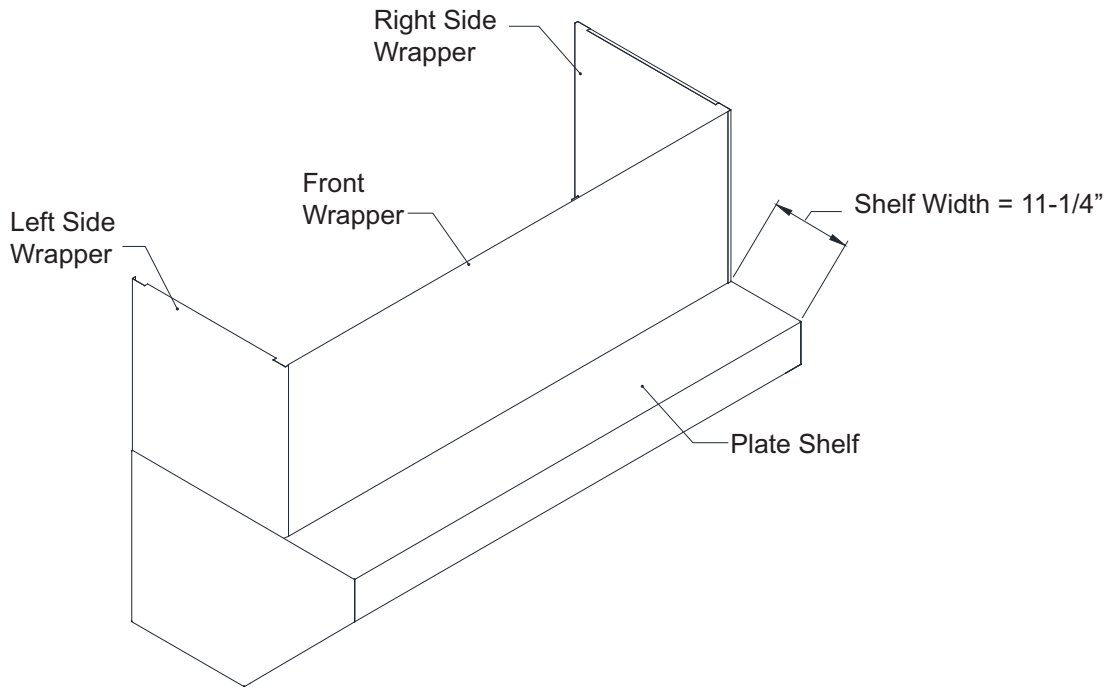

Pass-Through Option Installation

Refer to **Figure 35** for pass-through installation details.

The pass-through option may come with the wrapper installed from the factory or for field installation. For field installation, refer to **“Wrapper (Enclosure Panel) Installation”** on page 21.

NOTE: The front and optional back panel of this particular hood are **NOT** riveted in place. Instead, they use 10-32 cage nuts and pan head screws to secure them in place. This is so the front/back panels can be removed, and the internal duct and fire system components can be easily accessed for final installation and service.

Figure 35 - Pass-Through Hood Option

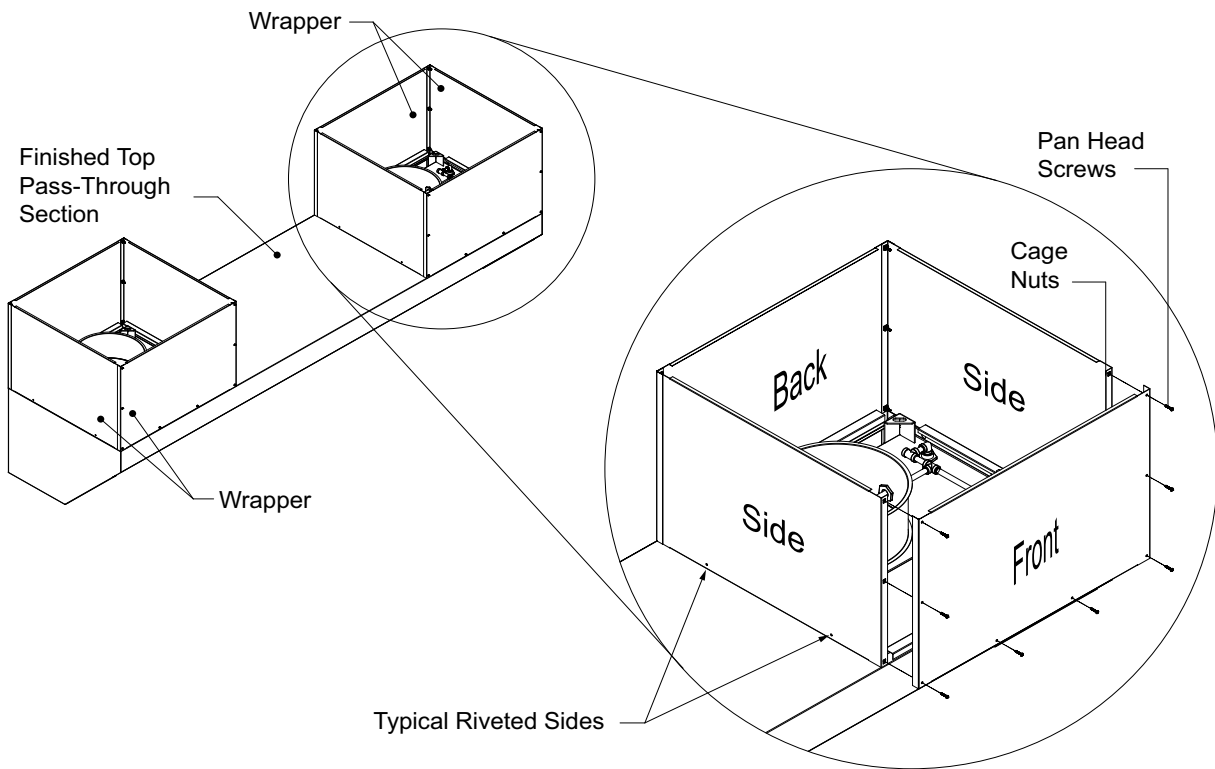

Continuous Capture Option

The hood is shipped with a U-trim to cap the raw edges of the continuous capture cutout(s).

Refer to **Figure 36** for continuous capture details.

1. Remove U-trim from packaging.
2. Measure and cut U-trim to length for all four edges of the continuous capture cutout(s).
3. Dry fit the cut pieces of U-trim to verify a proper finished fit.
4. Remove fitted U-trim pieces and apply silver silicone caulking to raw edges of the continuous capture cutout(s).
5. Reinstall fitted U-trim pieces to seal the raw edges of the continuous capture cutout(s).
6. Wipe off any excess caulking with a cotton cloth and rubbing alcohol.

Figure 36 - Continuous Capture

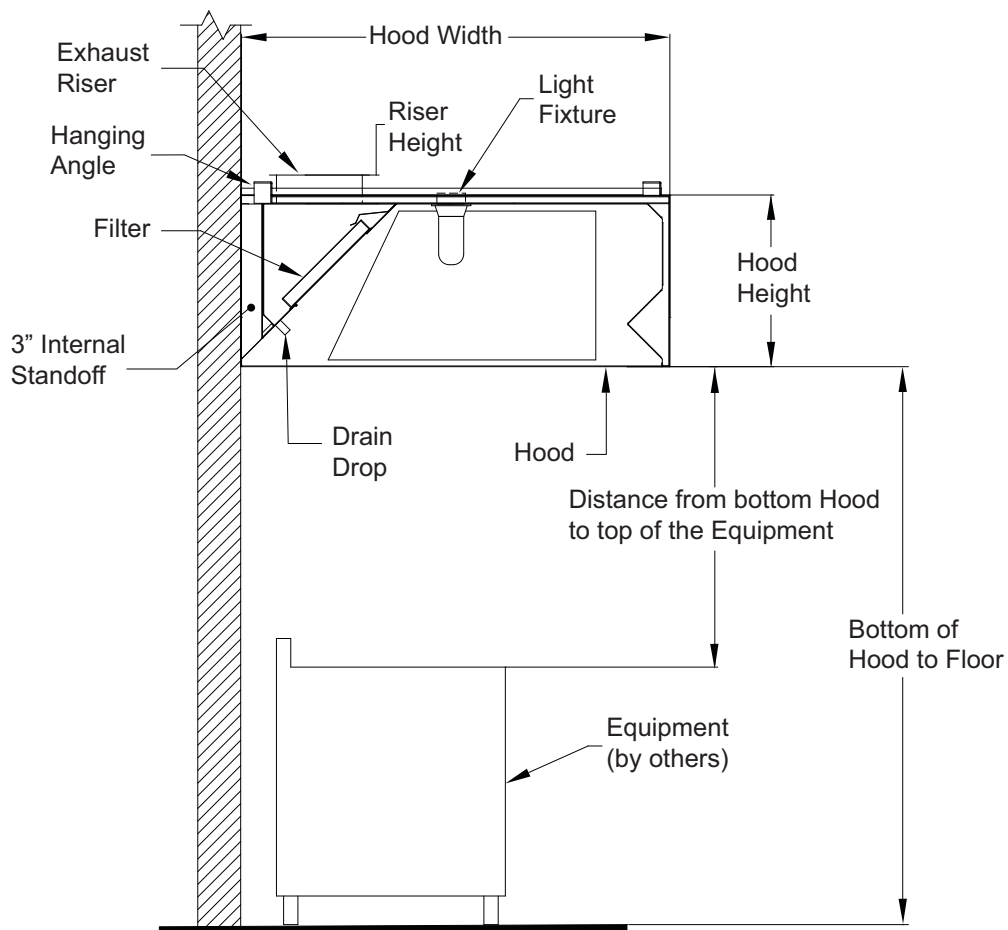

Note: It is the responsibility of the Architect/Owner to ensure that the hood clearance from limited-combustibles and combustible materials is in compliance with local codes requirements.

Engineer is responsible for drain line design beyond the hood. Drain line must be installed per local codes. The drain line must be sloped (minimum 1/4 inch per foot). Avoid unnecessary 90° turns; if combined with other drain lines then the pipe size should be increased accordingly. P-traps should not be used in the grease drain line, and heat tape must be used where the drain line will be routed in environments that would solidify grease. All necessary fittings from the ventilator to the building waste line, i.e. floor, sinks, air gaps, or other devices required by governing codes are furnished. Refer to drain kit details.

OPERATION

Commercial kitchen ventilation hoods are intended to be used in conjunction with ductwork and fans which have been properly sized and installed in accordance with manufacturer's specifications and local code requirements.

Before turning on cooking equipment, make sure that the make-up air and exhaust fans are on. Leave fans on for at least 30 minutes after cooking equipment is shut off.

Clean hood as needed to comply with local code requirements and as directed in **"MAINTENANCE"** on page 40.

Performance Evaluation

A performance evaluation of the system can be performed only after all of the following items have been verified:

- All fans are operational. Visually inspect fan rotation with directional arrow.
- All filters are in place.
- Equipment under the hood is in place and operational.
- HVAC units are in place and operational with blowers operating correctly.

Guidelines before Beginning

The testing and balancing of a system is necessary to ensure proper and efficient operation of the system as it was designed. In any building where effluent and hot air is removed, the mass of air must be replaced to maintain a constant pressure in the space. Any change in the pressure differential between inside and outside air will in some way affect the operation of a system; most commonly that affect is a negative one.

A test and balance, as well as the simple performance test in International Mechanical Code Section 507.16.1 should be included in all jobs; code inspectors are increasingly enforcing these requirements. Requirements in the 2006 IMC, which is currently effective in most parts of the United States, are as follows:

"507.16 Performance test. A performance test shall be conducted upon completion and before final approval of the installation of a ventilation system serving commercial cooking appliances. The test shall verify the rate of exhaust airflow required by Section 507.13, makeup airflow required by Section 508, and proper operation as specified in this chapter. The permit holder shall furnish the necessary test equipment and devices required to perform the tests.

507.16.1 Capture and containment test. The permit holder shall verify capture and containment performance of the exhaust system. This field test shall be conducted with all appliances under the hood at operating temperatures, with all sources of outdoor air providing makeup air for the hood operating and with all sources of recirculated air providing conditioning for the space in which the hood is operating. Capture and containment shall be verified visually by observing smoke or steam produced by actual or simulated cooking, such as with smoke candles, smoke puffers, etc."

The simplest means of doing the performance test is using a T-T smoke puffer. Activate the puffer and use it to trace effluent around the entire perimeter of the hood, emitting smoke every few inches under the lower edges of the hood.

External Factors which may affect Hood Performance

1. HVAC units are generally specified to supply 25% outside air (OA) to the room ventilation. If RTUs are not supplying the proper amount of OA to the building, then negative pressure will exist.
2. HVAC return grilles located close to a hood can cause performance problems. The return grille competes with the hood to capture air in the room. For example, a return grille for a 10-ton HVAC unit can draw anywhere from 3000 to 4000 CFM. This is equivalent to the exhaust of a 10-foot to 13-foot canopy hood. As a result, a return air grille located within 6 feet of the hood can have a serious effect on the capture ability of the hood.

Note: High velocity diffusers or HVAC returns should not be placed within 10 feet of the exhaust hood. Perforated diffusers are recommended.

3. HVAC diffusers located near a hood can create flows in the room that detract from the capture ability of the hood. If the HVAC diffuser bounces air off the front of the hood or directs air along the hood and past the end, the air flow created can draw smoke and contaminants out of the hood.

Using a Shortridge Instrument

The Shortridge is a sophisticated instrument that, with its built-in features, is basically a self-contained test and balance kit. It has a "velocity grid" for filter face readings, a "velocity probe" for ductwork readings, a "differential pressure" function to check room pressure and static pressure, as well as a "temperature probe" so it can calculate accurate values based on varying temperature (most equipment assumes standard temperature and pressure), and many other useful features.

Hood Information

To calculate the CFM, the following information must first be acquired:

1. Hood size and length
2. Filter size and length
3. PSP width and length

Measuring Hood Static and Room Pressure

- Static Pressure - Measure hood static pressure at exhaust collar using the Shortridge instrument.

Static Pressure = _____

- Room Pressure - For an exhaust hood to work properly, the kitchen should be at a slight negative pressure to the dining area (caused by its air removal) and the building overall slightly positive. The dining room should be a slight positive to the outdoors and the kitchen +0.02" w.c. or about 300 CFM positive. This will keep dust and bugs outside, and doors will be easy to open. The kitchen should be a slight negative to the dining room to keep the odors in the kitchen. The kitchen should be balanced to slightly negative, 0" to -0.02" w.c., to the dining room. Generally, if there is not enough negative, or if there is positive pressure there will be smoke roll out from the hood that occurs due to the wind currents from people moving around in the area, while if there is too much negative, there becomes a pressure problem on the building (opening doors, drafts, hot water heaters, etc.)

Measure room static pressure using the Shortridge instrument. Adjust the supply fan to set room to 0.02" negative to dining area.

Room Pressure = _____

Calculating Make-up Air CFM

With a Shortridge Instrument and Spreadsheet

1. Use the Velgrid mode of the Shortridge instrument to measure supply air velocity. Make sure to take measurements every twelve (12) inches along the length of the PSP/AC-PSP.
2. Locate the appropriate Excel spreadsheet for the PSP/AC-PSP Supply velocity and record all necessary data. This spreadsheet will calculate the total supply CFM for the hood.
3. The spreadsheet is located on the manufacturer's website.

Without a Shortridge Instrument

1. Compute the open area of the supply plenum of the hood. This area must be calculated at the same plane that velocity readings are taken. Area can be calculated using the following formula:

$$\text{Area (ft}^2\text{)} = \text{Length (ft)} \times \text{Width (ft)}$$

If both the length and width are measured in inches, use the following formula:

$$\text{Area (ft}^2\text{)} = \text{Length (in)} \times \text{Width (in)} / 144$$

2. Record velocity of air through supply openings from left to right on raw data sheet.
3. Compute and record average velocity through supply openings.
4. Compute and record CFM through supply openings.

$$\text{CFM} = \text{Free area} \times \text{Average Velocity}$$

5. Compute total CFM through all supply openings for each hood.

Calculating Exhaust Air CFM

1. Record filter sizes of each hood on raw data sheet.
2. Compute free area of the filters.

$$\text{Examples: } 16'' \times 16'' = 14 \times 14 = 1.36 \text{ ft}^2$$

$$10'' \times 20'' = 8 \times 18 = 1.00 \text{ ft}^2$$

$$12'' \times 16'' = 10 \times 14 = 0.97 \text{ ft}^2$$

3. Record velocity of exhaust gases through filters starting top left to right (5 reading/filter).
4. Find average velocity through each filter.
5. Compute CFM through each filter.

$$\text{CFM} = \text{Free area} \times \text{Average Velocity}$$

6. Total the exhaust CFM for each hood.
7. Multiply total exhaust CFM x 0.78 (this is the K factor necessary when using the EDRA velometer).

Adjustments

1. A hood with multiple risers should be balanced according to the cooking load beneath it. For example, if a hood with multiple risers has a charbroiler in the center and several ovens on the ends, the risers should be evenly balanced. This will achieve the most efficient contaminant capture.
2. Perforated supply plenums discharging air around the hood should be set to the designed discharge velocity.
3. When fan pulleys are adjusted, belts should then be re-checked for correct tension and an amperage reading should be taken on the motor to make certain it is not overloaded.
4. The prime objective of balancing is to ensure that each hood will capture all the contaminants produced by the equipment it covers without causing undesirable conditions in the kitchen (i.e. excessive negative pressure, excessive quantities of hot or cold air in the kitchen, etc.)
5. If problems occur, refer to “**TROUBLESHOOTING**” on page 39.

Conclusion

1. Compare specified data to the data recorded. Adjust exhaust as necessary using adjustable pulley on fan. Adjust supply as necessary using dampers on supply risers and adjustable pulley on supply fan.
2. After setting hoods to specified data, the room parameters should be checked.
3. If room parameters are not acceptable yet, the hood can be modified to improve them without decreasing hood performance. This is an acceptable condition.
4. Use a smoke bomb to verify that the hood captures adequately. This can be your final verification.

Complete Equipment List for Performance Evaluations

- Closed End Wrenches (9/16, 1/2, 7/16, 3/8, 5/16, 1/4)
- Socket Set & Ratchet (9/16, 1/2, 7/16, 3/8, 5/16, 1/4)
- Extension for Ratchet
- Cheater Bar
- Screwdrivers (Phillips & Standard, Short & Long)
- Adjustable Wrenches (Large & Small)
- 5/32" Allen Wrench 9" Long
- Multi-key Hex Set (Standard Assortment)
- Tape Measure, Hammers (Hard & Soft)
- 2-Channel Locks
- Vise-Grip Pliers (Medium Size)
- Shortridge Air Multimeter
- Velometer or similar unit, Edra 5LV or Davis LCA6000 recommended
- Manometer or similar unit, Dwyer Magnehelic Model #2000-00 recommended
- Work Gloves
- 6' Step Ladder
- 20' Extension Ladder
- Tachometer (Mechanical)
- Amprobe (Volt & Amp Meter)

TROUBLESHOOTING

The following chart lists causes and corrective actions for possible problems with exhaust hoods. Review this list prior to consulting manufacturer.

Problem	Potential Cause	Corrective Action
Smoke is not being captured/ Low Exhaust	Filters are clogged	Clean filters, refer to “MAINTENANCE” on page 40.
	Extreme negative pressure in space	Increase MUA Quantity to balance building
	Exhaust Fan operating in incorrect direction	Check motor wiring to wiring diagram located on fan motor.
	Hood overhang on appliance is not correct	Hood should overhang cooking appliances adequately.
	Exhaust airflow too low	Increase exhaust fan RPM/HP.
	Exhaust duct static pressure higher than design	Increase exhaust fan RPM/HP or have ductwork re-worked.
No Exhaust	Exhaust Fan not running	Turn fan disconnect on. Check fan belts Check circuit breaker/voltage. Check wiring connections.
	Exhaust Fan running backwards	Wheel should turn per rotation arrow on fan. 3 Phase Motor direction may be reversed by switching any 2 leads. 1 Phase Motors must be wired per their label.
	Fan is on incorrect hood	Make sure electrical package is controlling the correct fan
No Make-Up Air	Make-Up Air Fan not running	Turn fan disconnect on Check fan belts Check circuit breaker/voltage
	Make-Up Air Damper closed	Ensure blades open on damper
	Make-Up Air Fan running backwards	Wheel should turn per rotation arrow on fan. 3 Phase Motor direction may be reversed by switching any 2 leads. 1 Phase Motors must be wired per their label.
	Make-Up Air Duct Static Pressure higher than design	Eliminate flexible ductwork and remove number of elbows in duct.
	Clogged Make-Up Air Filters	Clean filters, refer to “MAINTENANCE” on page 40
	Fire System activated or not armed	Micro-switch on Fire System is keeping make-up air from operating and fire system must be armed
Exhaust/Make-Up Air motor cycles on and off	Motor Over-amping	Make sure motor amperage is below FLA of motor label Ensure motor wiring is adequately sized
	Exhaust air temperature too high	Increase exhaust airflow or use higher temperature rated motor
Grease does not drain	Grease trough full	Clean grease trough behind hood filters.
Grease dripping from hood	Hood not being cleaned often enough	Clean surface of hood more frequently.
	Exhaust rate too low	Speed up exhaust fan.
Hood is vibrating	Vibrating Exhaust or MUA Fan	Find source of vibration in fans and correct (Often times a rag or other debris will be in exhaust fan wheel).
Light Globes are full of fluid	Duct Leak above hood	Check ductwork or fan to roof connection for leaks and seal where necessary

MAINTENANCE

To guarantee trouble-free operation of this hood, the manufacturer suggests following these guidelines. Most problems associated with hoods are directly related to poor service and maintenance such as not replacing or cleaning filters.

Please record any maintenance or service performed on this fan in the documentation section located at the end of this manual.

General Maintenance

- Proper operation of the hood depends on how well the hood is maintained. All surfaces should be kept free of grease build-up for sanitation reasons and to reduce the risk of fire.
- Grease filters must always be installed and clean to reduce build-up of grease in the exhaust duct and to allow for proper exhaust airflow, refer to **Table 1 on page 42**. Maintain all belts, motors, and electrical connections on fans attached to the hood. Ensure MUA filters are kept clean and there are no leaks in MUA ductwork.

Daily Maintenance

1. Remove the grease baffle filters and clean in a dishwasher or soak sink daily.
2. Empty and clean grease drain and grease collection cups.
3. Carefully wipe away gritty substances clinging to stainless-steel surfaces to avoid scratching.
4. Dilute 1/2 cup of laundry detergent (e.g. Tide) with one (1) gallon of warm water.
5. Soak a clean cloth in the water detergent solution and wring out the excess water.
6. Wipe the hood surfaces moving in the direction of the grain and periodically rinsing cloth in detergent solution.
7. Using a different clean cloth soaked in clean warm water, wipe the hood surfaces to remove all traces of the detergent solution.
8. Wipe hood surfaces dry with a clean, dry cloth. Clean the hood temperature sensor in riser if equipped with one.
9. Reapply stainless-steel polish.

CAUTION

DO NOT use iron wool (Brillo or SOS pads), scrapers, or spatulas to clean hood!

DO NOT use the following substances on or around the hood:

1. Chlorine or chlorine based substances.
2. Acids (e.g. acetic, hydrochloric, sulfuric).
3. Chloride based substances (e.g. mercuric chloride, ferric chloride).

Vapors of the above substances can corrode stainless-steel!

Quarterly Maintenance

- Inspect the unit and duct for grease or air leaks and repair leaks where required.
- Clean ductwork attached to hood to prevent a mass accumulation of grease.

PSP/AC-PSP Perforated Screen Cleaning and Maintenance

If airflow diminishes or the perforated assembly appears clogged or dirty, follow these steps to clean the area. Refer to **Figure 37** for perforated supply details.

Note: You must wear protective gloves during this procedure.

1. Check supply fan. Clean as needed, repair if any damage is found.
2. Check filters. Clean and replace as needed.
3. Check volume dampers to ensure they are set correctly and have not been closed.
4. Remove perforated assemblies from PSP/AC-PSP.
 - Loosen the screws. The screws will have capture washers on the back. These are used to secure the center blank.
 - Remove the center blank. Grasp the perforated assembly and quickly pull, releasing the perforate assembly from the snap clips.
5. Clean perforated assemblies and wipe dry before reinstalling. **Do Not Use Chlorine, Bleach or Other Corrosive Cleaners.**
6. Carefully reinstall perforated assembly and secure with snap clip.
7. Place center blank back into location. Secure with capture washers and screws.

Figure 37 - Perforated Supply (AC/PSP Shown)

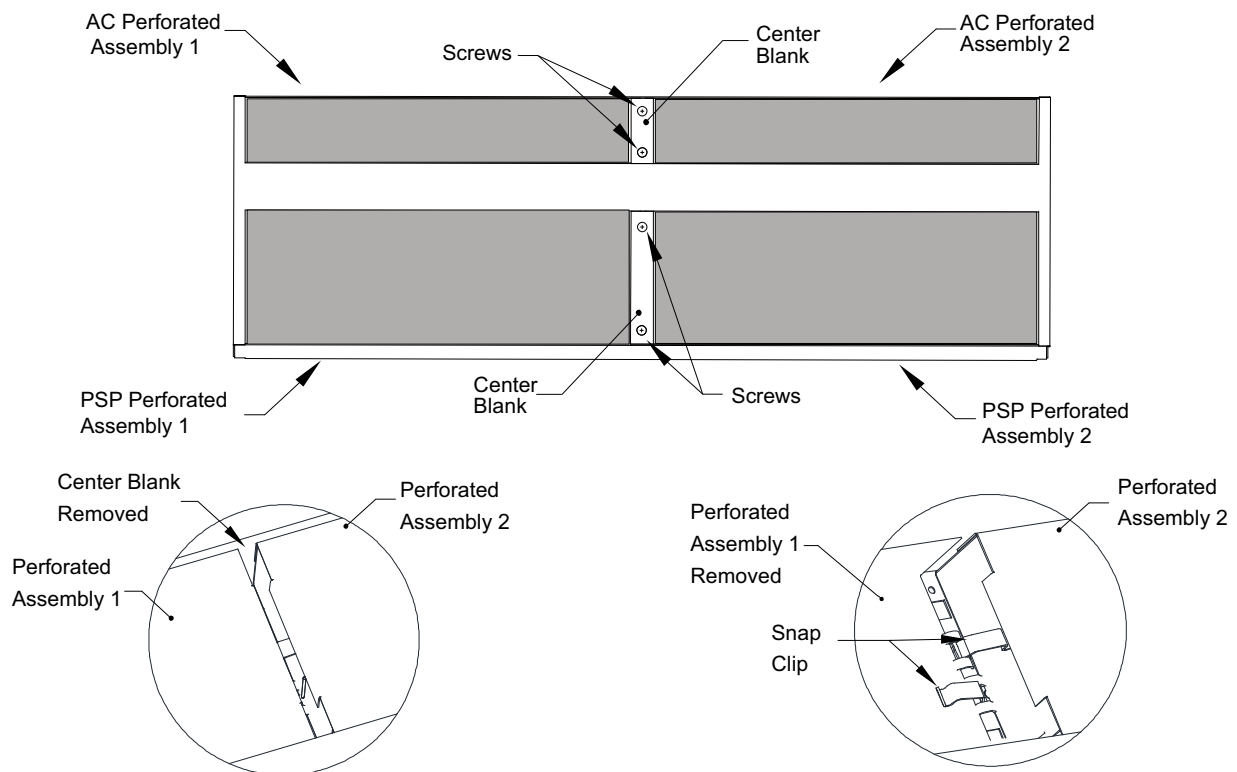

Table 1 - Recommended Cleaning Agents

Cleaning Method/Agent Type	Supplier	Product
Dishwasher Detergent	Ecolab Johnson Diversey	Solid Powder/Plus Suma DiverPak/Plus
Soak Method – Pot and Pan Detergent	Ecolab	Powder Detergent
Soak Method – Commercial Degreaser	Ecolab Johnson Diversey Zep	Decarbonizer MPX Soak Tank Solution Zep FS Pot Scrub
Heavy Duty Commercial Degreaser	Ecolab Johnson Diversey Zep	Grease Cutter Plus Suma Star Zep FS C.I.P Cleaner

Table 2 - Recommended Commercial Soak Tanks

Description	Supplier	Product	Contact
Heated Soak Tank	Hyginix	FOG Tank® (Use only Tiger Carbon Powder Remover®)	www.fogtank.com 858-566-6212 info@fogtank.com

