

Direct Expansion Coil Modules

Installation, Operation, and Maintenance Manual

Direct Expansion Coil Module



Direct Expansion Coil



RECEIVING AND INSPECTION

Upon receiving unit, check for any interior and exterior damage, and if found, report it immediately to the carrier. Also check that all accessory items are accounted for and are damage free.

WARNING!!

Installation of this module should only be performed by a qualified professional who has read and understands these instructions and is familiar with proper safety precautions. Improper installation poses serious risk of injury due to electric shock, and other potential hazards. Read this manual thoroughly before installing or servicing this equipment. **ALWAYS** disconnect power prior to working on module.

Save these instructions. This document is the property of the owner of this equipment and is required for future maintenance. Leave this document with the owner when installation or service is complete.

Table of Contents

WARRANTY	3
INSTALLATION	3
Mechanical	3
Site Preparation	3
Unit Inspection.....	3
Assembly	4
Roof Mount Installation with Blower Only Unit.....	5
Indoor Installation with Direct Fired Unit.....	5
Condensate Plumbing Connections	6
Refrigeration Plumbing Connections.....	7
Optional Moisture Eliminator Panel	11
Electrical.....	11
OPERATION.....	12
Special Tools Required.....	12
Start-up Procedure	12
Component Description.....	13
Troubleshooting.....	14
Troubleshooting Chart	14
MAINTENANCE	15
General Maintenance	15
Every 6 months	15
Yearly	15
Start-Up and Maintenance Documentation	16
Job Information	16
DX coil Information	16
Maintenance Record.....	16
Factory Service Department	16

WARRANTY

This equipment is warranted to be free from defects in materials and workmanship, under normal use and service, for a period of 2-years from date of shipment. This warranty shall not apply if:

1. The equipment is not installed by a qualified installer per the MANUFACTURER'S installation instructions shipped with the product.
2. The equipment is not installed in accordance with Federal, State, and Local codes and regulations.
3. The equipment is misused or neglected, or not maintained per the MANUFACTURER'S maintenance instructions.
4. The equipment is not operated within its published capacity.
5. The invoice is not paid within the terms of the sales agreement.

The MANUFACTURER shall not be liable for incidental and consequential losses and damages potentially attributable to malfunctioning equipment. Should any part of the equipment prove to be defective in material or workmanship within the 2-year warranty period, upon examination by the MANUFACTURER, such part will be repaired or replaced by MANUFACTURER at no charge. The BUYER shall pay all labor costs incurred in connection with such repair or replacement. Equipment shall not be returned without MANUFACTURER'S prior authorization and all returned equipment shall be shipped by the BUYER, freight prepaid to a destination determined by the MANUFACTURER.

INSTALLATION

It is imperative that this unit is installed and operated with the designed airflow and electrical supply in accordance with this manual. If there are any questions about any items, please call the service department at **1-866-784-6900** for warranty and technical support issues.

Mechanical

WARNING: DO NOT RAISE VENTILATOR BY THE INTAKE HOOD, FILTER TRACKS, OR PIPING – USE LIFTING LUGS PROVIDED OR A SLING.

Site Preparation

- Provide clearance around installation site to safely rig and lift equipment into its final position. Supports must adequately support equipment. Refer to manufacturer's estimated weights.
- Compressor Unit must be within 75 feet of air handler unit.
- Compressor Unit must not be near intake of air handler unit.
- Consider general service and installation space when locating unit.

Unit Inspection

- Inspect unit on delivery.
- Photograph any visible damage.
- Report any damage to the delivery carrier.
- Request a written inspection report from the Claims Inspector to substantiate claim.
- File a claim with the delivery carrier.
- Check unit's rating plate to verify proper electric and fuel type to meet job requirements.
- Compare unit received with description of product ordered.

Assembly

There are several items shipped loose with the DX coil modules. These items include sheet metal screws, nuts and bolts, and foam gaskets. It is important to know where the coil is to be installed. For direct fired heaters and electric coil modules, the DX coil module mounts to the end discharge side of the air handling unit. This keeps any potential leaking refrigerant from burning, avoiding the creation of toxic gases. Place caulk on the outside of any external screws used to prevent water leaks.

Upon unit arrival, follow the following procedure to assemble the DX coil.

For use with a direct fired or electric heater:

1. Attach the DX coil module to the discharge side of the air handler using the nuts, bolts and angle bracket washers included. Apply foam gasket to the air handler around the connection from module to module to ensure that there is a liquid-tight seal formed between the DX coil module and the air handling unit.
2. Attach the down discharge plenum to the end of the DX coil module using the supplied foam gasket, nuts, and bolts. Or, attach ductwork directly to the end of the unit using sheet metal screws following SMACNA guidelines.

For use without a direct fired or electric heater:

1. Attach the DX coil module to the intake side of the air handler using the nuts, bolts and angle washers included. Apply foam gasket to the air handler around the connection from module to module to ensure that there is a liquid-tight seal formed between the DX coil module and the air handling unit.
2. Complete installation of ductwork per SMACNA standard installation.

Figure 1 displays a typical DX installation assembly. The airflow distribution screen is located on the incoming air side of the coil. This screen evens out the airflow across the coil and allows for greater cooling efficacy. Removal of this screen may cause the coil to freeze or more serious damage.

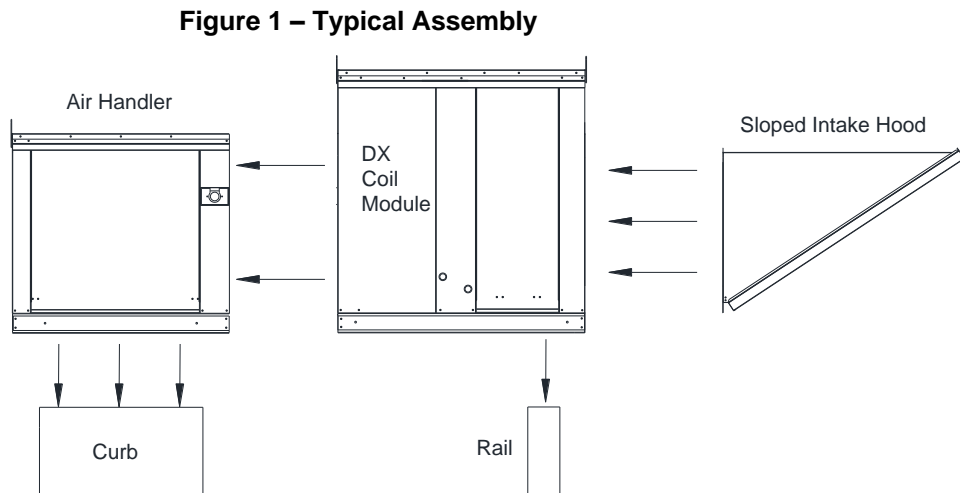

Roof Mount Installation with Blower Only Unit

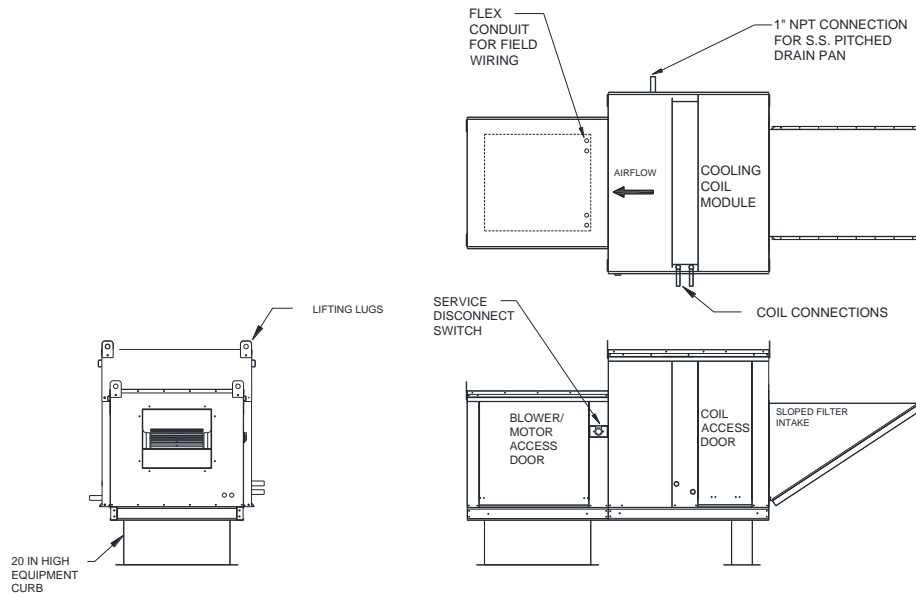

Indoor Installation with Direct Fired Unit

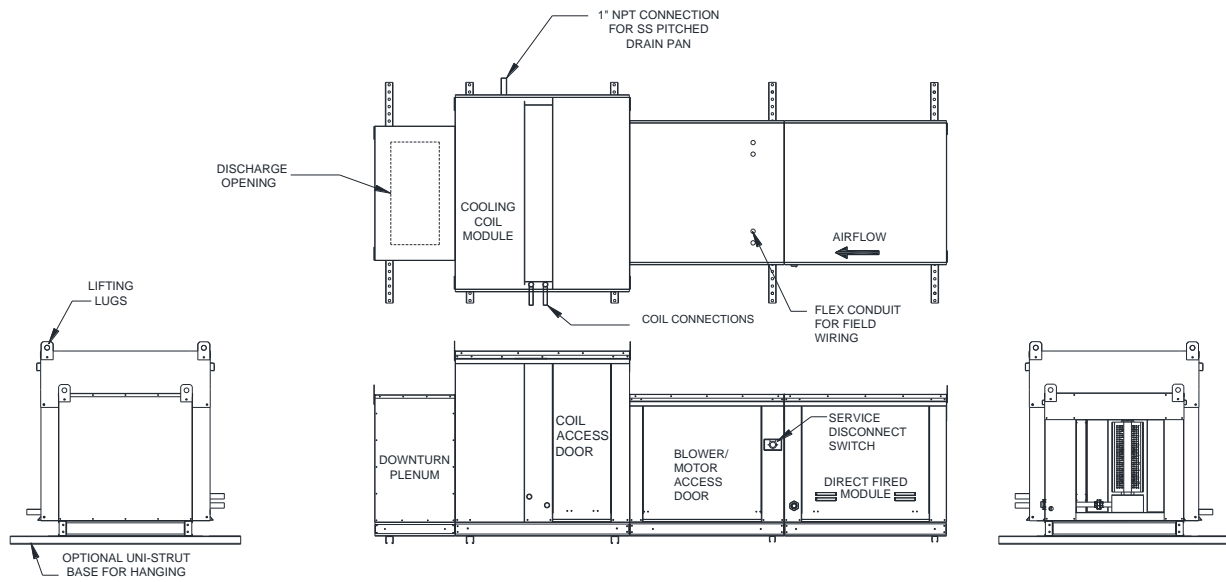

Condensate Plumbing Connections

There is one field plumbing connection required for proper DX coil operation. This is located by the drain pan, located under the DX coil. Depending on the size of the unit, the coil can generate 5 gallons of water per hour. It is imperative that the plumbing is sized accordingly. Also, it's recommended that all plumbing connections be sealed with Teflon tape or pipe dope.

Install Condensate Trap Assembly (**Figure 2**) to 1" threaded drain pan connection. Use low-profile couplings and 1" PVC piping to connect on-site drainage to the Condensate Trap Assembly. **DO NOT USE UNIONS.** The Condensate Trap Assembly is important for two reasons. First, it will allow drainage to be piped to the most convenient area. Second, it will keep air from being drawn into the system, impeding drainage. The top lids of the Condensate Trap Assembly should be removable to allow for cleaning of the trap.

Figure 2 – Typical Cooling Coil Drain Trap

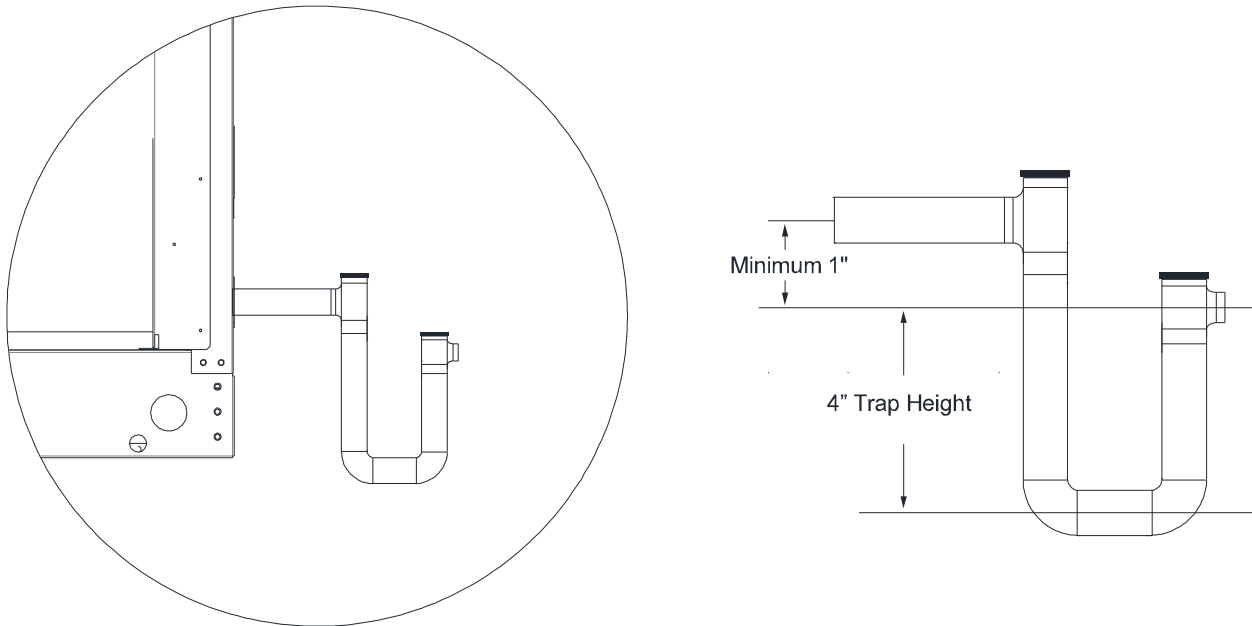

Refrigeration Plumbing Connections

WARNING: Technicians must be certified by an EPA-approved training and certification program to service any HVAC equipment, regardless of the refrigerant.

Several refrigeration connections need to be completed before the unit will function. Depending on the module you have selected, you may have only one suction line and one liquid line to connect (**Table 1**). Otherwise, two sets will need to be connected.

Common components installed are: a filter drier which will remove moisture from the refrigerant. The filter drier should be installed close to the condensing section. A sight glass should be installed close to the thermal expansion valve. This will help in diagnosing any problems with the air conditioning (A/C) setup. A solenoid is required when the liquid line exceeds 75 feet. This will prevent the buildup of liquid refrigerant from entering the compressor while the unit is off. If the suction line exceeds 75 feet, an accumulator will need to be installed to prevent any liquid refrigerant from entering the compressor. Depending on the distance between the condenser and the module, there may be other components installed in the lines. See **Figure 8** for typical AC components.

Table 1 – Plumbing Chart

Module	Connection size (suction/liquid)	Tonnage
DXM1-1	1.625/1.125	3
DXM1-2	1.625/1.125	5
DXM1-3	1.625/0.875	10
DXM1-4	1.625/0.875	12.5
DXM2-1	1.625/0.875	5
DXM2-2	1.625/0.875	10
DXM2-3	1.625/0.875	15
DXM2-4	1.625/0.875	20
DXM3-1	1.625/0.875	10
DXM3-2	1.625/0.875	15
DXM3-3	1.625/0.875	20
DXM3-4	1.625/1.125	25
DXM4-1	1.625/0.875	20
DXM4-2	1.625/0.875	25
DXM4-3	1.625/1.125	30
DXM4-4	2.125/1.125	40
DXM5-1	2.125/1.375	30
DXM5-2	2.125/1.375	40
DXM5-3	2.125/1.375	50
All Coils are 2 circuit coils, except for DXM1-1 and DXM1-2.		

Plumb Liquid and Suction Lines:

1. **Install the lines.** Keep the lines as short and as straight as possible. Also, keep the lines away from any sharp edge. The lines may vibrate some during normal use and this will keep the lines from breaching. **Figure 3** is a basic refrigeration diagram.
 - There are two different types of thermal expansion valves. Internally equalized valves will have 2 connections, one for liquid to the valve and one to the distributor of the coil. The externally equalized will have an additional fitting for the capped line from the coil.
 - If the coil has a hot gas bypass valve, install this with the instructions included in the kit.
2. **Braze the joints.** These joints will be under great pressure, so proper joint construction is imperative. All joints need to be made using Silver-Phosphorus or Copper-Phosphorus brazing filler, available from a local welding store. **DO NOT USE SOFT SOLDER**, this material does not produce a strong enough joint. It is also recommended to flow dry nitrogen through the lines to prevent joint oxidation while brazing.
 - Clean both mating surfaces with Emory cloth.
 - Fit both pieces together. If there are multiple joints within a short distance, clean and fit them together as well.
 - There are some parts in the lines that cannot be overheated. Parts like thermal expansion valves, solenoid valves, sight glasses, and accumulators cannot exceed **200° F**. Place a wet rag around these parts to cool them while you braze the joints. Avoid pointing the torch flame directly on these devices.
 - Heat using a TurboTorch® or equivalent torch using MAPP gas or Acetylene. Move the torch back and forth on the pipes. This will distribute the heat more evenly around the part. When the parts glow a dull red, pull the torch away slightly. Be careful not to overheat the pipe. Smaller pipes, if overheated, will begin to melt and burn.
 - Add brazing wire until the entire joint is covered. On larger diameters of pipe, you may need to move your torch around the diameter of the pipe.
 - If there are multiple joints to be made, move the torch and begin heating the next joint. This will save time and fuel.
 - Let the joints cool naturally. Cooling the joints with water could cause the joints to fail prematurely.

Pressure testing the lines:

1. Charge the lines with Dry Nitrogen to design operating PSI.
2. If the pressure holds for 15 minutes, proceed to **Vacuum the lines** instructions. If the pressure changes drastically, there is a leak. If the pressure drops slowly, there may be a leak.
 - Ultrasonically leak check all joints.
 - After all joints have been tested, bleed off the excess pressure and repair the joints. You will have trouble repairing the joints if there is pressure in the lines.
 - Start the pressure testing over.

Vacuum the lines

1. Verify valve cores installed on the compressor unit. If you cannot find the taps, check the owner's manual. Install a quick coupler access tee to the suction side of the condenser unit. Install a micron gauge on one port (**Figure 4**).
2. Install the pressure gauge manifold. Make sure both valves are closed on the manifold. The blue hose goes to the suction line. The red hose to the liquid line. The yellow hose line connects to a vacuum pump. Start the vacuum pump. To start vacuuming the system, open the blue hose side of the manifold. You should see the pressure start to drop.
3. Continue to vacuum the lines for 15 minutes, then stop. If the vacuum on the lines does not hold, there is a leak. Repeat step 2 to correct the problem. If the vacuum on the line holds, read the micron gauge. If the gauge does not read below 500, continue to vacuum the lines until the gauge does. You are now removing moisture from the lines. **This is very important!!!** The more moisture you remove now, the more efficiently the system will run. Close the valves to the pump and the system should be able to maintain a 1000 micron vacuum continuously.

Charging the system.

1. You will need a tank of refrigerant and a scale (**Figure 5**). The scale must be able to read ounces and have a max capacity of 50 Lbs. The refrigerant must come from an HVAC supplier. Make sure to read the condenser owner's manual for what type of refrigerant and how much you will need for your system. This step will be done while the condenser is off.
 - Attach the red line to the liquid line
 - Open the valves on the unit. This will release the holding charge into the circuit.
 - Attach the yellow hose to the tank of refrigerant. Open the valve on the tank. Invert the cylinder on the scale.
 - Open the blue valve on the manifold, slightly. This will allow charge to enter into the circuit.
 - Close the valve on the manifold after 80% (by weight) of the charge has been introduced.
 - **RECORD THE WEIGHT OF THE TANK.** This will tell you how much charge is left in the tank.
2. Trimming the refrigerant charge. Once the initial charge has been introduced into the system, allow the compressor to run for 15 minutes. This will balance the charge and help ensure accurate readings.
 - Locate the charging chart in the compressor owner's manual. Each chart will be different depending on the manufacturer of condenser unit. Most require a liquid pressure and temperature to be known.
 - Record the liquid line temperature and pressure. With the charging chart, plot the point where the system is operating. Note if it falls into the Add Charge or Reduce Charge.
 - Add charge. Slowly turn the Blue side of the pressure gauge manifold. This will allow the charge from the tank to enter the suction side of the compressor. After a sufficient amount of refrigerant has been added, close the blue side valve and allow the system to stabilize. Recheck temperature and pressure; re-plot the point on the chart, repeat the process if necessary.
 - Reduce charge. In the case of overfilling the circuitry, the excess refrigerant must be recovered into an approved cylinder.
 - Weigh the tank and record the changes.

Figure 3 – Basic Refrigerant Piping

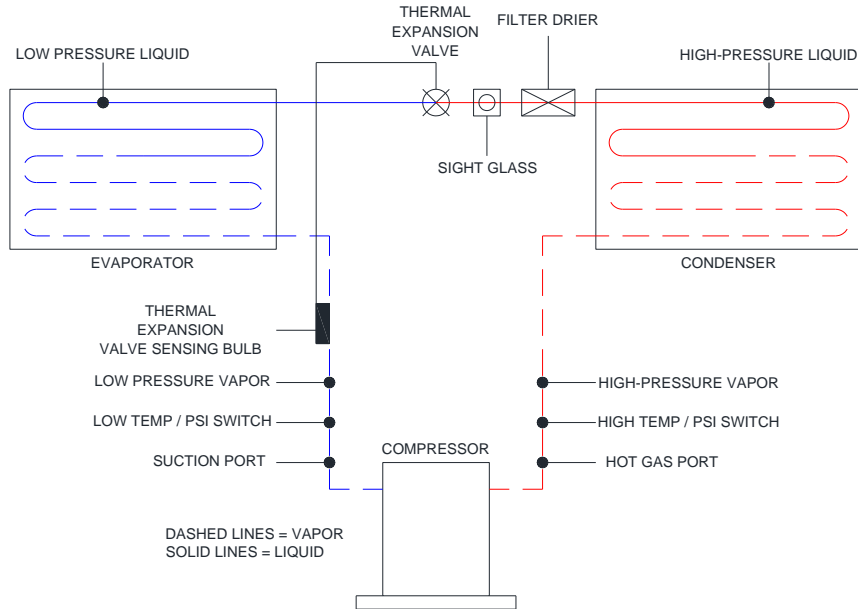

Figure 4 – Leak Test/Prep for Refrigerant Charge

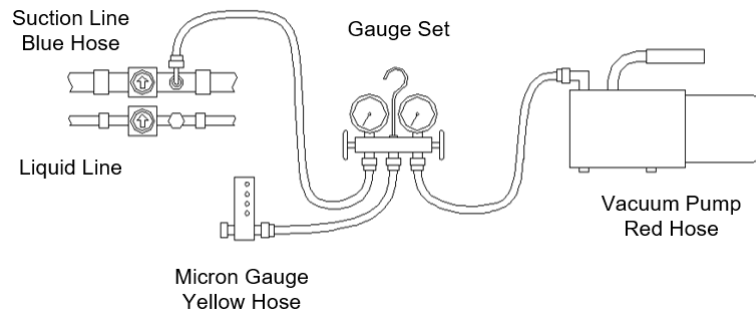
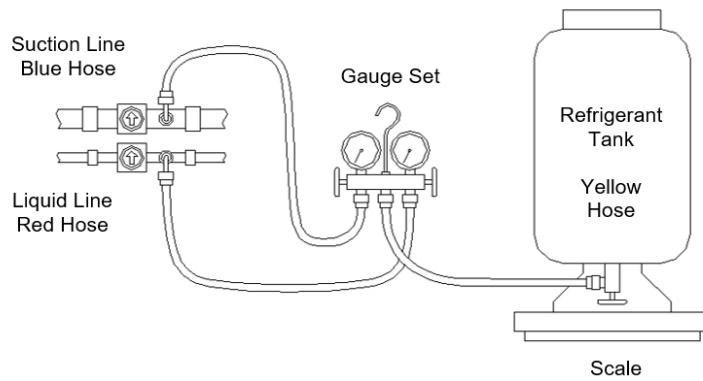

Figure 5 – Charging the System



Optional Moisture Eliminator Panel

If the unit is equipped with an optional moisture eliminator panel, the maximum face velocity of the coil may be increased to 650 FPM. Moisture eliminator panels require minimal maintenance. Visual inspection is recommended periodically. Scale or clogging will impair performance. If scale or clogging occurs, remove the panel and flush with steam or water. Flushing should not have sufficient force to dislodge the media from the panel. Scale removal may require a vinegar or detergent application followed by rinsing.

Electrical

Before connecting power to the module, read and understand the entire section of this document. As-built wiring diagrams are furnished with each module by the factory, and are attached either to the door of the unit or provided with a paperwork packet.

Electrical wiring (**Table 2**) and connections should be done in accordance with local ordinances and the National Electric Code, ANSI/NFPA70. Make sure the voltage and phase of the power supply and the wire amperage capacity is in accordance with the unit nameplate. For additional safety information refer to AMCA publication 410-96, *Recommended Safety Practices for Users and Installers of Industrial and Commercial Fans*.

1. Always **disconnect power** before working on or near this equipment. Lock and tag the disconnect switch or breaker to prevent accidental power-up.
2. Verify the power source is compatible with the requirements of your equipment. The air handler wiring schematic and the compressor documentation identifies the **proper phase and voltage** of the equipment.
3. Secure the power cable to prevent contact with sharp objects.
4. Do not kink power cable and never allow the cable to encounter oil, water, grease, hot surfaces or chemicals.
5. There are RC, Y1, and Y2 terminals for cooling in the electrical control package or heated make-up air. These terminals must be connected to the matching terminals in the condenser (**Figure 6** and **Figure 7**).
6. Before powering up the DX module and compressor unit, make sure that the interior of the unit is free of loose debris or shipping materials, and all refrigerant piping is complete.

WARNING!!
Disconnect power before installing or servicing module. High voltage electrical input is needed for this equipment. This work should be performed by a qualified electrician.

Table 2 – Copper Wire Ampacity

Wire Size AWG	Maximum Amps
14	20
12	25
10	30
8	40
6	55
4	70
3	85
2	95
1	110
0	125
00	145

Figure 6 – Terminals on Condensing Unit

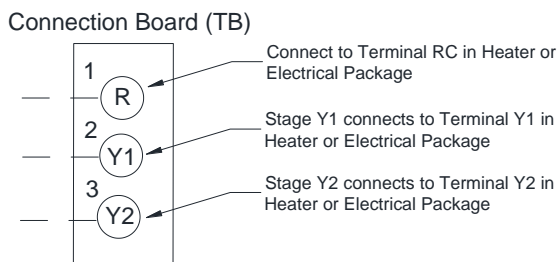
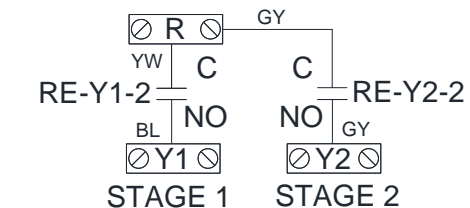

Figure 7 – Dry Contacts for Condensing Unit



Located on Pre-wire or Heated Make-Up Air Unit

OPERATION

Before starting up or operating the DX module, check all fasteners for tightness. Ensure that the coil is clean and that the interior of the module is free of loose debris. Also, check the drain pan for proper drainage. This will guarantee proper operation during the cooling season.

Special Tools Required

- AC Voltage Meter
- Amperage Meter
- Standard Hand Tools

Start-up Procedure

1. Remove the access door and check all electrical connections for tightness and continuity.
2. Inspect the airstream for obstructions.
3. Compare the supplied **voltage** with the unit's nameplate voltage. If this does not match, correct the problem.
4. Set the thermostat to a set-point cooler than the entering air temperature for start-up purposes. The cooling circuit will be energized when the entering air temperature is hotter than the thermostat set-point.
5. Install the access door and apply power to the unit. If the entering air temperature is hotter than the thermostat set-point, the cooling circuit will be energized the first stage of the compressor should turn on.
6. Locate the sight glass and observe the refrigerant flow for a few minutes. This run time will allow the unit to stabilize. If the line has is foaming, a large number of bubbles, you may need to add charge to your unit.
7. Adjust the thermostat so that the second stage turns on at a difference of 10°F (typical) is required. Repeat step 6.
8. Set the thermostat back to the desired cooling temperature (typically about 75°F-85°F). Remember, the cooling circuit will only be energized when the entering air temperature is higher than the set-points.

Component Description

Figure 8 - Typical Installation of an AC system

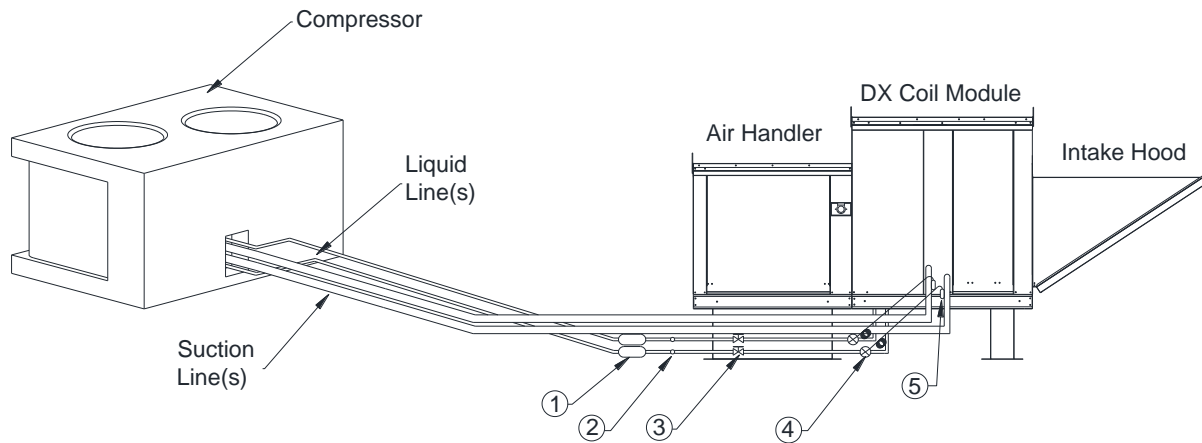

The following table lists common components and their function inside the AC system.

Component Number	Component	Description of Operation
1	Filter Drier	Removes moisture and small particulate from the refrigerant lines.
2	Sight Glass with Moisture Indicator (optional)	Allows for viewing of refrigerant flow and moisture content.
3	Solenoid Valve (required for liquid line lengths over 75 Feet)	Valve, wired in parallel to the signal lines, blocks the flow of liquid refrigerant back into the compressor during reset.
4	Thermal Expansion Valve	Controls the amount of liquid refrigerant flowing into the coil, with the use of a capillary bulb.
5	Thermal Expansion Valve Sensing Bulb	Senses the suction line temperature and adjusts refrigerant flow accordingly.

Troubleshooting

The following table lists causes and corrective actions for possible problems with DX coil modules. Review this list before consulting manufacturer.

Troubleshooting Chart

Problem	Potential Cause	Corrective Action
Insufficient Cooling	Frozen coil	Reduce refrigerant charge.
		Check for proper airflow across coil.
	Charge is low	Add refrigerant charge.
	Excessive airflow	Slow blower RPM down.
Insufficient Airflow	Contaminated refrigerant	Replace refrigerant.
	Coil sized too small *	Increase airflow across coil. Replace module with larger coil.
	Underestimation of static pressure	Reduce blower rpm.
Excessive Airflow	Coil sized too large *	Change motor HP.
		Slow blower RPM down.
Water in ductwork	Drain pan full	Check drain pan for obstructions.
	Ductwork is not insulated	Check drain pan plumbing for clogs.
		Insulate ductwork to reduce condensation.

* Air velocity should be maintained between 200 and 550 FT per Minute through the coil.

MAINTENANCE

To guarantee trouble-free operation of this DX coil module, the manufacturer suggests following these guidelines. Most problems associated with unit failures are directly related to poor service and maintenance.

Please record any maintenance or service performed on this equipment in the documentation section located at the end of this manual.

WARNING: DO NOT ATTEMPT MAINTENANCE ON THE DX MODULE OR COMPRESSOR UNIT UNTIL THE ELECTRICAL SUPPLY HAS BEEN COMPLETELY DISCONNECTED

General Maintenance

1. Inlet and approaches to DX module and compressor unit should be kept clean and free from any obstruction.
2. All fasteners should be checked for tightness each time maintenance checks are performed before restarting unit.
3. DX coil modules require little attention when moving clean air. Occasionally, dust may accumulate on the coil causing low airflow or reduced cooling. The DX coil should be inspected and cleaned every 6 months during the cooling season.

Every 6 months

1. Check and clean the drain pan and drain.
2. Clean the DX coil from the entering airside. This will keep any grit or particulate from lodging itself deeper into the coil. The air deflection screen must be removed before cleaning.

Yearly

1. Check the coil for damage. If there is evidence of a leak, seek professional help.
2. Check the moisture indicator inside the sight glass. If the indicator reads wet, call a professional for more information and repair.

Start-Up and Maintenance Documentation

START-UP AND MEASUREMENTS SHOULD BE PERFORMED AFTER THE SYSTEM HAS BEEN AIR BALANCED (Warranty will be void without completion of this form)

Job Information

Job Name	
Address	
City	
State	
Zip	
Phone Number	
Fax Number	
Contact	
Purchase Date	

Service Company	
Address	
City	
State	
Zip	
Phone Number	
Fax Number	
Contact	
Start-Up Date	

DX coil Information

Refer to the start-up procedure in this manual to complete this section.

Name Plate and Unit Information	
Model Number	
Serial Number	
Volts	
Hertz	
Phase	
Tonnage	

Field Measured Information		
Refrigerant type		
Refrigerant volume		Lbs.
Airflow Direction	Correct	
	Incorrect	
Refrigerant Line Pressures	Liquid (1/ 2)	/
	Suction(1/ 2)	/

Maintenance Record

Date	Service Performed

Factory Service Department

Phone: 1-866-784-6900
Fax: 1-919-554-9374